

TECHNICAL MANUAL

**OPERATOR'S, ORGANIZATIONAL
DIRECT SUPPORT
AND
GENERAL SUPPORT MAINTENANCE MANUAL
VOLTMETER, DIGITAL AN/GSM-64C
(NSN 6625-01-124-0834) (EIC: KNK)**

DISTRIBUTION STATEMENT A-Approved for public release; distribution is unlimited.

HEADQUARTERS, DEPARTMENT OF THE ARMY

11 MARCH 1983



5

SAFETY STEPS TO FOLLOW IF SOMEONE IS THE VICTIM OF ELECTRICAL SHOCK

1

DO NOT TRY TO PULL OR GRAB THE INDIVIDUAL

2

IF POSSIBLE , TURN OFF THE ELECTRICAL POWER

3

IF YOU CANNOT TURN OFF THE ELECTRICAL POWER, PULL, PUSH, OR LIFT THE PERSON TO SAFETY USING A WOODEN POLE OR A ROPE OR SOME OTHER INSULATING MATERIAL

4

SEND FOR HELP AS SOON AS POSSIBLE

5

AFTER THE INJURED PERSON IS FREE OF CONTACT WITH THE SOURCE OF ELECTRICAL SHOCK, MOVE THE PERSON A SHORT DISTANCE AWAY AND IMMEDIATELY START ARTIFICIAL RESUSCITATION

WARNING

DANGEROUS VOLTAGES EXIST IN THIS EQUIPMENT

100/120/220/240 Vac mains connections are used within the voltmeter. Be careful when working on equipment if covers are removed and power cable is plugged into ac power outlet.

WARNING

When making off-ground (guarded) measurements, the internal guard shield may be at a dangerous potential to ± 300 volts with respect to case ground. Exercise proper personnel hazard precautions when connecting and disconnecting test leads.

WARNING

When measuring voltages above 30 volts, a shock hazard may exist. If necessary, turn off power to all associated equipment when connecting and disconnecting test leads.

WARNING

To be usable for cleaning, the compressed air source must limit the nozzle pressure to no more than 29 pounds per square inch gauge (PSIG). Goggles must be worn at all times while cleaning with compressed air.

WARNING

Isopropyl Alcohol is flammable and toxic to eyes, skin, and respiratory tract. Wear protective gloves and goggle/face shield. Avoid repeated or prolonged contact. Use only in well-ventilated areas (or use approved respirator as determined by local safety/industrial hygiene personnel). Keep away from open flames, sparks or other sources of ignition.

CHANGE)
)
No. 1)

Headquarters
Department of the Army
Washington, D.C., 13 January 2006

**OPERATOR'S, ORGANIZATIONAL, DIRECT SUPPORT AND
GENERAL SUPPORT MAINTENANCE MANUAL**

FOR
VOLTMETER, DIGITAL AN/GSM-64C
(NSN 6625-01-124-0834)
(EIC: KNK)

HAZARDOUS MATERIAL INFORMATION – This document has been reviewed for the presence of solvents containing hazardous materials as defined by the EPCRA 302 and 313 lists by the AMCOM G-4 (Logistics) Environmental Division. As of the base document, dated 11 March 1983, all references to solvents containing hazardous materials have been removed from this document by substitution with non-hazardous or less hazardous materials where possible.

OZONE DEPLETING CHEMICAL INFORMATION – This document has been reviewed for the presence of Class I ozone depleting chemicals by AMCOM G-4 (Logistics) Environmental Division. As of the base document, dated 11 March 1983, all references to Class I ozone depleting chemicals have been removed from this document by substitution with chemicals that do not cause atmospheric ozone depletion.

DISTRIBUTION STATEMENT A- Approved for public release; distribution is unlimited.

TM 11-6625-444-14-2, dated 11 March 1983, is changed as follows:

1. Remove old pages and insert new pages as indicated below. New or changed material is indicated by a vertical bar in the outer margin of the page. Illustration changes are indicated by a pointing hand. New or changed part numbers are indicated by an asterisk (*). Completely revised sections or chapters are indicated by a vertical bar next to the title only.

Remove Pages

a/ (b blank)
A/(B blank)
i and ii
1-1, 1-2
4-1 through 4-4
6-23 through 6-26
A-1/(A-2 blank)
Cover

Insert Pages

a/ (b blank)
A/(B blank)
i and ii
1-1, 1-2
4-1 through 4-4
6-23 through 6-26
A-1/(A-2 blank)
Cover

2. File this change sheet in front of the publication for reference purposes.

By Order of the Secretary of the Army:

Official:



SANDRA R. RILEY

*Administrative Assistant to the
Secretary of the Army*

0531903

PETER J. SCHOOMAKER
*General, United States Army
Chief of Staff*

DISTRIBUTION:

To be distributed in accordance with the initial distribution number (IDN) 360690,
requirements for TM 11-6625-444-14-2.

INSERT LATEST CHANGED PAGES. DESTROY SUPERSEDED PAGES.

LIST OF EFFECTIVE PAGES

NOTE

ON CHANGED PAGES, THE PORTION OF THE TEXT AFFECTED BY THE LATEST CHANGE IS INDICATED BY A VERTICAL LINE OR OTHER CHANGE SYMBOL IN THE OUTER MARGIN OF THE PAGE.

Date of issue for original and changed pages are:

Original 0 11 March 1983
 Change 1 13 January 2006

Total number of pages in this publication is 158 consisting of the following:

Page No.	*Change No.
Cover	1
A/(B blank)	1
i	1
ii through vi	0
1-1	1
1-2 through 1-4	0
2-1 through 2-3	0
3-1 through 3-17	0
4-1	1
4-2 and 4-3	0
4-4.....	1
4-5 and 4-6	0
5-1 through 5-13	0
6-1 through 6-23	0
6-24.....	1
6-25.....	0
6-26.....	1
6-27 through 6-60	0
A-1/(A-2 blank)	1
B-1 through B-4	0
B-5/(B-6 blank)	0
FO-1.....	0
FO-2.....	0
FO-3.....	0
FO-4.....	0
FO-5.....	0
FO-6.....	0
FO-7.....	0
FO-8.....	0
FO-9.....	0
FO-10.....	0
FO-11.....	0
FO-12.....	0
FO-13.....	0
FO-14.....	0

* Zero in this column indicates an original page.

Technical Manual)
)
No. 11-6625-444-14-2)

Headquarters
Department of the Army
Washington, D.C., 11 March 1983

**OPERATOR’S, ORGANIZATIONAL, DIRECT SUPPORT
GENERAL SUPPORT MAINTENANCE MANUAL
FOR
VOLTMETER, DIGITAL AN/GSM-64C
(NSN 6625-01-124-0834)(EIC:KNK)**

REPORTING ERRORS AND RECOMMENDING IMPROVEMENTS

You can improve this manual. If you find any mistakes or if you know of a way to improve the procedures, please let us know. Mail your letter or DA Form 2028 (Recommended Changes to Publications and Blank Forms) directly to: Commander, U.S. Army Aviation and Missile Command, AMSAM-MMC-MA-NP, Redstone Arsenal, AL 35898-5000. A reply will be furnished to you. You may also provide DA Form 2028 information to AMCOM via email, fax or the World Wide Web. Our fax number is DSN 788-6546 or Commercial 256-842-6546. Our email address is: 2028@redstone.army.mil. Instruction for sending an electronic 2028 may be found at the back of this manual immediately preceding the hardcopy 2028. For the World Wide Web use: <https://amcom2028.redstone.army.mil>.

HAZARDOUS MATERIAL INFORMATION

This document has been reviewed for the presence of solvents containing hazardous materials as defined by the EPCRA 302 and 313 lists by the AMCOM G-4 (Logistics) Environmental Division. As of the base document, dated 11 March 1983, all references to solvents containing hazardous materials have been removed from this document by substitution with non-hazardous or less hazardous materials where possible.

OZONE DEPLETING CHEMICAL INFORMATION

This document has been reviewed for the presence of Class I ozone depleting chemicals by the AMCOM G-4 (Logistics) Environmental Division. As of the base document through, dated 11 March 1983, all references to Class I ozone depleting chemicals have been removed from this document by substitution with chemicals that do not cause atmospheric ozone depletion.

DISTRIBUTION STATEMENT A-Approved for public release; distribution is unlimited.

TABLE OF CONTENTS

CHAPTER 1.	INTRODUCTION	Paragraph	Page
Section I.	General		
	Scope	1-1	1-1
	Indexes of publications	1-2	1-1
	Forms and records	1-3	1-1
	Reporting equipment improvement recommendations (EIR)	1-4	1-1
Section II.	Description and data		
	Purpose and use	1-5	1-2
	Description	1-6	1-2
	Tabulated data	1-7	1-2
	Items comprising an operable equipment	1-8	1-4
CHAPTER 2.	INSTALLATION		
Section I.	Service upon receipt		
	Unpacking	2-1	2-1
	Checking unpacked equipment	2-2	2-1
Section II.	installation instructions		
	Portable use	2-3	2-1
	Rack installation	2-4	2-3
CHAPTER 3.	OPERATING INSTRUCTIONS		
Section I.	Controls and instruments		
	General	3-1	3-1
	Damage from improper settings	3-2	3-1
	Guarded measurements	3-3	3-7
Section II.	Operation under normal conditions		
	General	3-4	3-10
	Preliminary starting procedure	3-5	3-10
	Dc voltage measurement	3-6	3-10
	DC/DC ratio measurement	3-7	3-11
	Ac voltage measurement	3-8	3-12
	14c + Dc voltage measurement	3-9	3-13
	Remote programming	3-10	3-15
	BCD output	3-11	3-16
	Stand by operation	3-12	3-16
	Procedures for shutdown	3-13	3-16

TABLE OF CONTENTS (Cont)

CHAPTER 3.	OPERATING INSTRUCTIONS (Cont)	Paragraph	Page
Section III.	Preparation for movement		
	General	3-14	3-17
	Bench/shelf movement	3-15	3-17
	Rack removal (optional rack installation)	3-16	3-17
CHAPTER 4.	OPERATOR AND ORGANIZATIONAL MAINTENANCE		
Section I.	Tools and equipment		
	General	4-1	4-1
	Materials required	4-2	4-1
Section II.	Lubrication		
	Lubrication	4-3	4-1
Section III.	Preventive maintenance checks		
	General	4-4	4-1
	Checks and services	4-5	4-2
Section IV.	Troubleshooting		
	General	4-6	4-5
	Procedure	4-7	4-5
Section V.	Maintenance of voltmeter		
	General	4-8	4-5
	Removal/replacement	4-9	4-5
	Cleaning	4-10	4-6
	Functional testing	4-11	4-6
CHAPTER 5.	FUNCTIONING OF EQUIPMENT		
Section I.	Block diagram analysis		
	Introduction	5-1	5-1
	Dc measurement mode	5-2	5-1
	Ac measurement mode	5-3	5-1
	Dc ratio mode	5-4	5-2
	Analog to digital (A/D) converter	5-5	5-3
	Auto ranging	5-6	5-4
Section II.	Logic circuit description		
	Introduction	5-7	5-5
	Range logic tables	5-8	5-5
	Autorange logic (A1 Assembly)	5-9	5-7

TABLE OF CONTENTS (Cont)

CHAPTER 5.	FUNCTIONING OF EQUIPMENT (Cont)	Paragraph	Page
Section II.	Logic circuit description (cont)		
	Up range detector, minus voltage	5-10	5-8
	Up range detector, plus voltage	5-11	5-8
	Down range detector, minus voltage	5-12	5-8
	Down range detector, plus voltage	5-13	5-8
	Autorange logic (A2 Assembly)	5-14	5-8
	Remote autorange	5-15	5-9
	Ratio autoranging (A1 Assembly)	5-16	5-10
	Ratio up range detector, plus input signal	5-17	5-10
	Ratio up range detector, minus input signal . . .	5-18	5-10
	Ratio down range detector, plus input signal . .	5-19	5-10
	Ratio down range detector, minus input signal .	5-20	5-11
	Function logic tables	5-21	5-11
	Timing waveforms	5-22	5-13
CHAPTER 6.	DIRECT SUPPORT AND GENERAL SUPPORT MAINTENANCE		
Section I.	General		
	Introduction	6-1	6-1
	Tools and test equipment	6-2	6-1
	Schematic diagrams	6-3	6-1
Section II.	Tools and test equipment		
	Tools and test equipment required	6-4	6-4
Section III.	Troubleshooting		
	General	6-5	6-4
	Fault isolation	6-6	6-4
	Power supply checks	6-7	6-5
Section V.	Maintenance of the voltmeter		
	General	6-8	6-21
	Disassembly	6-9	6-21
	Cleaning instructions	6-10	6-24
	Repair and replacement	6-11	6-24
	Assembly	6-12	6-26
Section V.	Performance assurance tests		
	General	6-13	6-29
	Performance testing	6-14	6-29

TABLE OF CONTENTS (Cont)

CHAPTER 6.	DIRECT SUPPORT AND GENERAL SUPPORT MAINTENANCE	Paragraph	Page
Section VI.	Minimum specifications of equipment required		
	General	6-15	6-34
	Dc volts accuracy adjustments	6-16	6-36
	Dc ratio accuracy adjustments	6-17	6-39
	Dc volts autoranging adjustments	6-18	6-45
	Dc/dc ratio autoranging adjustments	6-19	6-47
	Ac volts accuracy adjustments	6-20	6-50
	Final procedure	6-21	6-59
APPENDIX A.	REFERENCES		A-1
APPENDIX B.	MAINTENANCE ALLOCATION		
Section I.	Introduction		B-1
Section II.	Maintenance allocation chart for Voltmeter AN/GSM-64C		B-3
Section III.	Tool and test equipment requirements for Digital Voltmeter, AN/GSM-64C		B-5

LIST OF ILLUSTRATIONS

Figure	Title	Page
1-1	Digital Voltmeter AN/GSM-64C	1-0
1-2	Outline Drawing, Portable Configuration	1-5
1-3	Outline Drawing, Rack Mount Configuration	1-6
2-1	An/GSM-64C Packing Diagram	2-2
2-2	Voltage Selection and Fused Receptacle (Rear Panel)	2-3
2-3	Equipment Connections	2-4
2-4	Rack Mount installation	2-5
3-1	Front Panel Controls and Instruments	3-2
3-2	Rear Panel Controls and instruments	3-6
3-3	Common Mode Signal Configuration	3-8
3-4	Guarded Signal Configuration	3-9
3-5	Average, Rms, and Peak Voltage Relationship of a Sine Wave	3-13
3-6	Effect of Dc Bias on the True Rms Voltage of a Square Wave	3-14
4-1	Knob Removal and Replacement	4-6
5-1	Range Selection Diagram	5-6
5-2	Function Selection Diagram	5-12
5-3	Timing Waveforms	5-14
6-1	Location of Test Points	6-2

LIST OF ILLUSTRATIONS (Cont)

Figure	Title	Page
6-2	Location of Adjustments	6-3
6-3	Location of Connectors	6-3
6-4	Troubleshooting Flow Chart, Dc Voltage	6-6
6-5	Troubleshooting Flow Chart, Ac Voltage	6-11
6-6	Troubleshooting Flow Chart, Dc/Dc Ratio	6-13
6-7	Troubleshooting Flow Chart, Auto Ranging	6-15
6-8	PCB, Digital Circuit Board....	6-19
6-9	PCB, Analog Circuit Board....	6-20
6-10	Digital Voltmeter AN/GSM-64C, Exploded View.	6-22
6-11	Rms Converter (A7) Signal Input Connections	6-23
6-12	Digital Voltmeter AN/GSM-64C, Front Panel Assembly	6-25
6-13	Digital Voltmeter AN/GSM-64C, Bottom Cover Explosion	6-27
6-14	Digital Voltmeter AN/GSM-64C, Rear Panel Assembly	6-28
6-15	DcVoltage Accuracy Checks	6-29
6-16	Dc/dc Ratio Accuracy Checks	6-31
6-17	AcVoltage Accuracy Checks.	6-33
6-18	Dc Volts Calibration, Equipment Connections	6-36
6-19	Location of Adjustments, Analog and Ratio Boards	6-37
6-20	DC Ratio Calibration, Equipment Connections	6-40
6-21	DC Ratio Calibration, Equipment Connections	6-42
6-22	Location of Test Points	6-43
6-23	DC Ratio Auto Range Detector Calibration	6-44
6-24	Location of Adjustments and Test Points, Autoranging	6-45
6-25	DC Voltage Autoranging, Equipment Connections	6-46
6-26	DC/DC Ratio Autoranging, Equipment Connections	6-49
6-27	Location of Adjustments, True Rms Board	6-50
6-28	RMS Converter Adjustment, Equipment Connections	6-51
6-29	Crest Factor Adjustment, Equipment Connections	6-56
6-30	DC Volts Accuracy, Equipment Connections.	6-58
6-31	AC Volts Accuracy Check, Equipment Connections	6-60
FO-1	Voltmeter Block Diagram	All fold-out illustrations are located in back of manual.
FO-2	Power Supply (A1, A2) Schematic Diagram	
FO-3	Dc Volts Attenuator/Analog Switching (A1) Schematic Diagram	
FO-4	A/D Converter Schematic Diagram	
FO-5	Auto Range Up/Down Detector (A1) Schematic Diagram	
FO-6	Relay Switching Circuits (A1) Schematic Diagram	
FO-7	Function Select Logic (A2) Schematic Diagram	
FO-8	Manual/Auto/Remote Range Circuits (A2) Schematic Diagram	
FO-9	Counters and Display Circuits (A2, A3) Schematic Diagram	
FO-10	Parallel BCD Output (A2) Schematic Diagram	
FO-11	Range Encoder/DP Encoder Circuits (A2) Schematic Diagram	
FO-12	Rms Converter Preamplifier and Scaling (A7) Schematic Diagram	
FO-13	True Rms Converter (A7) Schematic Diagram	
FO-14	Dc Ratio Amplifier (A9) Schematic Diagram	

LIST OF TABLES

Table No.	Title	Page
1-1	Dc Voltage Ranges	1-2
1-2	Ac Voltage Ranges	1-3
1-3	Ac Voltage Accuracy	1-4
3-1	Front Panel Controls and Instruments	3-3
3-2	Rear Panel Controls and Instruments	3-7
3-3	Ratio initialization Voltages	3-12
3-4	Remote Program Connector, A2J16	3-15
3-5	BCD Output Logic	3-16
4-1	Material Required	4-1
4-2	Operator's Preventive Maintenance Checks and Services	4-2
4-3	Organizational Preventive Maintenance Checks and Services	4-3
5-1	Ac Attenuation	5-2
5-2	Ratio Polarity	5-3
5-3	Ratio Ranging	5-4
5-4	Manual Range Selection Logic, A2-U57	5-5
5-5	Range Selection Logic, A2-U67	5-7
5-6	Range Selection Logic, A2-U250.	5-7
5-7	Autorange Logic, A2-U52	5-9
5-8	Function Select Logic, A2-U8	5-11
5-9	Function Select Logic, A2-U251	5-13
6-1	Required Test Equipment	6-4
6-2	Power Supply voltage Measurement	6-5
6-3	Voltmeter Dc Voltage Accuracy Checks	6-30
6-4	Voltmeter Ac Voltage Accuracy Checks	6-31
6-5	Voltmeter Dc/dc Ratio Autoranging Checks	6-32
6-6	Voltmeter Ac Voltage Accuracy Checks	6-33
6-7	Minimum Specifications of Equipment Required	6-34
6-8	Accessories Required	6-35
6-9	Rms Converter Dc Range Checks.	6-58
6-10	Rms Converter Ac Range Checks.	6-59

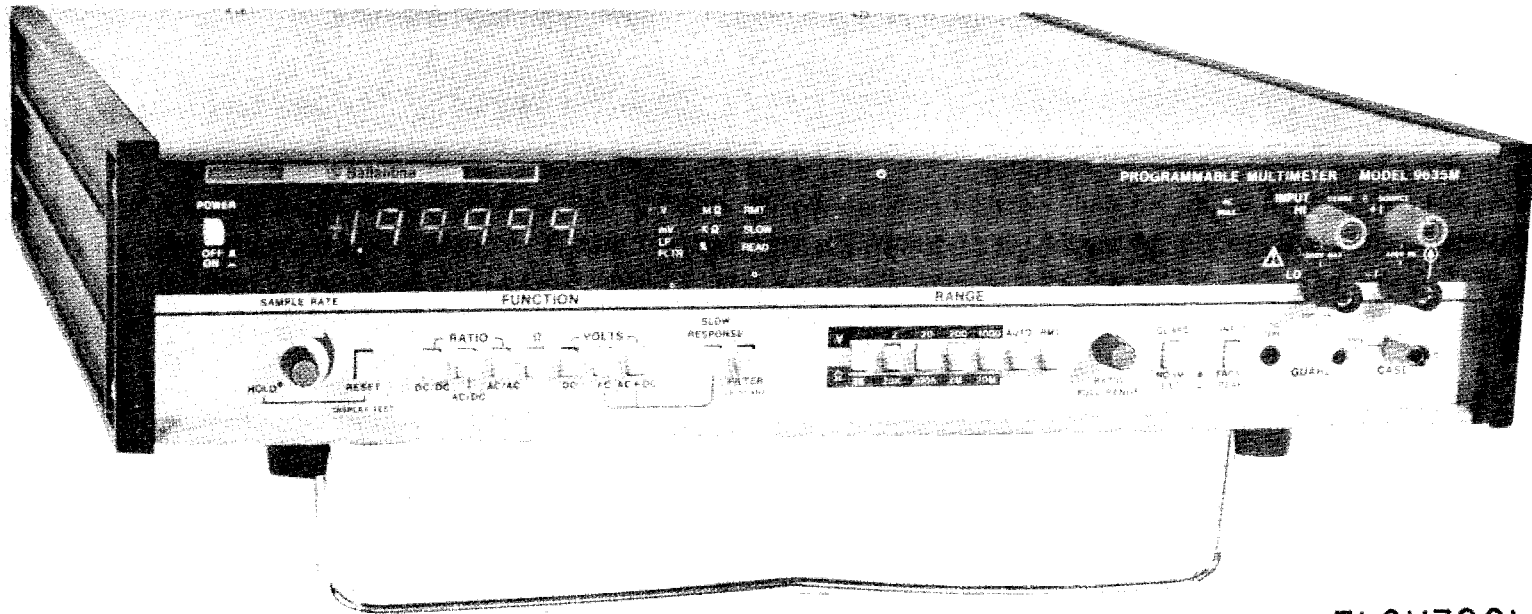

EL6UZ001

Figure 1-1. Digital Voltmeter AN/GSM-64C

CHAPTER 1

INTRODUCTION

Section I. GENERAL

1-1. Scope

This manual describes Voltmeter, Digital AN/GSM-64C (Voltmeter) and provides instructions for operation, organizational, direct support, and general support (GS) maintenance. Instructions are provided for the operator and organizational technician for installation, operation and preventive maintenance. Circuit functioning is included for general support maintenance together with instructions appropriate to these categories of maintenance for troubleshooting, testing, and repairing the equipment and replacing maintenance parts.

1-2. Indexes of Publications

a. DA Pam 25-30. Refer to the latest issue of DA Pam 25-30 to determine whether there are new editions, changes or additional publications pertaining to the equipment.

b. DA Pam 25-30. Refer to DA Pam 25-30 to determine whether there are modification work orders (MWO'S) pertaining to the equipment.

1-3. Forms and Records

a. Reports of Maintenance and Unsatisfactory Equipment. Maintenance forms, records and

reports which are to be used by maintenance personnel at all levels are listed in and prescribed by DA Pam 750-8.

b. Report of Packaging and Handling Deficiency. Fill out and forward DD Form 6 (Packaging Improvement Report) as prescribed in AR 735-11-2/NAVSUPINST 4030.29/AFR 71-13/MCO P4030.29A, and DLAR 4145.8.

c. Discrepancy in Shipment Report (DISREP) (SF 361). Fill out and forward Discrepancy in Shipment Report (DISREP) (SF 361) as prescribed in DA Pam 25-30/NAVSUPINST 4610.33B/AFR 75-18 - /MCO P4610.19C and DLAR4500.15.

d. Destruction of Army Electronics Materiel. Demolition and destruction of electronic equipment will be under the direction of the commander and in accordance with TM 750-244-2.

1-4. Reporting Equipment Improvement Recommendations (EIR).

EIR's will be prepared using Standard Form 368, Quality Deficiency Report. Instructions for preparing EIR's are provided in DA Pam 750-8 the army Maintenance Management System Users Manual. Mail EIRs directly to US Army Aviation and Missile Command, ATTN: AMSAM-MMC-MA-NM, Redstone Arsenal, AL 35898-5000. A reply will furnish direct to you.

Section II. DESCRIPTION AND DATA

1-5. Purpose and Use

a. The voltmeter is a precision 5½ digit instrument capable of accurately measuring dc voltages from ± 0.0001 V to ± 1000.00 V and true rms ac voltages from 0.0001 V to 1000.00 V. It also permits dc voltage ratio measurements from ± 0.001% to ± 100.000% by comparing the input voltage to an external reference voltage.

b. Special features include a variable sample rate, automatic ranging, switch selectable rear input terminals, remote control capability and parallel BCD output for long term monitoring.

c. Field installable options include provisions for measuring resistance, ac/dc ratio and ac/ac ratio.

1-6. Description

a. The voltmeter is a completely solid state instrument incorporating push button selection (as

well as auto-ranging) of four dc voltage ranges, four ac true rms voltage ranges and four dc voltage ratio ranges. Readings are indicated on a large 5½ digit display easily viewed from distances up to 20 feet. With the exception of parallel rear input connectors and external reference terminals, all of the controls, indicators and connectors are conveniently located on the front panel.

b. The voltmeter is comprised of four major printed circuit assemblies; an analog circuit board, main digital board, rms converter board, and a dc ratio board. It is packaged in a low profile, portable cabinet with a tilt-bail stand and is readily converted to rack mounted configuration by installation of the rack mounting adapter kit.

1-7. Tabulated Data

a. Electrical

(1) Dc Voltage

Table 1-1. Dc Voltage Ranges

RANGE	MAX. RDG.	RESOLUTION	ACCURACY
2 V	± 1.99999 V	± 0.00001 V	± (0.01% of Reading + 1 LSD)
20 V	± 19.9999 V	± 0.0001 V	
200 V	± 199.999 V	± 0.001 V	
1000 V	± 1000.00 V	± 0.01 V	

LSD = Least significant digit

(a) Input impedance: >10,000 M Ω on 2V Range. **10 M Ω on 20V**, on 20V, 200 V and 1000 V Ranges.

(b) Input bias current: \leq 100 picoamperes at 20°C

(c) Normal mode rejection: >60 dB at 60 Hz (Filter In)

(d) Common mode rejection (with driven GUARD): \geq 120 dB at 60 Hz, \geq 140 dB at dc with **1k Ω** unbalance in either lead.

(e) Polarity Indication: Automatic

Temperature coefficient: 20.0007% of Rdg./°C

(g) Response time: \leq 2 seconds (Filter Out)

(2) Dc Voltage Ratio

(a) Ratio range: \pm 0.001% to \pm 100.000% to **\pm 1000.00%** to \pm 10000.0%

(b) Ratio accuracy: \pm (0.005% of Rdg. +1 LSD)

(c) Temperature coefficient: 20.0007% of Rdg./°C

(d) External reference voltage: \pm 1 V dc to \pm 10 Vdc to \pm 100 Vdc auto ranging on 20V, 200V and 1000V Ranging; \pm 1V to \pm 2V on 2V Range.

(e) Polarity of EXT REF voltage: Auto Polarity on all ranges

(f) Operation: True - Real Time 4 wire ratio

(g) Common mode voltage (EXT REF LO and INPUT LO): \pm 12 volts peak with EXT REF \pm 1V to \pm 11.5 V. \pm 30 volts peak with EXT REF \pm 11.5 V to \pm 100 V.

(h) Common mode resistance: > 1 Meg ohm

(i) Input indication: 2.2 M Ω on all ranges

(k) Response time: \leq 2 seconds

(3) Ac Voltage (True rms)

Table 1-2. Ac Voltage Ranges*

RANGE	MAX. RDG.	RESOLUTION
2 V	1.99999 v	10 UV
20 V	19.9999 V	100 UV
200 V	199.999 V	1 mV
1000 V	1000.00 V	10 mV

*Maximum signal input (dc + ac rms) between HI and LO terminals is limited to 10⁸ VHz.

Table 1-3. Ac Voltage Accuracy

FREQUENCY	ACCURACY **
dc (coupled)	± (0.1% of reading + 400 counts)
0.5 Hz to 1 kHz	± (0.2% of reading + 600 counts)
1 kHz to 30 kHz	± (0.2% of reading + 400 counts)
30 kHz to 100 kHz	± (0.8% of reading + 400 counts)
100 kHz to 300 kHz	± (1.5% of reading + 600 counts)
300 kHz to 1 MHz	± (3.0% of reading + 4000 counts)

** Applies from 20,000 counts to 199,999 counts over a 90 day period at + 23°C ±2°C. Relative humidity less than 90%.

(a) Input impedance: 1 M Ω shunted by less than 50 pF (less than 100 pF rear input)

(b) Temperature coefficient: ±(0.01% rdg + 6 LSD + 3 uV)/°C Up to 10 kHz. ±(0.02% rdg + 10 LSD + 3 uV)/°C for 10 kHz to 1 MHz.

(c) Low pass filter: -3 dB at 10 kHz

(d) Response time: ≤ 300 ms (to 40 Hz) normal. ≤ 30 sec (to 0.5 Hz) slow.

(e) Common mode rejection: ≥ 90 dB at 60 Hz

(f) Crest factor: Full range (199,999 counts) 5 to 1. Half range (100,000 counts) 10 to 1.

b. General

(1) Temperature: 0 to 50°C operating. -55°C to +75 C storage.

(2) Humidity: Meets requirements of MIL-STD-810; Procedure II, Method 507

(3) Altitude: Meets requirements of MIL-STD-810; Procedure 1, Method 500

(4) Shock and Vibration: Meets requirements of MIL-STD-810; Procedure IX, Method 514 and Procedure V, Method 516

(5) Ac voltage: 100/120/220/240 V ±10 % single phase, sinusoidal 50 to 400 Hz

(6) Power: 50 watts

(7) Display: 5½ digit, ± polarity sign, 7 segment LED, 0.43 inch (11 mm) character height, characters bright red

c. Mechanical

(1) Height: 3.50 inches (88.9 mm)

(2) Width: 16.75 inches (425.5 mm)

(3) Depth: 17.12 inches (434.8 mm) behind panel 17.625 inches (447.7 mm) overall.

(4) Weight: 18 lbs.

1-8. Hems Comprising an Operable Equipment

Digital Voltmeter AN/GSM-64C, power cable and test leads comprise an operable equipment.

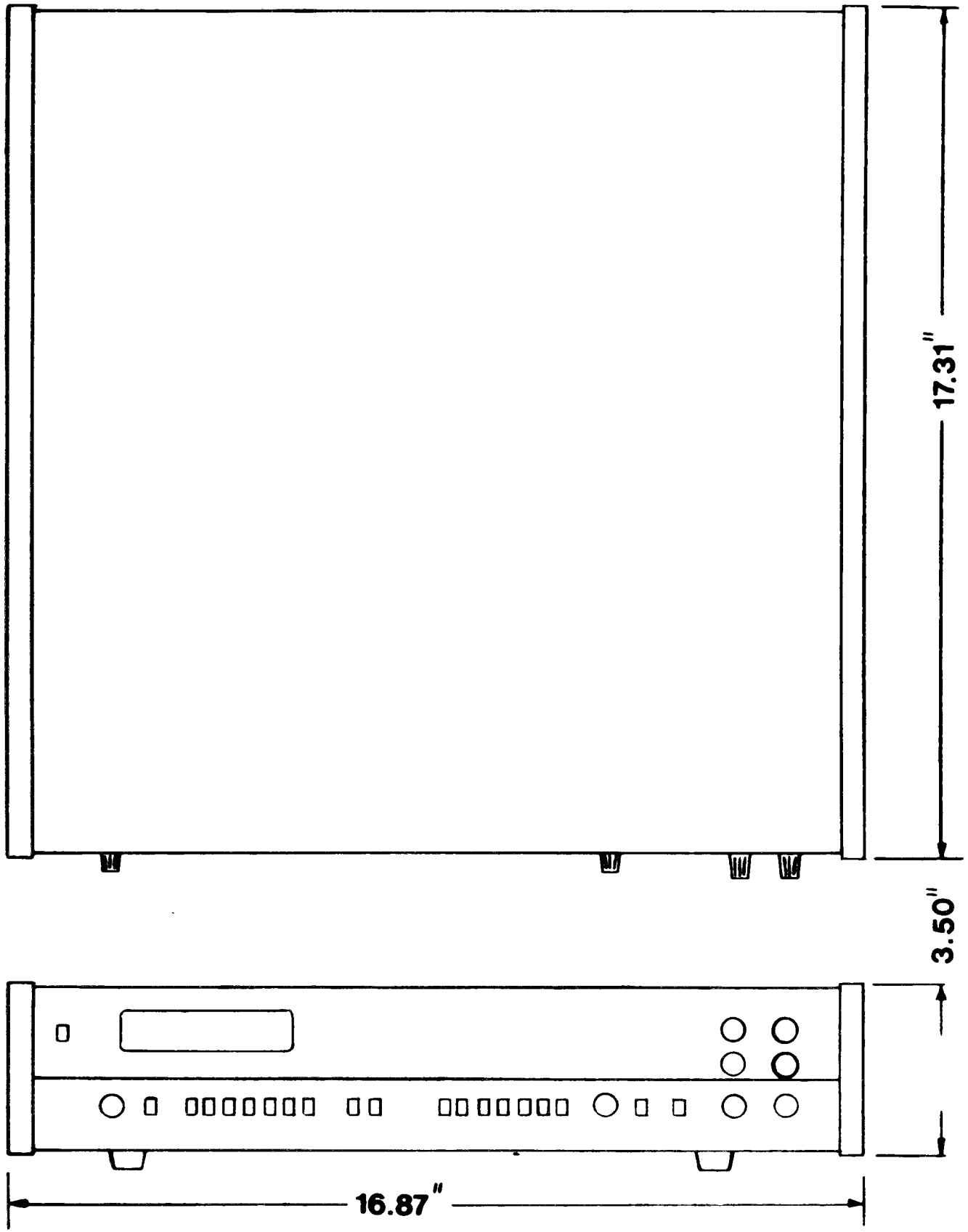

EL6UZ002

Figure 1-2. Outline Drawing, Portable Configuration

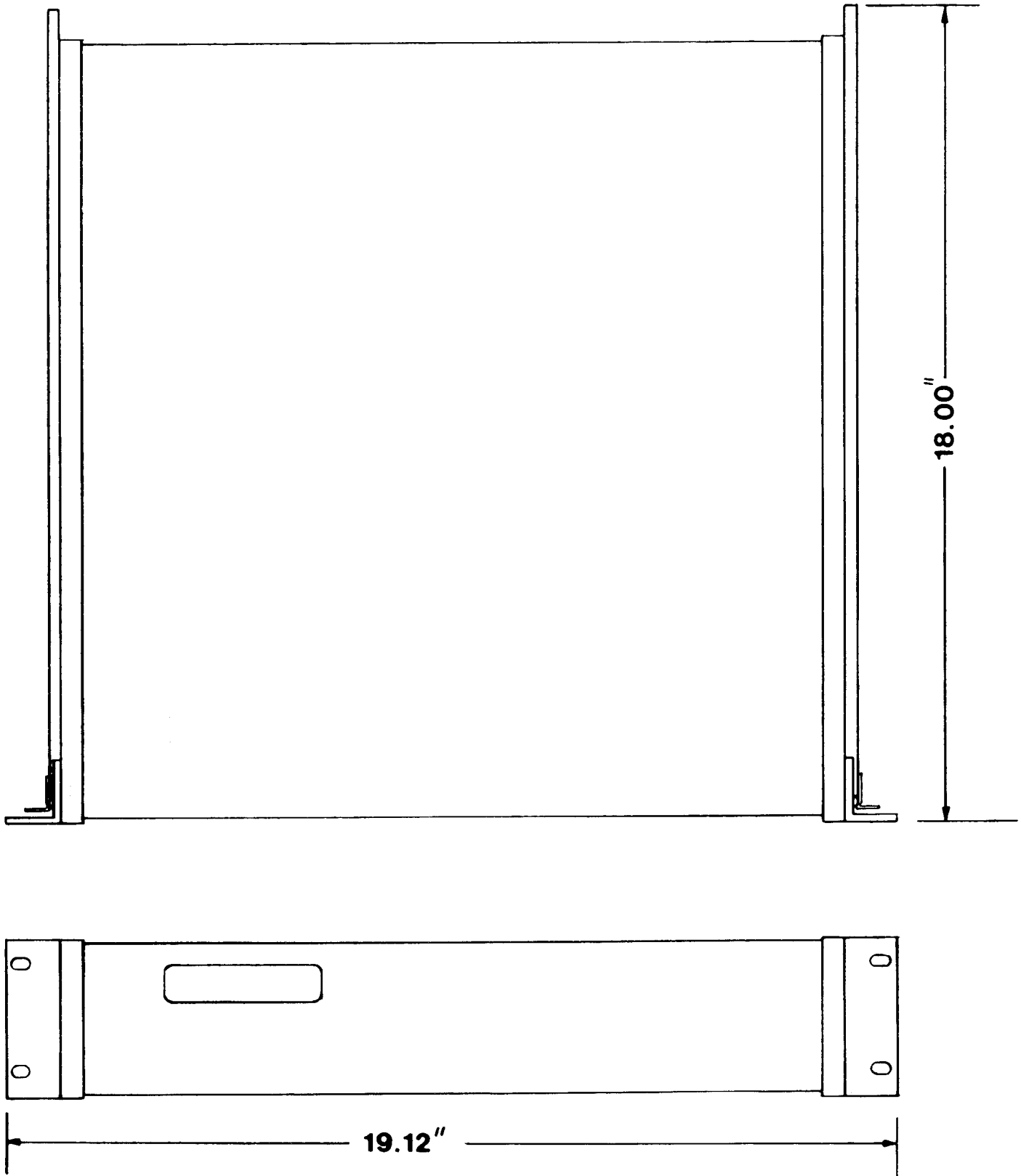

EL6UZ003

Figure 1-3. Outline Drawing, Rack Mount Configuration

CHAPTER 2

INSTALLATION

Section I. SERVICE UPON RECEIPT

2-1. Unpacking

Unpacking and initial inspection of the voltmeter requires only the normal precautions and procedures applicable to the handling of sensitive electronic equipment. A typical packaging diagram and its contents are shown in figure 2-1.

2-2. Checking Unpacked Equipment

a. Inspect the equipment for damage incurred during shipment. If the equipment has been damaged, report the damage on DD Form 6 (para 1-3).

b. Check the equipment against the component listing in the operator's manual and the packing slip to see if the shipment is complete. Report all discrepancies in accordance with the instructions of TM 38-750. The shipment should be placed in service even though a minor assembly or part that does not affect proper functioning is missing.

c. Check to see whether the equipment has been modified. (Equipment which has been modified will have the MWO number on the front panel, near the nomenclature plate.) Check also to see whether all currently applicable MWO have been applied. (Current MWO applicable to the equipment are listed in DA PAM 310-7.)

Section II. INSTALLATION INSTRUCTIONS

2-3. Portable Use

a. The voltmeter is shipped ready for use as a portable, bench-top instrument. If desired, it may be positioned at a raised angle on the bench by pulling out the tilt-bail stand.

b. Procedure

(1) To put the voltmeter into operation, first check the orientation of the printed circuit board in the ac power receptacle on the rear panel of the instrument (figure 2-2). Make sure that it matches the power mains voltage requirement; either 100 Vac or 120 Vac (115 Vac) or 220 Vac or 240 Vac.

NOTE

The printed circuit board may be inserted in any one of four positions. The voltage selected is indicated by the number visible when viewed through the rear window of the fused receptacle. The voltmeter is shipped with the board oriented for 120 Vac (115 Vac) operation.

CAUTION

Failure to orient the printed circuit board properly may cause serious damage to the instrument.

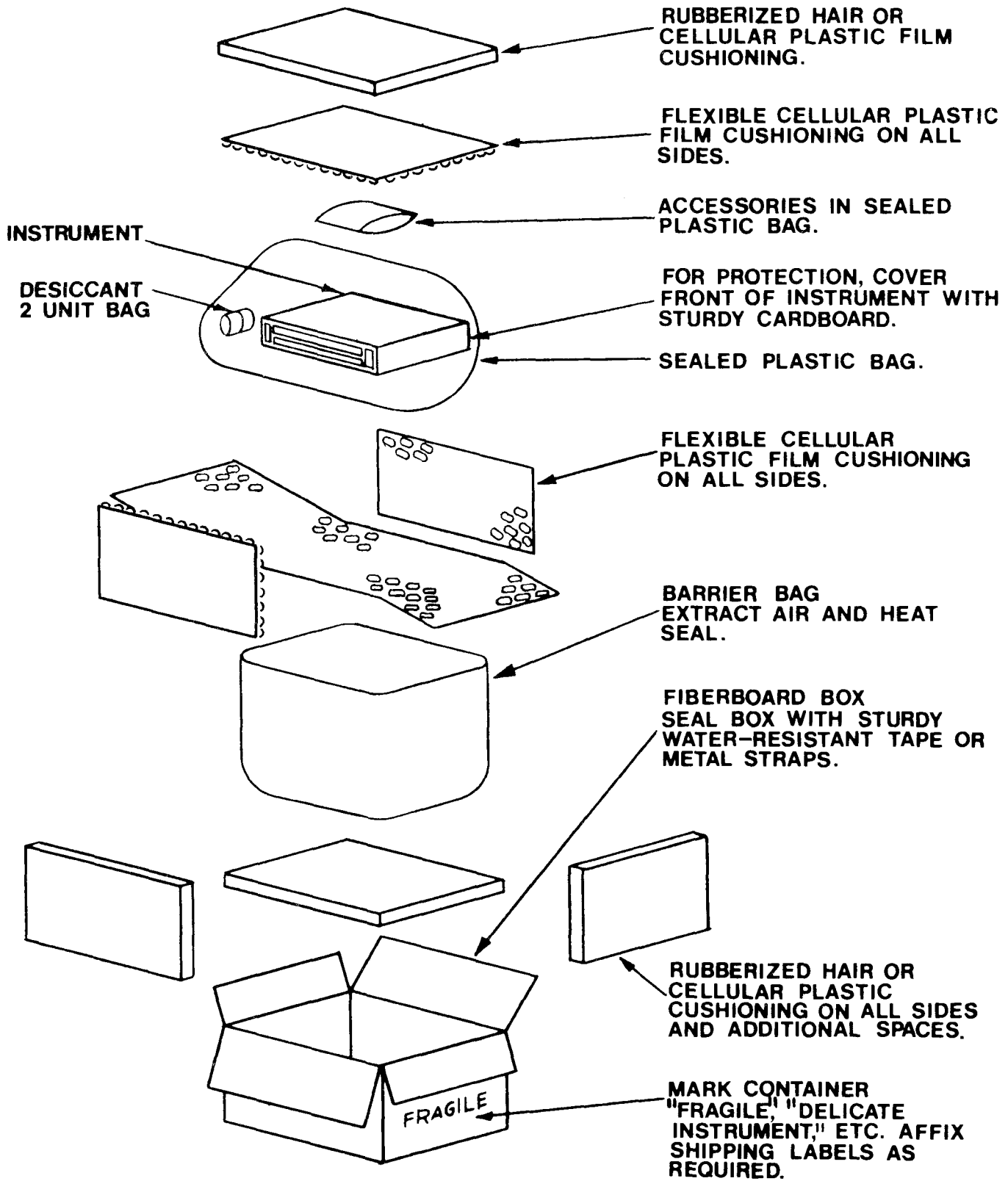

EL6UZ004

Figure 2-1. AN/GSM-64C Packing Diagram

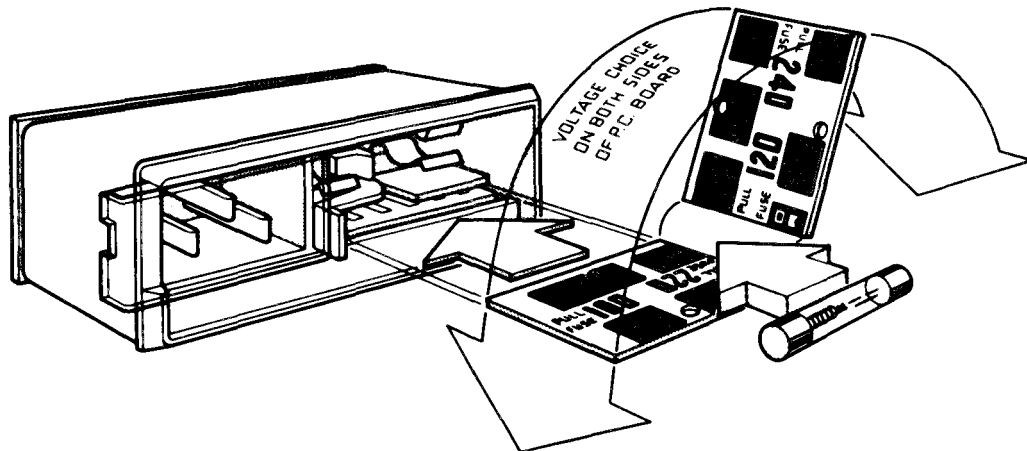

SELECTION OF OPERATING VOLTAGE

Operating voltage is shown in module window.

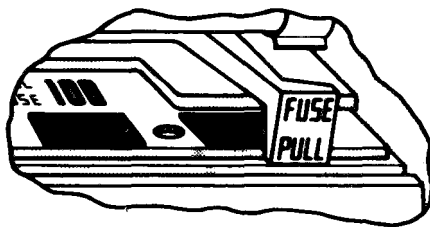

1. Open cover door and rotate fuse-pull to left.
2. Select operating voltage by orienting PC board to position the desired voltage on top-left side then push board firmly into module slot.
3. Rotate fuse-pull back into normal position and then re-insert fuse in holders, using caution to select correct fuse value.

EL6UZ005

Figure 2-2. Voltage Selection and Fused Receptacle (Rear Panel)

(2) Connect the line power cord to the input power receptacle on the rear panel and then plug it into a convenient line power receptacle.

CAUTION

Insure that the round pin on the line power cord is always connected to an "earth" ground.

(3) Make the appropriate connections to the front and rear panels as shown in figure 2-3. The voltage input can be applied to either the front or rear panel terminals. Selection of the terminals is accomplished by a front panel push-button switch.

2-4. Rack Installation

a. General. The voltmeter is readily adapted for installation in a standard 19-inch wide equipment rack by use of the rack adapter kit.

b. Procedure

(1) Remove the voltmeter bottom dust cover as detailed in paragraph 6-9. b.

(2) Remove the two rear feet from the dust cover.

(3) Remove the two front feet and tilt bail stand from the dust cover.

(4) Re-assemble the bottom dust cover to the voltmeter as detailed in paragraph 6-12. g.,

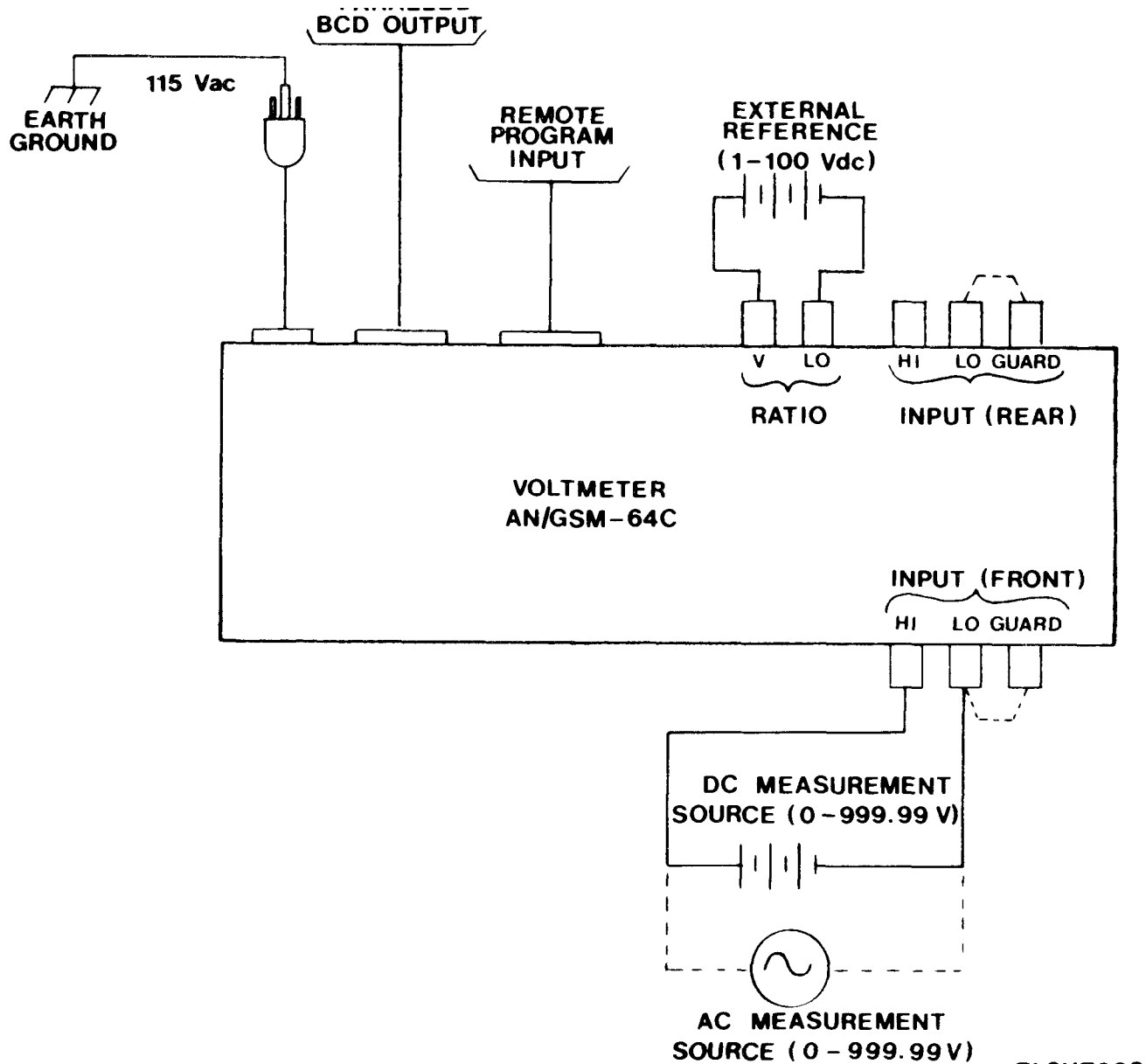

EL6UZ006

Figure 2-3. Equipment Connections

except use the two new screws supplied with the rack mounting kit.

(5) Remove the two No. 8 screws located on the right side casting near the front of the voltmeter. These empty threaded holes will be used in step (6).

(6) Mount one of the angle brackets to the right front side of the voltmeter by fastening it with the new No. 8 screws supplied with the kit. (Refer to figure 2-4.)

(7) Remove the two No. 8 screws located on the left side casting near the front of the voltmeter.

(8) Attach the other angle bracket to the left front side of the voltmeter by securing it with the new No. 8 screws supplied with the kit.

(9) To attach the right chassis-slide assembly, first unlatch and separate the inner member from two outer slide members.

(10) Orient the inner slide member so that the scalloped corner faces the upper front corner of the voltmeter right side.

(11) Fasten this inner member to the right side of the voltmeter with the three No. 8 screws supplied. (There are three threaded holes provided on the right side of the voltmeter.)

(12) Install the outer right slide assembly inside the right wall of the equipment rack frame.

(13) To attach the left chassis-slide assembly repeat steps (9) through (12) except orient the scalloped corner of the inner left slide member so that it faces the upper front corner of the voltmeter left side.

(14) Install the outer left slide assembly inside the left wall of the equipment rack frame.

(15) Position the voltmeter in the equipment rack and attach in place as shown in figure 2-4. It will be necessary to trip the latches on both the right and left voltmeter slide members to permit inserting the voltmeter completely into the equipment rack.

(16) The balance of this procedure is the same as the procedure given for installation of the portable configuration.

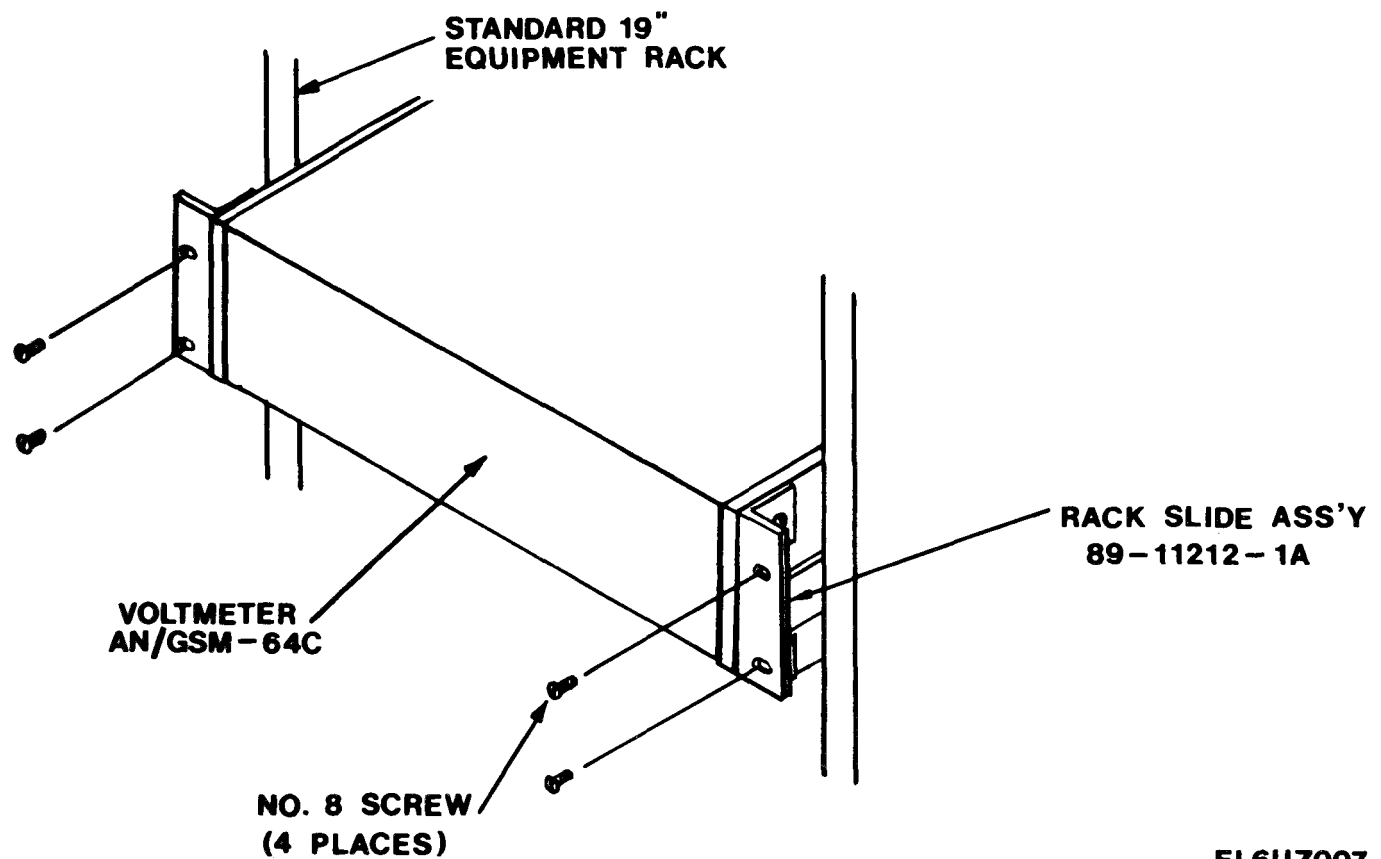

Figure 2-4 Rack Mount Installation

EL6UZ007

CHAPTER 3

OPERATING INSTRUCTIONS

Section I. CONTROLS AND INSTRUMENTS

3-1. General

This section fully describes the controls and instruments of the AN/GSM-64C Voltmeter. Figure 3-1 shows the location of each front panel control and instrument while figure 3-2 shows the location of the rear panel controls and instruments Table 3-1 describes the function of each front panel control and instrument while table 3-2 lists the function of each rear panel control and instrument.

3-2. Damage From Improper Settings

Voltages of up to 1000 Vdc or rms may be ap-

plied to the HI and LO terminals on any voltage range. Potentials of 200 V peak may be applied between the LO and GUARD terminals. Potentials of 300 V peak may be applied from GUARD to case.

CAUTION

Do not exceed the maximum potentials between terminals that are marked on the front and rear panels or damage to the equipment may occur.

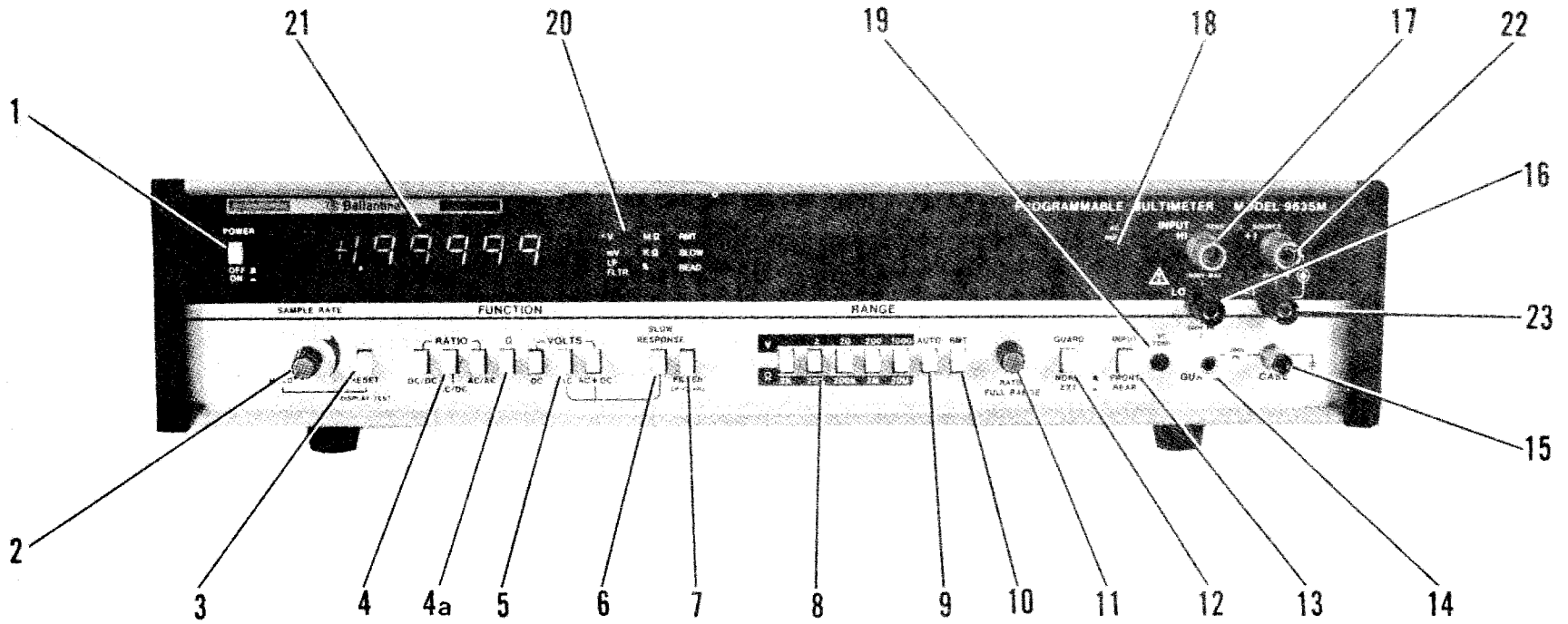

EL6UZ008

Figure 3-1. Front Panel Controls and Instruments

Table 3-1. Front Panel Controls and Instruments

Index No.	Control or Instrument	Function
1	POWER OFF/ON switch	Push on/push off switch that when pushed to the in position applies ac power to the voltmeter.
2	SAMPLE RATE control	Varies the sample rate from approximately 1 reading every 5 seconds (CW) to about 20 readings/second (CCW). When rotated fully counter-clockwise to the HOLD position, the last sample measurement is displayed until reset.
3	RESET/DISPLAY TEST switch	Momentary switch that initiates one sample reading each time it is depressed if the SAMPLE RATE control is in the HOLD position. If held in the depressed position, the status of the display is checked by displaying +1.88888.
4	RATIO DC/DC, AC/DC, AC/AC switches	Activates the ratio mode when the DC/DC switch is pushed in. The AC/DC and AC/AC positions are used only when the appropriate options are installed.
4a	Ω	Selects ohms function (optional).
5	VOLTS DC, AC, AC+DC switches	Selects the mode of voltage measurement; dc voltage (DC), ac rms voltage (AC) or ac and dc components combined (AC+DC).
6	SLOW RESPONSE switch	Push/push switch that when pushed to the in position the lowest specified AC Voltage frequency input is 0.5 Hz.
7	FILTER LP/10 kHz switch	Push/push switch that when pushed to the in position attenuates AC Voltage input frequencies above 10 kHz (-3dB at 10 kHz). Also selects additional normal mode filtering in DC Voltage and Ratio modes.

Table 3-1. Front Panel Controls and Instruments - Cont'd

Index No.	Control or Instrument	Function
8	RANGE switch	<p>Push button switches that select one of four voltage ranges; 2V, 20V, 200V and 1000V full scale.</p> <p style="text-align: center;">NOTE</p> <p style="text-align: center;">Ohms scale is optional</p>
9	AUTO	<p>Push/push switch that when pushed in to the AUTO position selects automatic ranging.</p>
10	RMT	<p>Push/push switch that when in the "out" position, disables remote control lines. Pushed in to the RMT position permits remote control of all front panel functions except ac POWER ON/OFF and FULL RANGE ADJUST RATIO. Disables front panel HOLD and RESET switches. Voltmeter continues to sample at rate set by SAMPLE RATE control.</p>
11	RATIO FULL RANGE	<p>Variable control that adjusts the ratio reading of identical input voltages to the INPUT and EXTERNAL REFERENCE voltages to be precisely 100%.</p>
12	GUARD NORM/EXT	<p>Push/push switch that when in the out position (NORM) connects the LO and GUARD INPUT terminals together internally. When pushed in to the EXT position, the LO and GUARD terminals are not connected together.</p>
13	INPUT FRONT/REAR	<p>Push/push switch that permits selection of either the front or rear panel INPUT terminals.</p>
14	INPUT GUARD	<p>Terminal for internal guard circuit connection when FRONT is selected.</p>
15	CASE	<p>Voltmeter chassis ground terminal (normally connected to "earth" ground).</p>

Table 3-1. Front Panel Controls and Instruments - Cont'd

Index No.	Control or Instrument	Function
16	INPUT LO	Low input terminal for connecting signal to be measured when FRONT is selected.
17	INPUT HI	High input terminal for connecting signal to be measured when FRONT is selected.
18	AC NULL	Adjusts for minimum reading on 2V full scale range in AC Voltage mode with INPUT terminals shorted.
19	DC ZERO	Adjusts for minimum reading on 2V full scale range in DC mode with INPUT terminals shorted.
20	Annunciators: V LP FILTER % RMT SLOW READ	Signifies that voltage mode has been selected. Illuminates when low pass filter has been selected. Indicates ratio mode has been selected. Illuminates when remote measurement mode is selected. Indicates when slow response has been selected for ac or ac+dc measurements. Annunciator lamp flashes at the beginning of a read cycle indicating the sample rate.
21	Display	5½ digit display with automatic polarity indication that presents measurement value of either voltage, ratio, or ohms depending on mode selected.
22	Ohms Source Terminal +i	Provides positive current source for 2 and 4 terminal ohms measurements when ohms option is installed.
23	Ohms Source Terminal -i	Provides negative current return for 2 and 4 terminal ohms measurements when ohms option is installed.

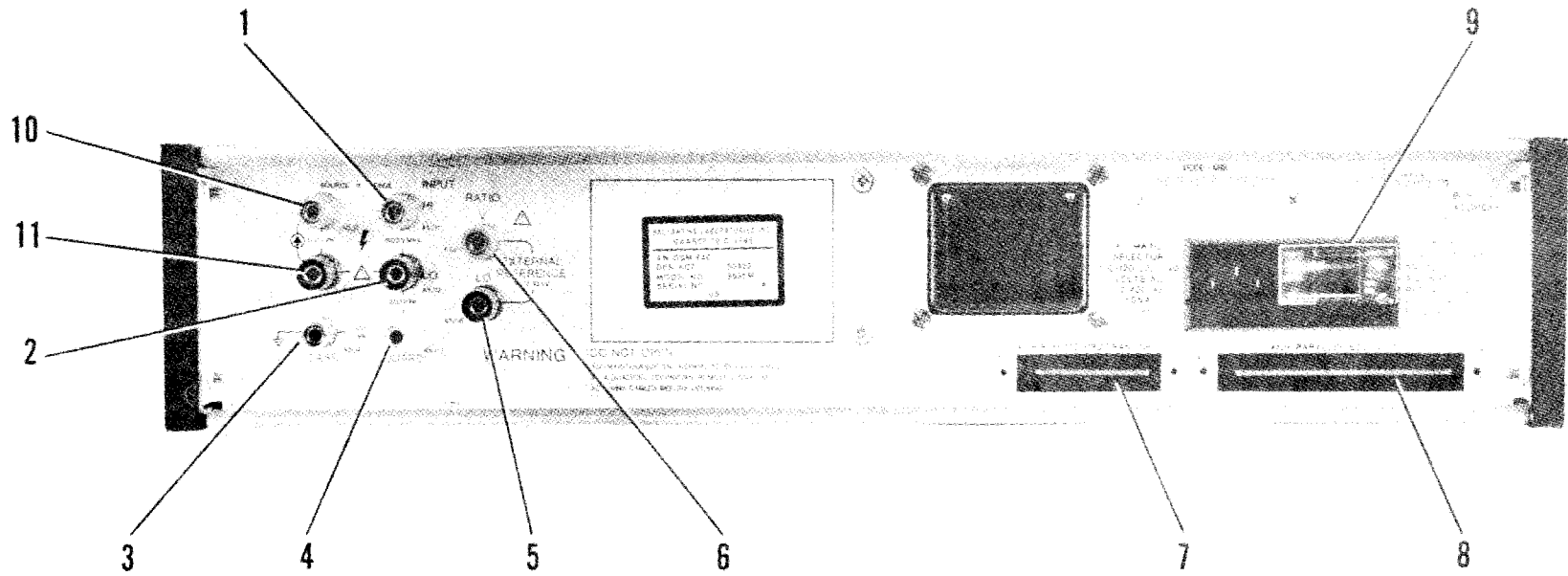

EL6UZ009

Figure 3-2. Rear Panel Controls and Instruments

Table 3-2. Rear Panel Controls and Instruments

Index No.	Control or Instrument	Function
1	INPUT HI	High input terminal for connection of signal to be measured when REAR is selected.
2	INPUT LO	Low input terminal for connection of signal to be measured when REAR is selected.
3	CASE	Voltmeter chassis ground terminal (normally connected to "earth" ground).
4	INPUT GUARD	Connects to internal guard circuit when REAR is selected.
5	EXTERNAL REFERENCE, LO (RATIO)	Low dc reference signal input terminal for 4 wire ratio measurements.
6	EXTERNAL REFERENCE, HI (RATIO)	High dc reference signal input terminal for 4 wire ratio measurements.
7	REMOTE PROGRAM INPUT	Connector for applying remote program commands when in RMT mode.
8	PARALLEL BCD OUTPUT	Connector that provides BCD output data for printout capability.
9	AC POWER CONNECTOR	Combination power receptacle, fuse holder and ac mains voltage selector that permits operation at either 100/120/220/240 Vat.
10	Ohms Source Terminal +i	Provides + source for 2 and 4 terminal ohms measurement.
11	Ohms Source Terminal -i	Provides return for 2 and 4 terminal ohms measurement.

3-3. Guarded Measurements

a. The AN/GSM-64C Voltmeter uses a guarded input system to minimize the affects of common mode noise. This permits fully floating measurements without degradation of accuracy. Guarded measurements should be made when:

(1) Long signal leads are used to connect to a high impedance source.

(2) Making a floating measurement in the presence of high common mode voltage and/or high frequency.

(3) Operating the voltmeter in the presence of high level, radiated noise such as stray fields at powerline frequencies.

b. For normal voltage measurements the GUARD terminal may be connected directly to the LO input terminal. The GUARD switch is provided for this convenience. Figure 3-3 shows the affect of measurements taken in a normal (NORM) condition while figure 3-4 illustrates how a guarded (EXT) measurement minimizes the affects of common mode noise by

shunting these currents away at the source.

WARNING

When making off-ground (guarded) measurements the internal guard shield may be at a dangerous potential to ± 300 volts with respect to case ground. Exercise proper personnel hazard precautions when connecting and disconnecting test leads.

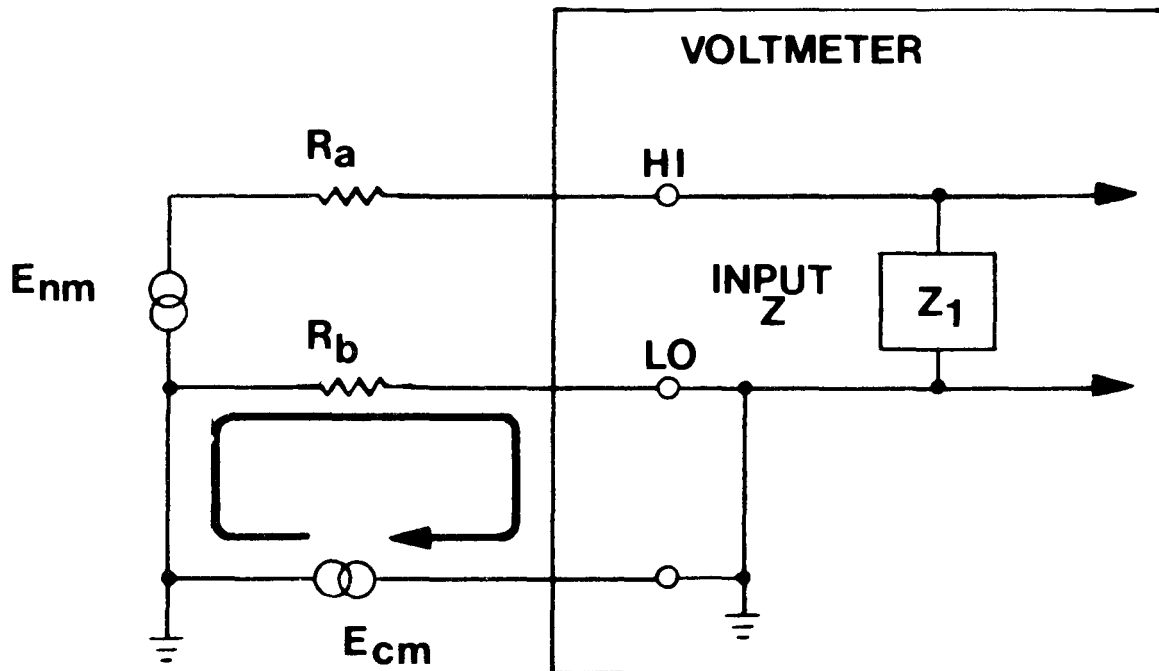

EL6UZ010

Figure 3-3. Common Mode Signal Configuration

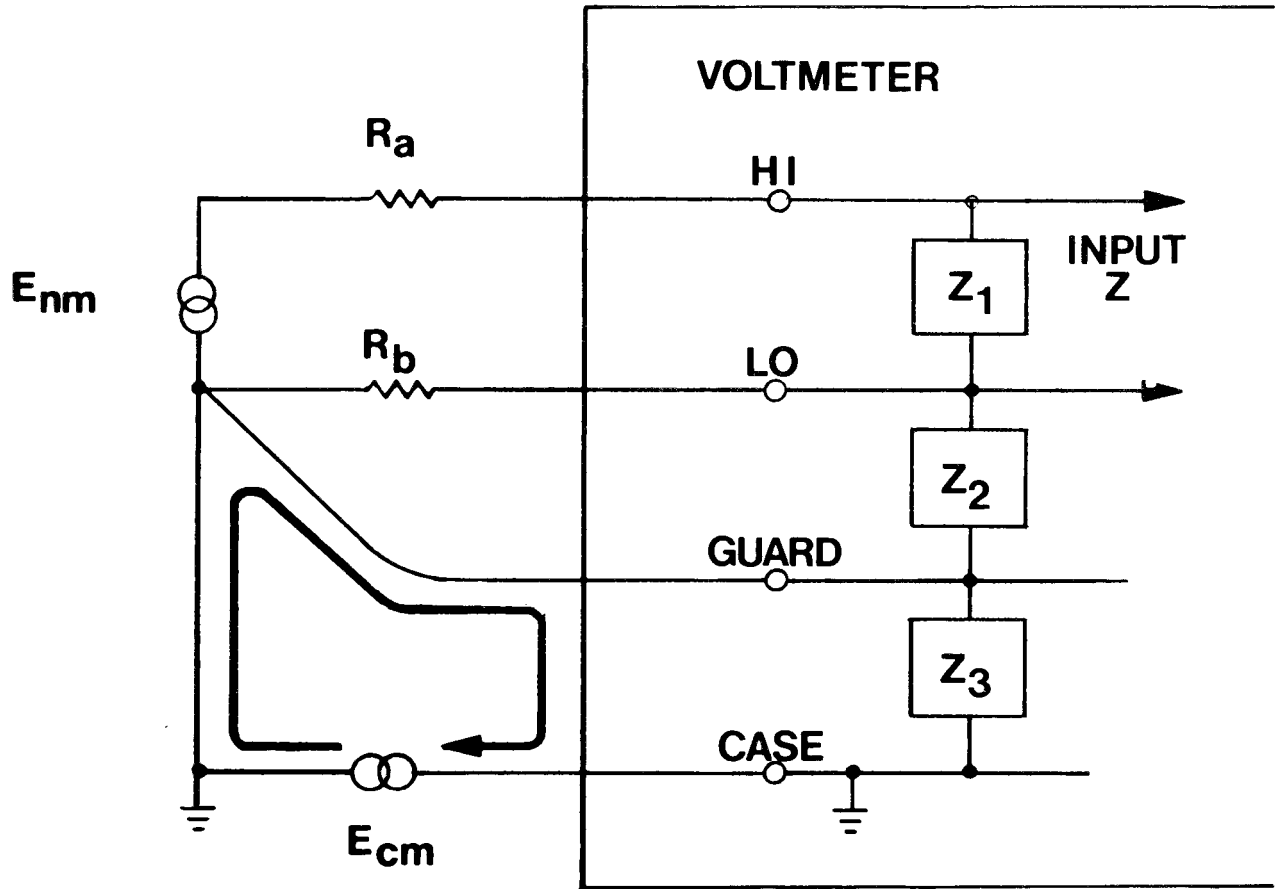

EL6UZ011

Figure 3-4. Guarded Signal Configuration

Section II. OPERATION UNDER NORMAL CONDITIONS

3-4. General

This section contains instructions and information required for operation of the voltmeter and radiometer. Procedures for both manual and remote operation are included as well as instructions for utilizing the BCD data output capability.

3-5. Preliminary Starting Procedure

- a. Plug the ac power cord in to a suitable ac power source. (Refer to paragraph 2-3.)
- b. Set the voltmeter controls as follows:

SAMPLE RATE	Counter-clockwise, but not in the detented HOLD position.
VOLTS	DC
SLOW RESPONSE	Out
FILTER LP/10 kHz	Out
RANGE	2 V
AUTO	Out
RMT	Out
GUARD	NORM
INPUT	FRONT

- c. Push the POWER switch in to the ON position.
- d. Hold the RESET switch in to the DISPLAY TEST position and observe that the display indicates +1.88888. Release the RESET switch.

e. Connect a shorting strap across the front panel HI and LO INPUT terminals and connect these to the case ground terminal.

f. Using a small screwdriver, adjust the DC ZERO control for a display reading of 0.00000.

Then carefully set the DC ZERO control to provide a "just tripped" to + polarity indication.

g. Push the VOLTS AC switch to the in position.

h. Using a small screwdriver, adjust the AC NULL control for a minimum reading on the display (within 300 least significant digits).

i. Disconnect the shorting strap from the HI and LO INPUT and case ground terminals.

WARNING

When measuring voltages above 30 volts, a shock hazard may exist. If necessary, turn off power to all associated equipment when connecting and disconnecting test leads.

3-6. Dc Voltage Measurement

The voltmeter will measure dc voltages from ± 0.0001 to ± 1000.00 volts on four separate ranges; 2, 20, 200 and 1000 V. Automatic ranging may be selected if desired. Polarity indication is automatically displayed.

- a. Set the controls as indicated in para 3-5.b.
- b. Connect the test leads to the HI and LO INPUT terminals, the red test lead to the HI terminal and the black test lead to the LO terminal.

NOTE

If a guarded measurement is not necessary, leave the GUARD switch in the NORM position which connects GUARD to INPUT LO. For measurements where GUARD is driven from an external source, push the switch in to the EXT position and connect the GUARD terminal to the driving source. See para 3-3.

c. Select the appropriate V RANGE if the approximate value of the input voltage is known; if time input voltage is unknown, select the auto-ranging mode by pushing the AUTO switch to the in position.

NOTE

When using the AUTO mode, the voltmeter will automatically up range to the next higher range when the count exceeds 195000; or it will down range to the next lower range when the count falls below 12000.

d. Push the POWER switch to the ON position.

e. Observe the display. It will indicate the measured dc voltage, presenting both magnitude and polarity. If the reading fluctuates due to the presence of noise in the dc signal, it may be improved by pushing the FILTER switch to the in position.

f. The 2 volt range features very high input impedance ($\geq 10,000$ megohms). This may cause display readings when the instrument is unterminated. Therefore, always test the voltmeter with a low impedance source and avoid excessively high source impedances (> 20 megohms) during actual measurements. To minimize measurement error, the voltmeter features very low input bias currents (< 100 picoamperes at 20°C). Input bias current will increase linearly with temperature changes since the input amplifier uses bipolar super beta construction.

NOTE

If it is more convenient to use the rear input terminals, push the INPUT switch in to the REAR position.

3-7. DC/DC Ratio Measurement

The DC/DC RATIO mode permits comparison of a measured input dc voltage to a dc refer-

ence voltage connected to the rear panel EXTERNAL REFERENCE terminals. In this measurement mode, the displayed reading is the ratio of the two voltages expressed in percent (%). The range of dc reference voltages that may be applied is from ± 1 V to ± 100 V. When the two voltages are equal, their ratio is 1 : 1 or 100%. Refer to table 3-3.

a. Set the controls as indicated in para 3-5.b.

b. Connect the input voltage as indicated in para 3-6.b.

c. Connect the external reference voltage to the EXTERNAL REFERENCE terminals on the rear panel.

d. Push the RATIO DC/DC switch to the in position.

e. Push the POWER switch to the ON position.

f. Initially set the input voltage to be the same as the reference voltage. This may best be accomplished by temporarily connecting the same voltage source to both the EXT REF and the INPUT binding posts.

g. Select a voltage range that will display a ratio of 100%. Refer to table 3-3.

h. Adjust the RATIO FULL RANGE control for a reading on the display of 100.000%.

i. Set the reference voltage to the required value and select the desired V RANGE. Refer to table 5-3. To assure best ratio measurement accuracies consider the 10 megohm V INPUT resistance and the 2.2 megohm EXT REF input resistance on the source resistance of the voltages being compared. As an example, the EXT REF input source resistance should be well below 100 ohms to avoid measurement errors of 0.005% due to the voltmeter loading the source.

Table 3-3. Ratio Initialization Voltages

V RANGE	Input Voltage	External Reference	Display (%)
2	± 1 V	± 1.0 V	± 100.000%
2	± 2 V	± 2.0 V	± 100.000%
20	± 2 V	± 2.0 V	± 100.000%
20	± 10 V	± 10.0 V	± 100.000%
200	± 100 V	± 100.0 V	± 100.000%
1000	± 100V	± 100.0 V	± 100.000%

j. Observe the display reading. It will indicate the ratio of the input voltage to the external reference voltage, up to a maximum of 19999.9%.

NOTE

The polarity of the displayed ratio reading is the algebraic sign of the quotient resulting from:

$$\frac{(\pm) \text{ INPUT V} \times 100}{(\pm) \text{ REFERENCE V}} = (\pm) \text{ RATIO in\%}$$

3-8. Ac Voltage Measurement

The voltmeter will measure true rms ac voltages from 0.0001 to 1000.00 volts on four separate ranges; 2, 20, 200 and 1000 V. Automatic ranging may be selected.

a. Set the controls as indicated in para 3-5.b.

NOTE

If a guarded measurement is not necessary, leave the GUARD switch in the NORM position. For guarded measurements, push the switch in to the EXT position. See para 3-3.

b. Connect the test leads to the HI and LO IN-

PUT terminals, the red test lead to the HI terminal and the black test lead to the LO terminal.

c. Push the AC VOLTS switch to the in position.

d. For input signals with frequency components higher than 10 kHz, leave the FILTER switch in the out position. Push the FILTER switch to the LP/10 kHz position when measuring low frequency signals (< 1 kHz) to insert the 10 kHz (-3 dB) low pass filter.

NOTE

For ac voltages having a frequency lower than 40 Hz it may be necessary to use the AC+DC VOLTS mode. If the low frequency input signal has a dc component, the dc may be blocked with a large capacitor connected externally in series with the HI INPUT binding post. Use only a high quality polypropylene dielectric extended foil capacitor.

e. For frequencies lower than 40 Hz, push the SLOW RESPONSE switch to the in position.

f. Select the appropriate V RANGE if the approximate value is known; if the voltage is unknown or its range will be extensive, select the autoranging mode by pushing the AUTO switch to the in position.

g. Push the POWER switch to the ON position.

h. Observe the display. It will indicate the measured true rms ac voltage.

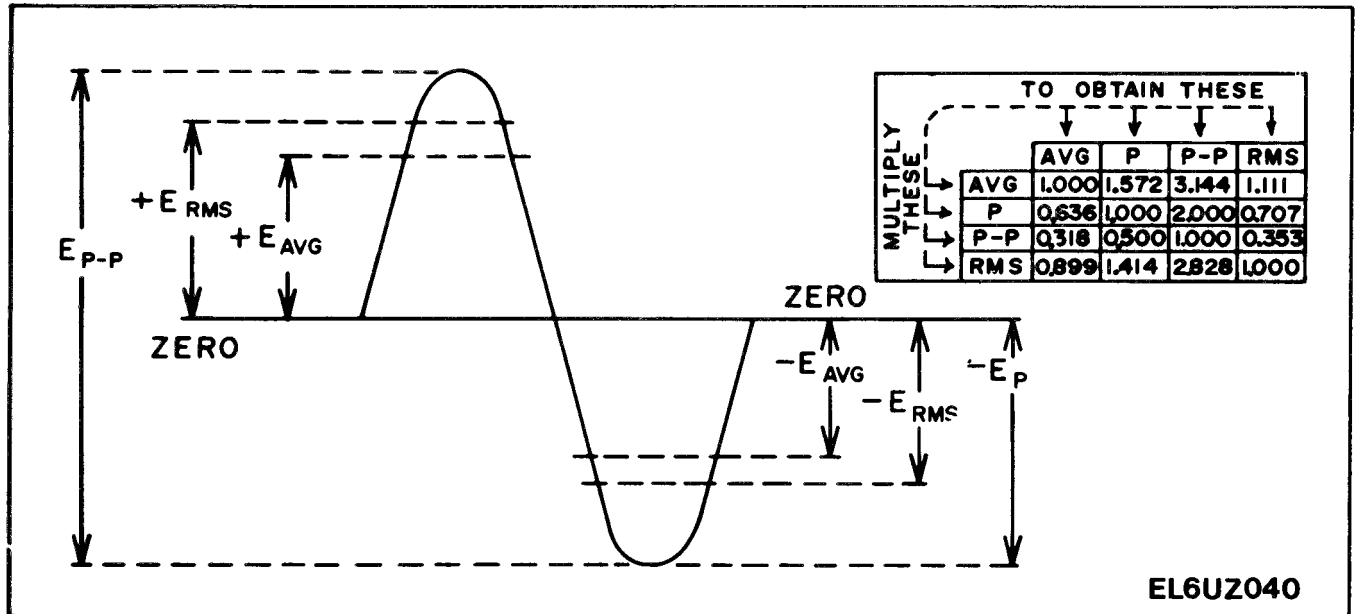

Figure 3-5. Average, Rms, and Peak Voltage Relationship of a Sine Wave

NOTE

The voltmeter will measure the rms value of a sine wave including the harmonics. It will respond to the rms value regardless of the phase of the input signal components. Figure 3-5 shows the sine wave relationship of average, rms and peak value.

b. Connect the test leads to the HI and LO INPUT terminals, the red test lead to the HI terminal and the black test lead to the LO terminal.

c. Push the AC+DC VOLTS switch to the in position.

NOTE

If a guarded measurement is not necessary, leave the GUARD switch in the NORM position. For guarded measurements push the switch in to the EXT position. See para 3-3.

3-9. Ac+Dc Voltage Measurement

The voltmeter is capable of making measurements of an ac rms voltage superimposed on a dc level. Being a true rms voltmeter, it responds to the heating factor of the composite waveform as given by:





$$E_{rms} = \sqrt{(Ac_{rms})^2 + (Dc)^2}$$

Refer to figure 3-6 for illustrations of the effect of a dc offset voltage on the rms value of a 10 V peak-to-peak square wave.

a. Set the controls as indicated in para 3-5.b.

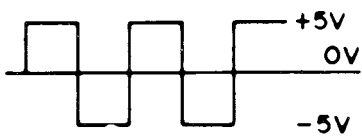
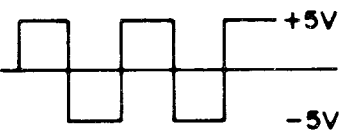
d. Push the FILTER switch in to the LP/10 kHz position if the frequency of signals to be measured is known to be lower than 10 kHz. For frequencies higher than 10 kHz, leave the FILTER switch in the out position.

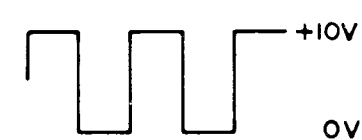
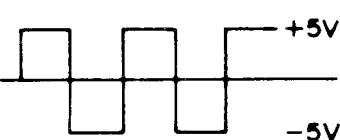
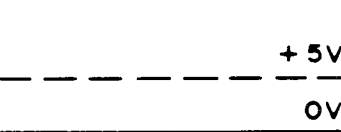
e. For frequencies lower than 40 Hz, push the SLOW RESPONSE switch to the in position to achieve specified accuracies. For frequencies higher than 40 Hz, leave the switch in the out position to obtain fastest readings.

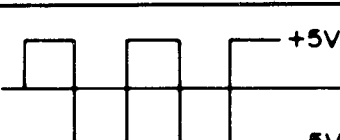
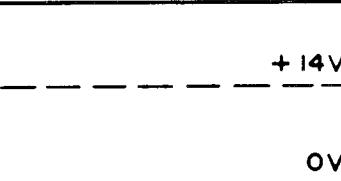
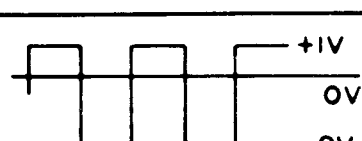
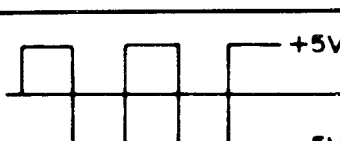
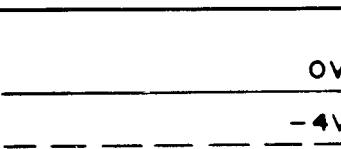
CASE	COMPOSITE WAVEFORM	AC COMPONENT ONLY	DC COMPONENT ONLY	TRUE RMS VOLTAGE OF COMPOSITE WAVEFORM $= \sqrt{(AC_{rms})^2 + (DC)^2}$
1	 +5V 0V -5V	 +5V -5V	 0V	$E_{rms} = \sqrt{5^2 + 0^2} = 5 \text{ V}$
2	 +10V 0V	 +5V -5V	 +5V 0V	$E_{rms} = \sqrt{5^2 + 5^2} = 7.07 \text{ V}$
3	 +19V +9V 0V	 +5V -5V	 +14V 0V	$E_{rms} = \sqrt{5^2 + 14^2} = 14.9 \text{ V}$
4	 +1V 0V -9V	 +5V -5V	 0V -4V	$E_{rms} = \sqrt{5^2 + (-4)^2} = 6.4 \text{ V}$

EL6UZO41

Figure 3-6. Effect of DC Bias on the True Rms Voltage of a Square Wave

f. Select the appropriate V RANGE if the approximate value is known; if the voltage is unknown or its range will be extensive, select the autoranging mode by pushing the AUTO switch to the in Position.

h. Observe the display. It will indicate the measured direct-coupled true rms ac voltage combined with the dc level on which it is super-imposed. (See figure 3-6.)

g. Push the POWER switch to the ON position.



3-10. Remote Programming

All of the functions and ranges of the voltmeter may be controlled remotely, with the exception of AC power, RATIO FULL RANGE ADJ., GUARD NORM/EXT, INPUT FRONT/REAR; via the REMOTE PROGRAM INPUT connector located on the rear panel. Refer to table 3-4 for information regarding remote programming.

NOTE

A logic low (0 to + 0.5 V) at the respective pin of A2J16 actuates the associated function.

Table 3-4. Remote Program Connector, A2J16

A2J16 Pin No.	Function	A2J16 Pin No.	Function
1	Digital COMMON ()	13	
2	HOLD (See note)	14	OHMS
3	2 k Ω RANGE	15	
4	RESET > 1 usec	16	AC VOLTS
5	2 V/ 20 k Ω RANGE	17	FILTER LP/10 kHz
6		18	AC + DC VOLTS
7	20 V/200 k Ω RANGE	19	SLOW RESPONSE*
8	DC/DC RATIO	20	
9	200 V/2 M Ω RANGE	21	
10	AC/DC RANGE	22	
11	1000 V/ 20 M Ω RANGE	23	
12	AC/AC RATIO	24	Case GROUND ()

* AC or AC + DC VOLTS mode only

If no RANGE is called; AUTO (Auto-range) is automatically selected.

If no FUNCTION called; DC VOLTS mode is automatically selected.

NOTE

A logic "low" disables read rate generator and enables remote reset line. Bringing remote reset line low for at least 1 usec will produce one sample reading.



Required 26 pin Remote Program Input Connector, Ballantine P/N: 31-10322-0A and 26 Wire Ribbon Cable, Ballantine P/N: 79-10111-0A.

3-11. BCD Output

Connector A2J14 provides parallel BCD output logic signals that are TTL compatible and

represent the status within the voltmeter. This information is suitable for long term monitoring by a printer. Table 3-5 lists the functions and logic levels for the BCD output information.

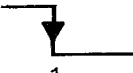
Table 3-5. BCD Output Logic

A2J14 Pin No.	Function	True Logic	A2J14 Pin No.	Function	True Logic
1	10 ⁰ Decade BCD 8	1	26	-	
2	10 ⁰ Decade BCD 2	1	27	m VOLTS	0
3	10 ⁰ Decade BCD 4	1	28	-	
4	10 ⁰ Decade BCD 1	1	29	k OHM	0
5	10 ⁰ Decade BCD 8	1	30	AC+DC VOLTS	0
6	10 ⁰ Decade BCD 2	1	31	M OHM	0
7	10 ¹ Decade BCD 4	1	32	SLOW RESPONSE*	0
8	10 ¹ Decade BCD 1	1	33	DC/DC RATIO	0
9	10 ² Decade BCD 8	1	34	X.XXXXX (DP 1)	0
10	10 ² Decade BCD 2	1	35	AC/DC RATIO	0
11	10 ² Decade BCD 4	1	36	XXXXX.X (DP 5)	0
12	10 ² Decade BCD 1	1	37	XX.XXXX (DP 2)	0
13	10 ³ Decade BCD 8	1	38	XXXX.XX (DP 4)	0
14	10 ³ Decade BCD 2	1	39	AC/AC RATIO	0
15	10 ³ Decade BCD 4	1	40	XXX.XXX (DP 3)	0
16	10 ³ Decade BCD 1	1	41	AC VOLTS	0
17	10 ⁴ Decade BCD 8	1	42	"-" Polarity	1
18	10 ⁴ Decade BCD 2	1	43	-	
19	10 ⁴ Decade BCD 4	1	44	+ 5 V	0
20	10 ⁴ Decade BCD 1	1	45	-	
21	Pos. Print Command		46	Overrange, Illegal Mode, Option Not Installed	0
22	10 ⁵ Decade BCD 2	1	47	-	
23	Neg. Print Command		48	-	
24	10 ⁵ Decade BCD 1	1	49	-	
25	FILTER LP/10 kHz	0	50	Digital Low (GND) 	

* AC or AC + DC VOLTS mode only

Required 50 pin BCD Output Connector, Ballantine P/N: 31-10323-0A and 50 wire ribbon cable, Ballantine P/N: 79-10112-0A.

3-12. Standby Operation

The voltmeter may be used instantly after turn-on, being of solid state design. However, to obtain optimum accuracy and minimize the need to adjust either DC ZERO or AC NULL; it is recommended that the instrument be allowed a 1/2 hour warm-up period.

3-13. Procedures for Shutdown

The voltmeter may be shutdown at any time regardless of whether any inputs are connected. To turn the voltmeter off, push the POWER OFF/ON switch to release it to the out (OFF) position.

Section III. PREPARATION FOR MOVEMENT

3-14. General

This section contains information regarding movement of the voltmeter. Rack removal is described first, followed by instructions for bench or shelf movement.

3-15. Bench/Shelf Movement

a. Set the POWER OFF/ON switch to OFF by releasing it to the out position.

b. Disconnect any test leads or cables from the front and rear panel terminals, if necessary.

c. Grasp the voltmeter and transport it to the desired location.

3-16. Rack Removal (Optional Rack Installation)

a. Set the POWER OFF/ON switch to OFF by releasing it to the out position.

b. Disconnect any test leads or cables from the front and rear panel terminals, if necessary.

c. Remove the voltmeter from the equipment rack by removing the front mounting screws from the brackets. (See figure 2-4.)

CHAPTER 4

OPERATOR AND ORGANIZATIONAL MAINTENANCE

Section I. TOOLS AND EQUIPMENT

4-1. General

This section contains a list of supplies required for operator and organizational maintenance. Special tools and test equipment issued with, or prescribed for use with, the voltmeter are listed

in the Tool and Test Equipment List, Appendix B. **4-2.**

Materials Required

The items listed in table 4-1 are required for operator and organizational maintenance.

Table 4-1. Material Required

	Qty.	Nomenclature	NSN
	8 oz.	Isopropyl Alcohol, Technical	6810-00-753-4993
	1 qt.	Commercial Detergent	
	1 can	Spray Lubricant, Centralab Spray Lubricant or equivalent such as WD-40.	

Section II. LUBRICATION

4-3. Lubrication

The only lubrication required is that the push-

button switch contacts receive a light application of spray lubricant. (table 4-3.)

Section III. PREVENTIVE MAINTENANCE CHECKS

4-4. General

a. This section describes preventive maintenance checks and services which may be performed by operator and organizational maintenance activities.

b. To insure that the voltmeter is always ready for operation, it must be inspected systematically so that defects may be discovered and corrected before they result in serious damage or failures. The necessary preventive maintenance checks and services to be performed are listed

and described in tables 4-2 and 4-3. The item numbers indicate the sequence of and minimum inspection required. Defects discovered during operation of the unit will be noted for future correction to be made as soon as operation has ceased. Stop operation immediately if a deficiency is noted during operation which would damage the equipment. Record all deficiencies together with the corrective action taken on applicable forms as prescribed in TM38-750. Instructions for performing the required checks are identified as periodic checks in this maintenance manual.

The voltmeter shall rechecked and serviced in accordance with tables 4-2 and 4-3.

NOTE

If the equipment must be kept in continuous operation, check and service only those items that can be checked and serviced without disturbing operation; make the complete checks and services when the equipment can be shut down.

4-5. Checks and Services

Table 4-2. Operator's Preventive Maintenance Check and Services

B - Before Operation Time Required: 06			D - During Operation	A - After Operation Time Required: 0.0
Interval and Sequence No.			ITEM(S) TO BE INSPECTED Procedure	Work Time (M/H)
B	D	A		
1	6		KNOBS, PUSHBUTTON SWITCHES, TERMINALS, CONNECTORS Inspect for damage, security or malfunction.	0.1
	7		DISPLAY AND ANNUNCIATORS Inspect for damage or malfunction.	0.1
2			TERMINALS AND CONNECTORS Secure or replace any items not securely installed or broken.	0.1
3	8		FUSE Inspect and replace defective fuse.	0.1
4			POWER CABLE Inspect and replace cracked, frayed or burned cable.	0.1
5	9		TEST LEADS Inspect and replace or repair defective test leads.	0.1

Table 4-3. Organizational Preventive Maintenance Checks and Services

W - Weekly			M - Monthly	Q - Quarterly
Interval and Sequence No.			ITEM(S) TO BE INSPECTED Procedure	Work Time (M/H)
W	M	Q		
1			<p>KNOBS, PUSHBUTTON SWITCHES, TERMINALS, CONNECTORS</p> <p>Inspect for damage, security or malfunction.</p>	0.1
2			<p>DISPLAY AND ANNUNCIATORS</p> <p>inspect for damage or malfunction.</p>	0.1
	1		<p>COVERS AND SHIELDS</p> <p>Repair or replace any visibly damaged covers or shields</p>	0.2
	2		<p>EXTERIOR SURFACES</p> <p>Clean with mild detergent mixed equally with water.</p>	0.2
		1	<p>INTERIOR SURFACES</p> <p>Remove dust with low pressure compressed air. Clean contacts and component terminals with brush dipped in Freon TF.</p>	0.2
		2	<p>KNOBS</p> <p>Secure or replace, as required, any loose or defective knobs.</p>	0.1
		3	<p>TERMINALS AND CONNECTORS</p> <p>Secure or replace, as required, any loose or broken items.</p>	0.1
3			<p>POWER CABLE</p> <p>Inspect and replace cracked, frayed or broken cable.</p>	0.1

Table 4-3. Organizational Preventive Maintenance Checks and Services-Continued

W- Weekly

M - Monthly

Q - Quarterly

Interval and Sequence No.			ITEM(S) TO BE INSPECTED Procedure	Work Time (M/H)
W	M	Q		
4		4	CHASSIS FEET Inspect and replace any cracked or broken feet.	0.1
			TEST LEADS Inspect and replace or repair defective test leads.	0.1
		5	TILT-BAIL STAND AND BRACKETS Inspect and replace defective tilt-bail stand.	0.1
		6	PUSHBUTTON SWITCH CONTACTS Lubricate all switch contacts with a light application of spray lubricant.	0.1

WARNING

To be usable for cleaning, the compressed air source must limit the nozzle pressure to no more than 29 pounds per square inch gauge (PSIG). Goggles must be worn at all times while cleaning with compressed air.

Section IV. TROUBLESHOOTING

4-6. General

This section contains troubleshooting instructions for the voltmeter. Any malfunction that is beyond the scope of operator or organizational maintenance shall be referred to direct and general support maintenance in Chapter 6.

4-7. Procedure

If the voltmeter fails to operate correctly, turn

it off and check the following items:

- a. Wrong control settings or improper input connections (para 3-3, 3-6, 3-7, 3-8, and 3-9).
- b. Damaged or incorrectly installed power cord.
- c. Defective power fuse (figure 2-2).

Section V. MAINTENANCE OF VOLTMETER

4-8. General

This section contains maintenance instructions applicable to operator and organizational activities. Maintenance of the voltmeter by these activities is limited to the following items:

- a. Fuse and knob replacement.
- b. Cleaning (para 4-10).
- c. Functional testing (para 4-11).

4-9. Removal/Replacement

a. Fuse Replacement. The power fuse F1 is located within the ac power connector assembly on the rear panel (figure 3-2).

To remove the power fuse, proceed as follows:

- (1) Disconnect the power cable from the fused receptacle.
- (2) Slide the clear plastic cover to the extreme left position (figure 2-2).
- (3) Grasp the FUSE PULL handle and swing it fully to the left. This will disconnect the right end of the fuse from its spring clip retainer.

(4) Grasp the right end of the fuse and pull it out from the left spring clip.

To install a replacement power fuse, proceed as follows:

- (5) Rotate the FUSE PULL handle back to its normal (fully right) position.
- (6) insert the new fuse fully into the spring clips.

CAUTION

To avoid damage to the voltmeter, replace defective fuse with one having identical rating.

(7) Slide the cover back to its normal (extreme right) position.

(8) Reconnect the power cable to the fused receptacle.

b. Knob Replacement. The SAMPLE RATE/HOLD and RATIO FULL RANGE knobs are replaced as follows:

To remove the knob refer to figure 4-1 and:

(1) Pry the cap (1) loose from center of the knob (2) using a small knife blade.

(2) Using a medium blade screwdriver, turn the screw in the center of the knob (2) counterclockwise until knob is free.

(3) Remove the knob from the shaft.

To install a replacement knob perform the following steps:

(4) Position the new knob on the shaft so that it is oriented correctly with the front panel.

(5) Using a medium blade screwdriver, tighten the screw in the center of the knob by turning the screw clockwise. Do not overtighten.

(6) Check that the knob is secure on shaft and will not slip under normal torque.

(7) Press the red cap firmly back into the center of the knob.

4-10. Cleaning

The exterior surface of the voltmeter should be cleaned periodically with a soft lint free cloth dampened with a solution of mild detergent mixed equally with water (table 4-1). To clean the interior surfaces, first remove dust with dry low pressure compressed air; then clean the switch contacts and component terminals with a brush dipped in Freon TF (table 4-1).

4-11. Functional Testing

The voltmeter should be checked for correct operation after any maintenance is performed. Appropriate checks are provided in paragraph 3-5. Satisfactory completion of these tests insure that the voltmeter is ready for operation.

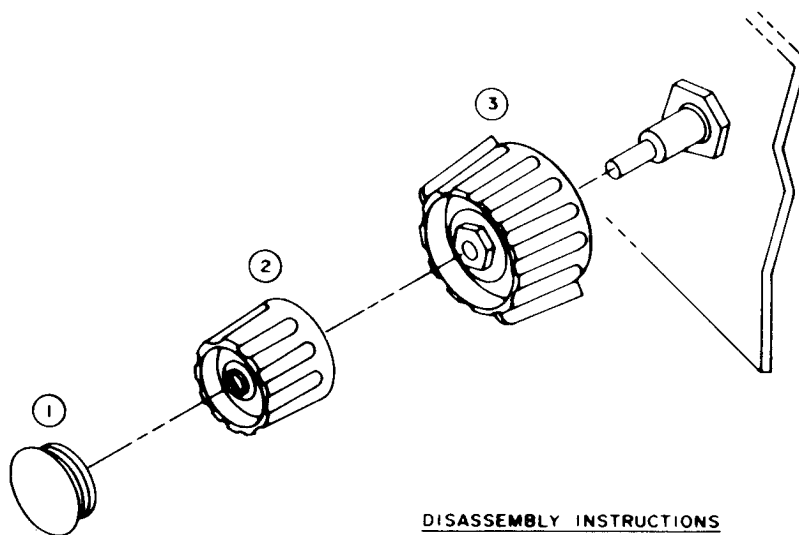

DISASSEMBLY INSTRUCTIONS

- STEP 1. PRY CAP (1) LOOSE FROM CENTER OF SMALL KNOB (2) WITH A SMALL KNIFE BLADE.
- STEP 2. USING A MEDIUM BLADE SCREWDRIVER, TURN SCREW IN CENTER OF SMALL KNOB (2) COUNTERCLOCKWISE UNTIL KNOB IS FREE; THEN REMOVE FROM SMALL DIAMETER SHAFT.
- STEP 3. USING A 3/8" NUT DRIVER, TURN NUT IN CENTER OF LARGE KNOB (3) COUNTERCLOCKWISE UNTIL KNOB IS FREE; THEN REMOVE FROM LARGE DIAMETER SHAFT.

EL6UZ012

Figure 4-1. Knob Removal and Replacement

CHAPTER 5

FUNCTIONING OF EQUIPMENT

Section I. BLOCK DIAGRAM ANALYSIS

5-1. Introduction

This section describes the operation of the major circuit functions of the voltmeter. First the dc voltage measurement mode is discussed; followed by ac voltage, dc ratio and the analog-to-digital (A/D) converter. For this discussion refer to the block diagram (figure FO-1).

5-2. Dc Measurement Mode

a. General. The voltmeter measures dc voltage up to ± 1000 V and presents the measured voltage on a 5% digit display. Four ranges are provided; 2, 20, 200 and 1000 volts full scale. The major circuit blocks discussed are: dc volts attenuator, dc buffer amplifier, active filter and the A/D buffer.

b. Dc Volts Attenuator. When the voltmeter is in the dc mode, signals are applied to the dc volts attenuator which provides an input impedance of $10\text{ M}\Omega$ on the 20 V, 200 V and 1000 V ranges. When the 2V full scale range is selected, signals are applied directly to the input of the dc buffer amplifier, A1-U1, and the input resistance is $10,000\text{ M}\Omega$. The 20V full scale range divides the input by a factor of 10 so that an input signal of 20 Vdc results in 2 Vdc applied to the input of A1-U1. The 200V full scale range divides the input voltage by 100 and the 1000V full scale range divides the signal by 1000. Thus, the maximum voltage presented to the dc buffer amplifier never exceeds 2 volts.

c. Dc Buffer Amplifier. The dc buffer amplifier (A1-U1) has an extremely high input impedance and has virtually no loading effect on the dc volts attenuator. The gain of U1 is 5X so that an input signal of 2, 20 or 200 V full scale results in a 10 V output signal. An input signal of 1000 V produces an output voltage of 5 V from U1. The DC ZERO adjustment balances the

buffer amplifier so that when the input signal is zero (input terminals shorted); there is 0 V output. U1 is overload protected to 1000 V dc or rms.

d. Active Filter. The dc output voltage of U1 is then applied to an active filter, A1-U100, that attenuates undesirable ac components of the dc signal. Two ranges of filtering are provided; when the FILTER push button switch is in the out (normal) position, the active filter attenuates 60 Hz ac components about 60 dB and has a response time of approximately 60 milliseconds (ins). With the switch pushed in, 60 Hz ac signals are attenuated approximately 100 dB but the response time is increased (slowed) to 600 ms.

e. A/D Buffer. The high impedance signal from the dc buffer amplifier is applied to the A/D buffer, A1-U104, which has a gain of unity and provides a low source impedance to the A/D converter input.

5-3. Ac Measurement Mode

a. General. The voltmeter measures the true rms of ac voltages over a frequency range of 0.5 Hz to 1 MHz. The voltage ranges are identical to those of the dc voltage mode. However, there are two modes of ac voltage measurement; ac and ac+dc. The major circuit blocks comprising the ac measurement mode are the preamplifier/scaler and true rms converter. After the true rms converter, the processing of the ac signal is identical to that of the dc signal (which was previously discussed in paragraph 5-21).

b. Preamplifier/Scaler. When the voltmeter is in the ac mode, signals are coupled through capacitor A7-C4 to the preamplifier/scaler

(A7-Q4A,B through A7-Q10,11). If the ac+dc mode is selected, then the signals are directly coupled to the preamplifier/scaler by the energizing of relay A7-K1. Relay A7-K2 connects A7-R8 to ground when it is in the "on" state (200 and 1000V ranges) and provides a 100:1 voltage divider in conjunction with the input resistor string; R1, R2, R3 and R4. This

attenuates the input signal by 40 dB. The gain of the preamplifier/scaler is changed by altering the feedback resistors. On the 2 and 200V ranges, the gain is unity; on the 20 and 1000V ranges the gain is reduced to 0.1 (-20 dB). Refer to table 5-1 for ac attenuation. A7-R23, AC NULL, balances the preamplifier for a zero input signal condition.

Table 5-1. Ac Attenuation

Range	Input Attenuation	Preamplifier Gain	Total Attenuation
1000V	40 dB	-20 dB	60 dB
200V	40 dB	0 dB	40 dB
20V	0 dB	-20 dB	20 dB
2V	0 dB	0 dB	0 dB

c. True Rms Converter. The ac output signal from the preamplifier/scaler is next applied to an active precision rectifier, A7-U1, through a switchable low pass filter that produces a -3 dB rolloff at 10 kHz. The half-wave output of the active rectifier is then combined with the ac signal (reduced to half that of the rectified signal) and the combined signal is directed to the summing amplifier, A7-U2. The output of the summing amplifier is a negative going, full-wave rectified signal. The rms converter module (A7-U3) is in the feedback loop of the summing amplifier and the feedback current is proportional to the output voltage of U2. Thus, U2 provides a voltage-to-current conversion that drives the input of the rms module.

age. For a 2 Vrms input at the front panel terminals, the dc output from U7 will be 2 Vdc. The transfer function of the true rms converter circuits is described by the following formula:

$$V_{out} = \sqrt{ac_1^2 + ac_2^2 + \dots + ac_n^2 + dc^2_*}$$

Where V_{out} = The dc equivalent of the applied rms voltage.

* When in AC + DC Mode

The output current (pin 7) of the rms module is fed to amplifier A7-U4, a current-to-voltage converter. The output of U4 is then applied to high impedance buffer amplifier A7-U7 through a three section, active filter A7-U6. U7 has a voltage gain of 2X, offsetting the loss in U2. In the NORMAL mode, the active filter operates down to 40 Hz and has a response time of 300 ms. When the switch is pushed in to the SLOW RESPONSE position, the filter operates to as low as 0.5 Hz with a response time of less than 30 seconds. The rms converter produces a dc voltage exactly proportional to the rms input volt-

This V_{out} dc signal is then directed to the dc buffer amplifier, A1-U1, and processed exactly the same as a dc signal (Dc Measurement Mode).

5-4. Dc Ratio Mode

a. The dc ratio mode of operation is the same as the dc measurement mode except that the dc voltage applied to the front panel input terminals is compared to a reference voltage applied to the rear panel EXTERNAL REFERENCE terminals.

b. Ratio Differential Amplifier. A dc reference voltage of either plus or minus polarity is connected to the RATIO (EXTERNAL REFERENCE) rear input terminals. Polarity detector A9-U54A will reverse the polarity of a negative reference voltage by actuating relay A9-K16 so the output

of the ratio differential amplifier, A9-U1, is always a positive voltage. The polarity sign of the displayed percent ratio will always be the algebraic equivalent of the input signal divided by the reference signal. Refer to table 5-2.

Table 5-2. Ratio Polarity

Input Signal Polarity	External Reference Polarity	Displayed Polarity
+	+	+
-	-	+
+	-	-
-	+	-

A9-U1 has unity gain for reference voltages up to 10.5 V but changes automatically to a gain of 0.1 for reference voltages between 10.5 and 100 V; thus the maximum full scale output of the ratio differential amplifier is +10.5 volts.

c. The ratio voltage is then applied through active filter A9-U100 (similar to that described in paragraph 5-3. c.) to the ratio output buffer amplifier, A9-U450. A9-R452, the RATIO FULL RANGE control, permits slight gain adjustments (less than/more than unity) of this amplifier so that when the reference voltage equals the input voltage; the displayed ratio reading can be normalized to 100.0007.

d. Ratio Autoranging Operation. The ratio amplifier voltage is then compared with the dc input voltage in the ratio up/down detectors, A1-U402 and U401 respectively. The output of the detectors, is an "up range command" for ratio counts higher than 180,000 or a "down range command" for ratio counts lower than 14,000 which is then applied to the up/down counter, A2-U51. This determines how many pulses from the auto range clock, A2-U60, are processed by

the auto ranging circuits. See table 5-3 for a listing of ratio ranging possibilities.

5-5. Analog to Digital (A/D) Converter

a. The resultant analog dc signal from the A/D buffer, A1-U 104, is applied to the analog to digital (A/D) converter. Here it is compared to a +10 V reference if the input signal is positive or to a -10 V reference if the input signal is negative (dc voltage mode only; its polarity automatically detected and displayed by the A/D converter. The analog signal is converted to a digital signal that is equivalent to 199,000 counts from the 12 MHz clock for a full scale reading, each time a sample reading is taken by the digital counter. A voltage measurement that is one-tenth the full scale range results in a count of 20,000 when a sample reading is taken.

b. The sampled pulses are applied to digital counters (A2-U354 through U358) and then sent to the 5½ digit display (A3) where they are presented as a voltage or ratio reading with polarity automatically indicated. The count is also converted to BCD and made available for external processing at the rear panel.

Table 5-3. Ratio Ranging

Range	Dc Input Voltage	EXT REF Input Voltage	Displayed Ratio %	EXT REF Voltage Operation - Limits
2V	$\pm 100 \text{ mV}$	$\pm 1 \text{ V}$	$\pm 10.000\%$	$\pm 1 \text{ V to } \pm 2 \text{ V}^*$
2V	$\pm 199 \text{ mV}$	$\pm 1 \text{ V}$	$\pm 19.999\%$	
2V	$\pm 1.0000\text{V}$	$\pm 1 \text{ V}$	$\pm 100.000\%$	
2V	$\pm 1.9999\text{V}$	$\pm 1 \text{ V}$	$\pm 199.999\%$	
2V	$\pm 1.00000\text{V}$	$\pm 2 \text{ V}$	$\pm 50.000\%$	
20V	$\pm 1.0000\text{V}$	$\pm 1 \text{ V}$	$\pm 100.000\%$	$\pm 1 \text{ V to } \pm 100 \text{ V}$
20V	$\pm 1.9999\text{V}$	$\pm 1 \text{ V}$	$\pm 199.999\%$	
200V	$\pm 10.000\text{V}$	$\pm 1 \text{ V}$	$\pm 1000.00\%$	
200V	$\pm 19.999\text{V}$	$\pm 1 \text{ V}$	$\pm 1999.99\%$	
1000V	$\pm 100.00\text{V}$	$\pm 1 \text{ V}$	$\pm 10000.0\%$	
1000V	$\pm 199.99\text{V}$	$\pm 1 \text{ V}$	$\pm 19999.9\%$	
20V	$\pm 1.0000\text{V}$	$\pm 10 \text{ V}$	$\pm 10.000\%$	$\pm 1 \text{ V to } \pm 100 \text{ V}$
20V	$\pm 1.9999\text{V}$	$\pm 10 \text{ V}$	$\pm 19.999\%$	
20V	$\pm 10.000\text{V}$	$\pm 10 \text{ V}$	$\pm 100.000\%$	
20V	$\pm 19.999\text{V}$	$\pm 10 \text{ V}$	$\pm 199.999\%$	
200V	$\pm 100.00\text{V}$	$\pm 10 \text{ V}$	$\pm 1000.00\%$	
200V	$\pm 199.99\text{V}$	$\pm 10 \text{ V}$	$\pm 1999.99\%$	
1000V	$\pm 1000.0\text{V}$	$\pm 10 \text{ V}$	$\pm 10000.0\%$	
200V	$\pm 100.00\text{V}$	$\pm 100\text{V}$	$\pm 100.000\%$	$\pm 1 \text{ V to } \pm 100 \text{ V}$
1000V	$\pm 100.00\text{V}$	$\pm 100\text{V}$	$\pm 100.00\%$	
1000V	$\pm 1000.0\text{V}$	$\pm 100\text{V}$	$\pm 1000.00\%$	

*For optimum Ratio performance within the EXT REF voltage operating limits of $\pm 1 \text{ V to } \pm 2 \text{ V}$ use the 2 volt RANGE. AUTO range operation in DC/DC RATIO mode is only applicable for input voltages greater than ± 2 volts using the 20V, 200V and 1000V ranges.

5-6. Auto Ranging

When the AUTO switch is pushed in to the AUTO position, ranging is automatically controlled by the up/down range detectors (A1-U404 and U405 respectively) and, in turn, the commands to the up/down counter. For automatic voltage ranging in the absence of any input signal, the

voltmeter will be in the 2V full scale range condition. When a voltage is applied that results in a count higher than (approximately) 195,000, the next higher range will be selected. The voltmeter is fully protected for any signal to $\pm 1000 \text{ Vdc}$ and 1000 Vac rms . If the voltage is changed to a level lower than (approximately) 12,000 counts, the next lower range will be selected.

Section II. LOGIC CIRCUIT DESCRIPTION

5-7. Introduction

This section contains detailed circuit description of the range, function and dc ratio logic circuits of the voltmeter. It includes logic truth tables to aid in locating and isolating a logic malfunction to a specific integrated circuit. Refer to the range and function selection diagrams, figures 5-1 and 5-2. In addition, figure 5-3 gives timing relationships that are helpful in understanding the analog-to-digital conversion process.

5-8. Range Logic Tables

To understand the range logic flow, refer to the Range Selection diagram, figure 5-1 and tables 5-4, 5-5, and 5-6. Manual inputs are applied through the front panel push buttons to A2-U57, the manual range decoder. This is a four-line BCD to ten-line decimal decoder.

The outputs from A2-U57 are then directed to the range encoder, A2-U67, an eight-line to three-line priority encoder. In parallel with these inputs, are range command signals from the remote input connector and the auto range decoder, U52. Depending on the "logic state" of A2-U57, pin 9 and 2, either manual, remote or auto range commands will be selected.

The three-line output of range encoder, A2-U67 is then applied through inverters to another decoder, A2-U250. There are really four input lines to A2-U250 but the "D" input is fixed at ground and thus; is always at a logic "low". This input logic to A2-U250 then selects one of the output lines to be "low". The "low" output line from this decoder determines which range has been selected.

Table 5-4. Manual Range Selection Logic, A2-U57

Range, Remote, Auto Select	Inputs				Output									
	A	B	C	D	0	1	2	3	4	5	6	7	8	9
	Pin No.				Pin No.									
	15	14	13	12	1	2	3	4	5	6	7	9	10	11
2 V	H	H	L	L	H	H	H	L	H	H	H	H	H	H
20 V	L	L	H	L	H	H	H	H	L	H	H	H	H	H
200 V	H	L	H	L	H	H	H	H	H	L	H	H	H	H
1000 V	L	H	H	L	H	H	H	H	H	H	L	H	H	H
REMOTE	H	H	H	L	H	H	H	H	H	H	H	L	H	H
AUTO	H	L	L	L	H	L	H	H	H	H	H	H	H	H

H = +5 V; L = 0 V

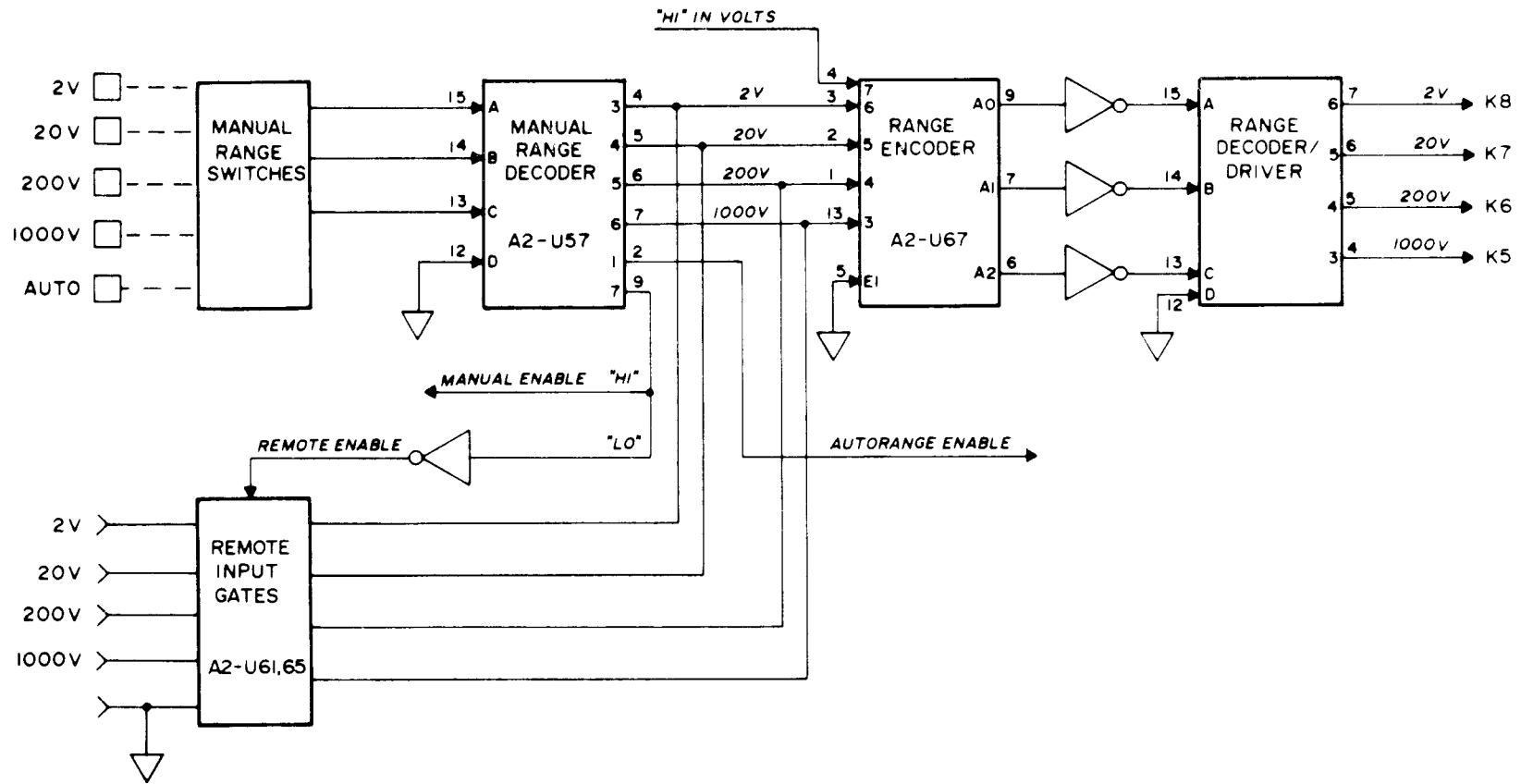

EL6U017

Figure 5-1. Range Selection Diagram

Table 5-5. Range Selection Logic, A2-LJ67

Range	Inputs										Outputs		
	E1	0	1	2	3	4	5	6	7	A0	A1	A2	
	Pin No.										Pin No.		
	5	10	11	12	13	1	2	3	4	9	7	6	
2 V	L	X	X	X	X	X	X	L	H	H	L	L	
20 V	L	X	X	X	X	X	L	H	H	L	H	L	
200 V	L	X	X	X	X	L	H	H	H	H	H	L	
1000 V	L	X	X	X	L	H	H	H	H	L	L	H	

L = 0 V; H = +5 Vdc; X = DON'T CARE

Table 5-6. Range Selection Logic, A1-U250

Range	Inputs				Output											
	A	B	C	D	0	1	2	3	4	5	6	7	8	9		
	Pin No.				Pin No.											
	15	14	13	12	1	2	3	4	5	6	7	9	10	11		
2 V	L	H	H	L	H	H	H	H	H	H	L	H	H	H		
20 V	H	L	H	L	H	H	H	H	L	H	H	H	H	H		
200 V	L	L	H	L	H	H	H	L	H	H	H	H	H	H		
1000 V	H	H	L	L	H	H	H	L	H	H	H	H	H	H		

L = 0 V; H = +5 V

5-9. Autorange Logic (A1 Assembly)

Refer to figure FO-5

The plus or minus dc output from Dc Buffer Amplifier, U1 pin 6, is applied to the input of the

autorange circuits. A full scale measurement (on any range) is equal to ± 10.00 volts dc from U1 and is equivalent to 199,999 counts. This signal is applied simultaneously to U404A, B (Up Range Detector) and U405A,B (Down Range Detector).

5-10. Up Range Detector, Minus Voltage

The reference input (inverting) to U404A pin 1 is set to produce -195,000 counts (approx. -9.75 volts) by adjusting R405. If a voltage > -9.75 volts (i.e. -9.80 volts) is applied to the non-inverting input (U404A pin 2), the high gain ($> 10,000$) operational amplifier will swing quickly to the negative supply voltage (-15 V). This will turn off the photo-cell in U406 and cause pin 5 to go high (+5 V). The result is a logic "high" at U50 pin 5; producing an "Up Range command".

If the output signal voltage is < -9.75 volts (i.e. -9.70 volts), then the open collector output of U404A goes towards the positive (+5 V) supply, causing the photo-cell in U406 to conduct. This results in a logic "low" at pin 5 of U406 and thus; a logic "low" at U50 pin 5. This causes the autorange circuits to stay (or hold) at the present range.

5-11. Up Range Detector, Plus Voltage

The reference input (non-inverting) to U404B pin 6 is set to produce +195,000 counts (approx. +9.75 volts) by adjusting R406. If a voltage $> +9.75$ volts (i.e. +9.80 volts) is applied to the inverting input (U404B pin 7), the high gain amplifier will swing to approx. the negative supply voltage (-15 V). This again results in a logic "high" at U50 pin 5 producing an "Up Range command".

If the output signal voltage is $< +9.75$ volts (i.e. +9.70 volts), then again a logic "low" will be presented to U50 pin 5. This causes the autorange circuits to stay (or hold) at the present range.

5-12. Down Range Detector, Minus Voltage

A reference voltage representing -12,000 counts is applied to the inverting input of U405B pin 7 and is set to approx. -0.6 volts by adjusting R408. If the voltage is $< \pm 0.6$ volts ($< 12,000$ counts) is applied to the non-inverting

input (U405 pin 6), the high gain output will swing towards the positive supply (+5 V). This causes a logic "high" to be present at NAND gate U403D pin 8 and because 4 (figure FO-5) is "high" (Autorange), the output of this gate (pin 10) is "low". This turns off the photo-cell U407 and causes a logic "high" to be present at U50 pin 9; producing a "Down Range command".

If the output signal voltage is > -0.6 V (i.e. -0.7 to -9.75 volts), then the output of U405B will swing to nearly the minus supply voltage (-15 V) and cause a logic "low" to be at U50 pin 9. This tells the autorange circuits to remain at the present range.

5-13. Down Range Detector, Plus Voltage

A reference voltage representing + 12,000 counts is applied to the non-inverting input of U405A pin 2 and is set to approx. +0.6 volts by adjusting R407. If a voltage $< \pm 0.6$ volts ($< 12,000$ counts) is applied to the inverting input (U405A pin 1), the output will swing towards the open collector supply voltage of +5 V. This results in a "low" from U403D pin 10, turning off the U407 photo-cell and causing a logic "high" to be present at U50 pin 9. This produces a "Down Range command".

If the signal voltage is $> +0.6$ V (i.e. +0.7 to +9.75 volts), then the output of U405A will swing to the minus supply voltage (-15 V). This results in a logic "low" at U50 pin 9 causing the autorange circuits to remain at the present range.

5-14. Autorange Logic (A2 Assembly)

Refer to figures FO-8 & FO-11

Up Range Command: On any range except the 1000 V range, a logic "high" is present at U50B pin 6 enabling the NAND gate. When a "high" (Up Range command) is applied to U50B pin 5, a logic "low" is at the output (pin 4). This "low" is directed to pin 5 of U51, the BCD Up/Down (U/D) Counter, enabling it. The "high" (Up Range command) is also steered to U51 pin 10; selecting the up-count mode, see table 5-7

Table 5-7. Autorange Logic, A2-U52

Range	Inputs				Outputs										
	A	B	C	D	0	1	2	3	4	5	6	7	8	9	
	Pin No.				Pin No.										
	15	14	13	12	1	2	3	4	5	6	7	9	10	11	
2V	L	L	L	L	L	L ¹	L ²	H	H	H	H	H	H	H	
2V	H	L	L	L	L ¹	L	L ²	H	H	H	H	H	H	H	
2V	L	H	L	L	H	H	L	H	H	H	H	H	H	H	
20V	H	H	L	L	H	H	H	L	H	H	H	H	H	H	
200V	L	L	H	L	H	H	H	H	L	H	H	H	H	H	
1000V	H	L	H	L	H	H	H	H	H	L	L ³	L ³	H	H	
1000V	L	H	H	L	H	H	H	H	H	L ³	L	L ³	H	H	
1000V	H	H	H	L	H	H	H	H	H	L ³	L ³	L	H	H	

L = 0 V; H = +5 V

NOTES:

1. Pins 1 and 2 are connected together
2. Low because of "NAND" gate U61B
3. Pins 6, 7, 9 are connected together

The clock pulses from the Timer, U60 pin 9, are applied to pin 15 of the U/D Counter. These clock pulses have a rate of 4 Hz (one pulse every 250 milliseconds) and time the BCD output of the Autorange U/D Counter. This provides the Q1, Q2 and Q3 inputs to the Autorange Decoder U52 (A, B, C respectively). When the AUTO (range) mode is selected, a logic, "low" is connected to U52 pin 12, providing the "D" input.

Down Range Command: When a logic "high" (Down Range command) is applied to U50C pin 9, a logic "low" is then at the output (pin 10). This "low" enables the U/D Counter. Because a "low" is at U51 pin 10, the down-count mode is selected. When autoranging has ranged down to the 2 V range, a logic "low" is at U54 pin 11 and

a "high" at U50A pin 3, In Voltage mode, a logic "high" is also present at pin 2; thus a "low" at pin 1. This disables U50C NAND gate and as a result; the Up/Down Counter.

5-15. Remote Autorange

When no remote input range is selected, (all remote lines "high") the output of NAND gate U643 (pin 6) is "low". This "low" is applied through an inverter, becoming a "high", to NAND gate U6113 pin 11. In REMOTE mode, the other gate input (pin 12) is also "high" resulting in a "low" out. This output is connected to the "Auto Enable" input (pin 12) of the Autorange Decoder, U52 (which requires a "low" to enable) and puts the voltmeter in the remote autoranging condition.

5-16. Ratio Autoranging (A1 Assembly)

In addition to the autoranging circuitry already discussed for voltage mode in paragraphs 5-9 through 5-13, circuitry precedes it which is used for the ratio autoranging. To better understand the sequence of autoranging in the RATIO mode, the following brief description is given. Refer to schematic diagram, figure FO-5.

5-17. Ratio Up Range Detector, Plus Input Signal

For the sake of discussion, the following example is for an input voltage of +90 V (on the 200 V full scale range) and a reference voltage of 50 V. (Regardless of the polarity of the applied reference voltage, it will be presented to the ratio up/down range detectors as a positive voltage.) This ratio has been chosen because it is right at the threshold of up-ranging (>180,000 counts).

When the RATIO mode is selected, a logic "low" is present at (4) (figure FO-5) causing a "high" at U403B, enabling it. This also presents a "low" at U403D pin 9, disabling it; thus preventing the output of U405 from being "gated through" to U407.

An input of +90 volts to the voltage input terminals will be attenuated by 40 dB to +0.9 volts when on the 200 V range. The Dc Buffer Amplifier then amplifies this signal by 5, increasing it to +4.5 volts. This voltage is next applied to pin 1, the inverting input of U402A.

The 50 V ratio reference voltage, because it exceeds 10.5 volts, is attenuated by 20 dB in A9-U1 to +5 volts. Through the action of the voltage divider comprised of RN401-1,16 and RN403-1,7; the actual voltage presented to pin 2 of U402A is also +4.5 V. When the level at pin 1 (input signal) increases to only a few millivolts higher than that at pin 2, the reference becomes negative with respect to the input signal causing the output of U402A to swing towards the negative supply voltage (-15 V). This results in a "low" at the input of U403A (used as an inverter) and then a "high" at pin 3 of U403B. Pin 2 of U403B is also "high" because RATIO mode has been selected. This provides a "low" at the output of this NAND gate which is the correct logic for an "Up Range command" to U406.

5-18. Ratio Up Range Detector, Minus Input Signal

For the same ratio voltage conditions as given in the previous paragraph, except a -90 V input signal is applied, the signal present at the junction of RN401-2,15 and RN403-8,9 is -4.5 V. A +5 V signal (reference) is present at RN403-9,10. The voltage "summed" at the junction of these two resistors is approx. 0 volts. This level is applied to the non-inverting input of U402B.

The inverting input, pin 7, of U402B is adjusted to be "0" volts by R404. If the input signal then goes slightly more negative (< -90 V), the resulting signal at the input of U402B pin 6 will be slightly negative. This causes the op-amp to swing towards the negative supply voltage of -15 V, again producing an "Up Range command".

5-19. Ratio Down Range Detector, Plus input Signal

The following discussion uses the example of a +14 V input voltage (on the 200 V full scale range) and a 100 V reference voltage. This ratio has been selected because it is right at the threshold of down-ranging (c 14,000 counts).

As in the up range situation, a +14 V input signal is attenuated 40 dB on the 200 V range, to +0.14 volts. The Dc Buffer Amplifier then increases the gain of the input signal by a factor of 5, to +0.7 V. Because the ratio down range detector deals with low signal levels, the input signal is further amplified by 20 dB in U400. This +7 V signal is now applied to the inverting input of U401A pin 1.

The 100 V reference voltage is attenuated by 20 dB in the Dc Ratio Amplifier to become 10 V. The divider action of RN401-3,14 and RN403-1,6 produces a +7 V reference input to the non-inverting input of U401A pin 2.

When the signal voltage drops to just below +14 V, the resulting dc voltage at U401A pin 1 becomes slightly less than +7 V or, negative with respect to the reference voltage at pin 2. This causes the output of U401A to swing positive towards the open collector supply voltage of +5

V. This applies a logic "high" to U403C pin 11; pin 12 of U403C is already enabled because the RATIO mode has been selected. The output of NAND gate U403C pin 13 is a logic "low". This "low" is applied to photocell U407, producing a "Down Range command".

the output of operational amplifier, U401B to swing towards the open collector supply voltage of +5V. This again results in a logic "low" at the photo-cell, U407, producing a "Down Range command".

5-20. Ratio Down Range Detector, Minus Input Signal

When a -14 V input voltage is used, the voltage at the output of U400 becomes -7 V. For the same 100 V reference voltage, a +10 V reference will be present at RN403-10, 11. These two voltages are "summed" at the junction of RN403-10,11 and RN403-11,12 and the resulting voltage level is 0 V. This voltage is applied to the non-inverting input of U401B (pin 6). A reference voltage of "0" V, set by adjustment of R402, is applied to the inverting input of U401B (pin 7). If the -14 V input signal becomes slightly less negative, then the -7 V at RN403-11,12 also becomes slightly less negative; the voltage at the summing point goes slightly more positive than 0 volts. This causes the output of operational amplifier, U401B to

5-21. Function Logic Tables

To understand the function logic, refer to the Function Selection diagram, figure 5-2, and tables 5-8 and 5-9. Manual inputs are applied through front panel push button switches to gates A2-U1 and A2-U2. These gates are enabled when the output logic of A2-U57, pin 9 is "high". When this logic is "low", the remote input gates, A2-U12 and A2-U13 are enabled. Either the manual or remote input logic is directed to the function encoder, A2-U8, an eight-line to three-line priority encoder.

The output of A2-U8 is applied through inverters as a BCD input to Function Decoder, A2-U251. This input logic then selects one of the output lines to be "low" which determines the function selected.

Table 5-8. Function Select Logic, A2-U8

Function	Inputs									Outputs			
	E1	0	1	2	3	4	5	6	7	A0	A1	A2	E0
	Pin No.									Pin No.			
	5	10	11	12	13	1	2	3	4				
DC/DC RATIO	L	X	X	X	X	X	L	H	H	L	H	L	H
DC VOLTS	L	H	H	H	H	H	H	H	H	H	H	H	L
AC VOLTS	L	L	H	H	H	H	H	H	H	H	H	H	H
AC+DC VOLTS	L	X	X	X	L	H	H	H	H	L	L	H	H
FILTER (AC)	L	X	X	X	X	X	X	L	H	H	L	L	H
FILTER(AC+DC)	L	X	X	X	X	X	X	X	L	L	L	L	H

L = 0 V; H= +5 V; X= DON'T CARE

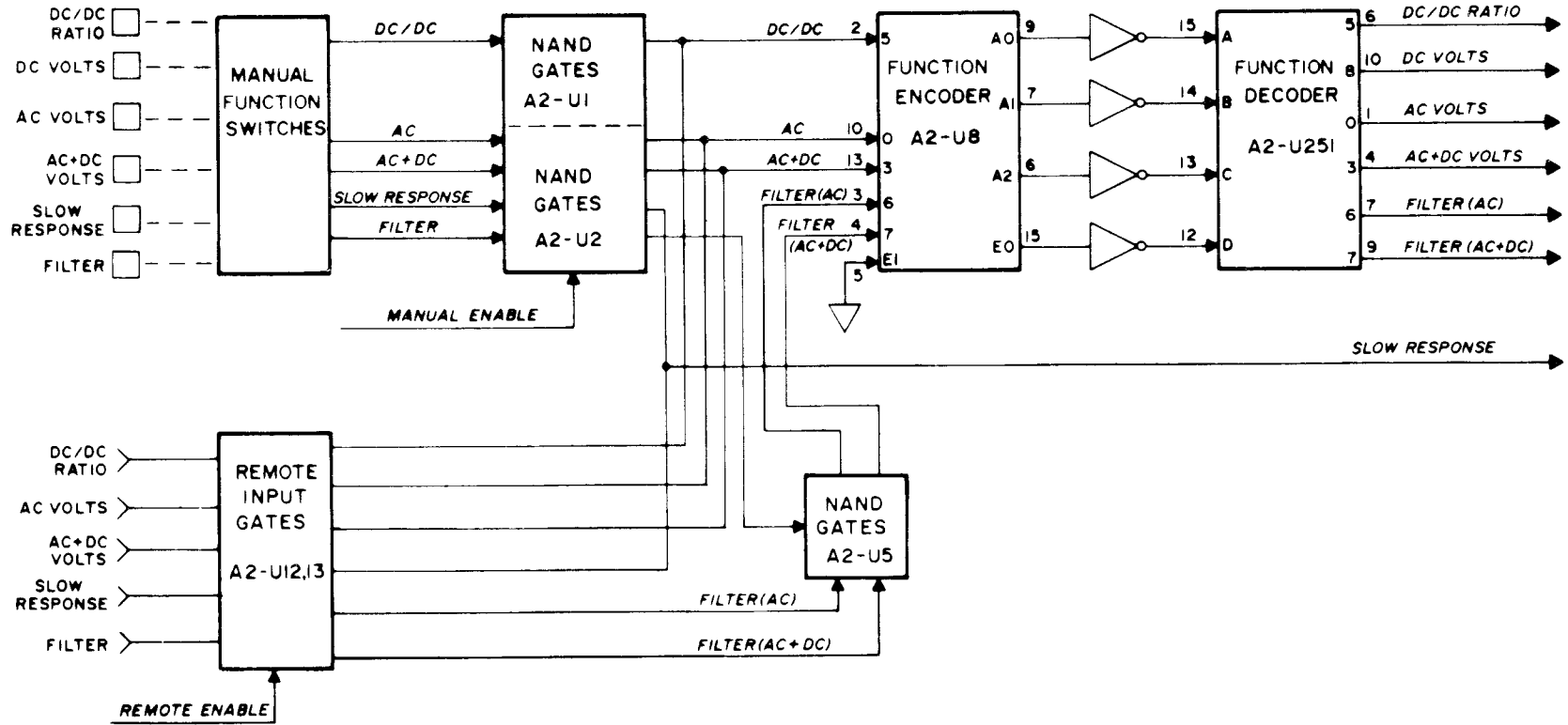

EL6UZ018

Figure 5-2. Function Selection Diagram

Table 5-9. Function Select Logic, A1-U251

Function	Inputs				Output									
	A	B	C	D	0	1	2	3	4	5	6	7	8	9
	Pin No.				Pin No.									
	15	14	13	12	1	2	3	4	5	6	7	9	10	11
DC/DC RATIO	H	L	H	L	H	H	H	H	H	L	H	H	H	H
DC VOLTS	L	L	L	H	H	H	H	H	H	H	H	H	L	H
AC VOLTS	L	L	L	L	L	H	H	H	H	H	H	H	H	H
AC+DC VOLTS	H	H	L	L	H	H	H	L	H	H	H	H	H	H
FILTER (AC)	L	H	H	L	H	H	H	H	H	H	L	H	H	H
FILTER(AC+DC)	H	H	H	L	H	H	H	H	H	H	H	L	H	H

L = 0 V; H = +5 V

5-22. Timing Waveforms

Figure 5-3 presents the timing relationships between the various pulses required to complete a measurement cycle. The condition chosen is

that for a full scale input signal measurement (maximum reference integration). This information is helpful in diagnosing problems that occur between the A/D Converter and Digital Counters.

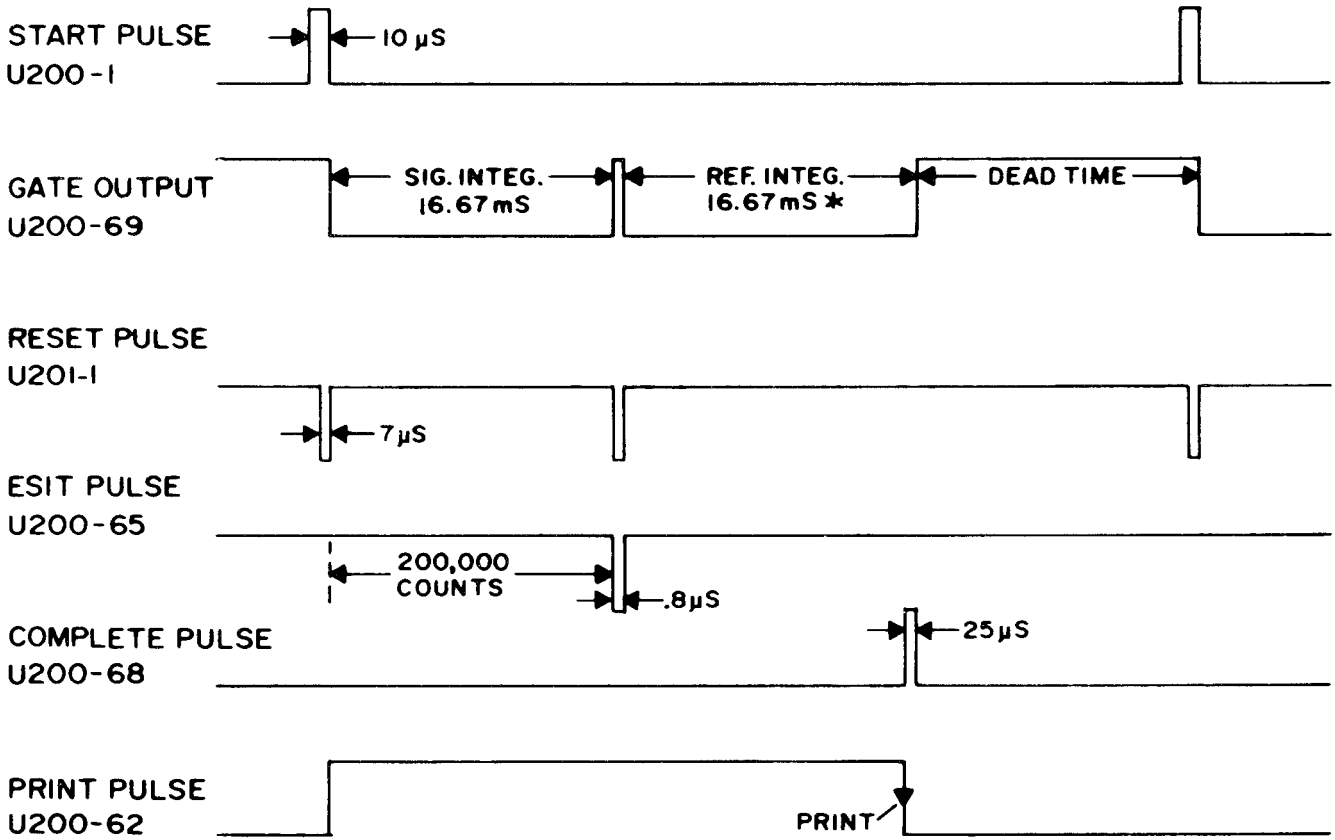

* FOR FULL SCALE READING

EL6UZ019

Figure 5-3. Timing Waveforms

CHAPTER 6

DIRECT SUPPORT AND GENERAL SUPPORT MAINTENANCE

Section I. GENERAL

6-1. Introduction

This section contains power supply voltage checks as well as information regarding the location of sub-assemblies, connectors and test points. See Figure 6-1 for the location of test points. Figure 6-2 shows the location of assemblies and figure 6-3 shows the location of the internal connectors.

6-2. Tools and Test Equipment

Section II contains information regarding the tools and test equipment required for direct sup-

port and general support maintenance of the voltmeter. Section III provides troubleshooting information in the form of flow charts.

6-3. Schematic Diagrams

Figures FO-2 through FO-14 are schematic diagrams covering all circuitry in the voltmeter. These schematics are separated into the major functions and/or assemblies and are arranged to follow the orderly flow of signals. All the schematic diagrams are located at the rear of this manual.

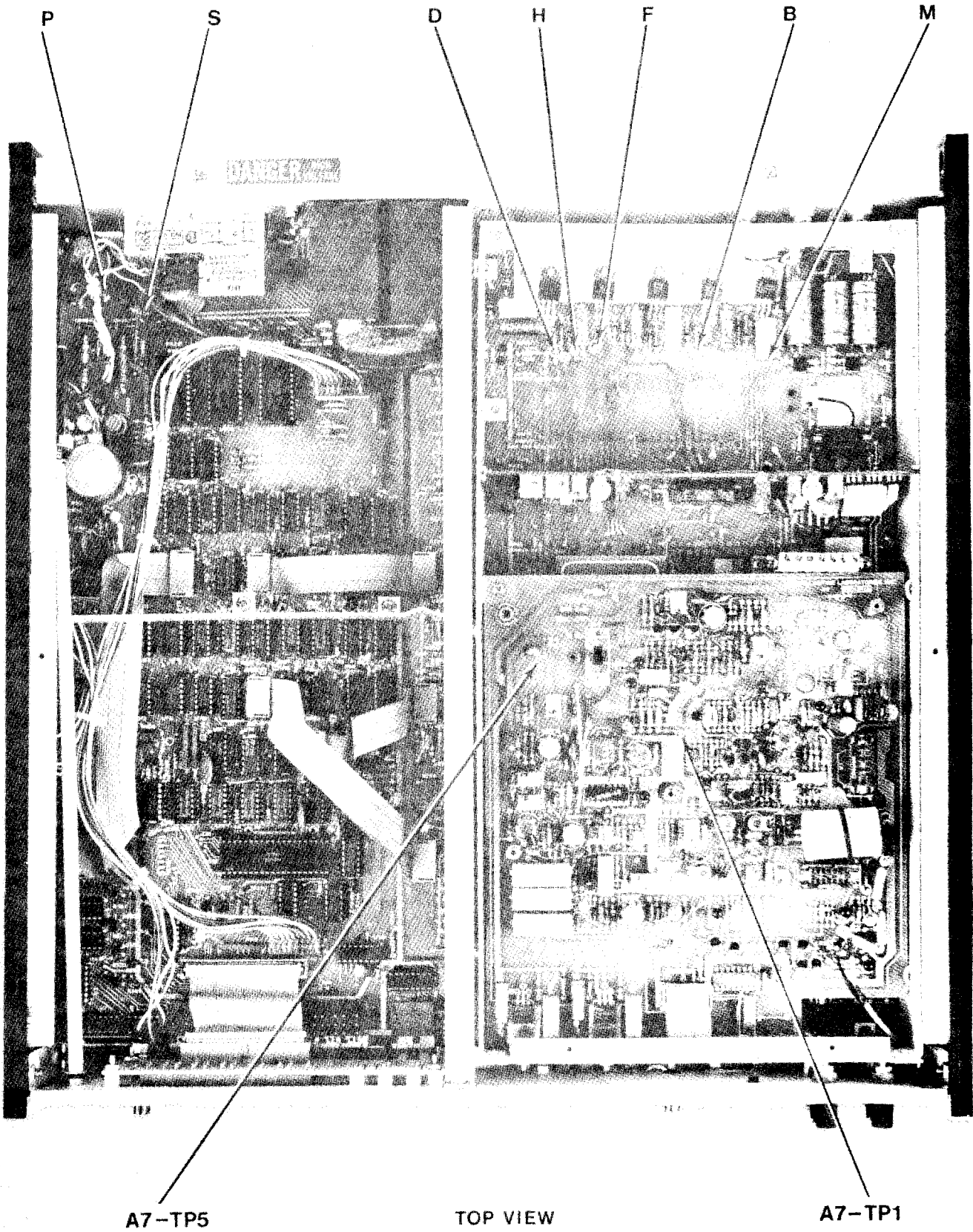

Figure 6-1. Location of Test Points

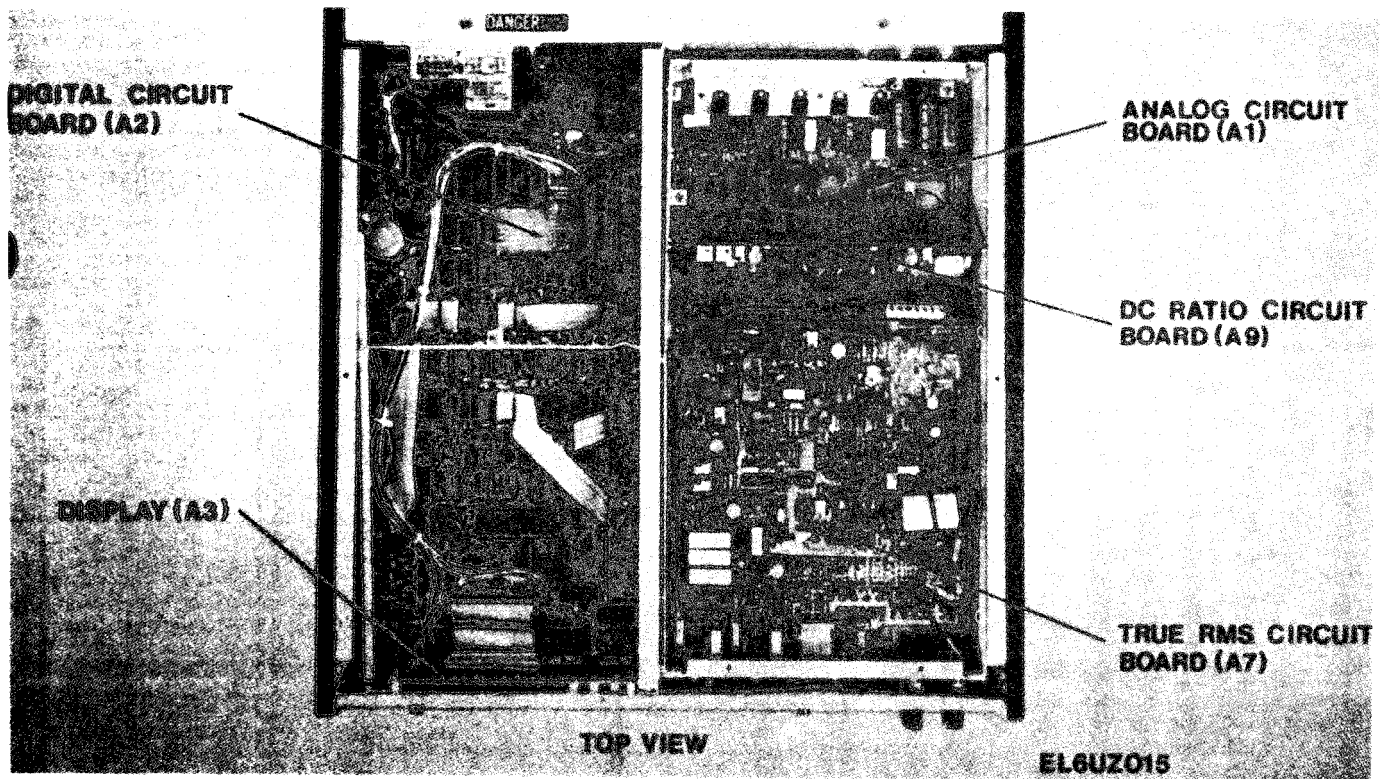

Figure 6-2. Location of Adjustments

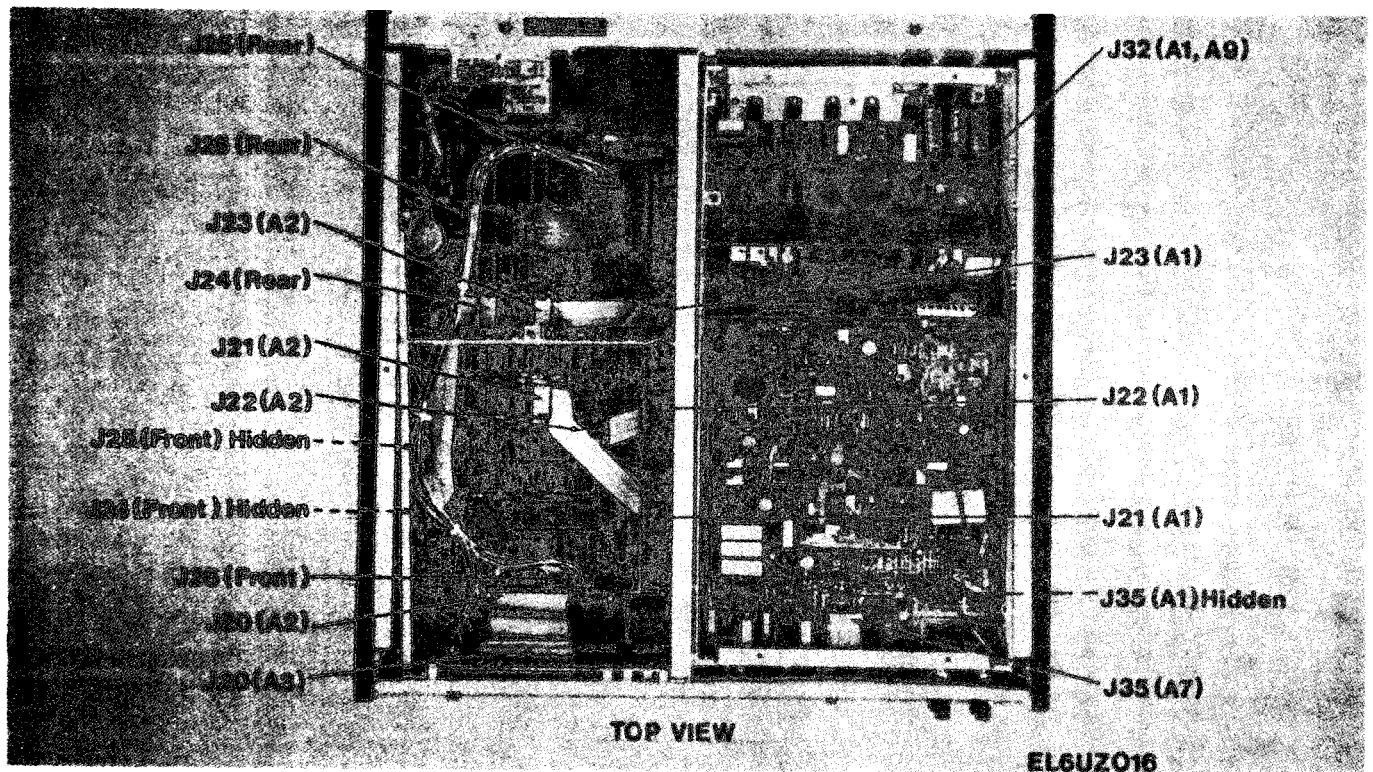

Figure 6-3. Location of Connectors

Section II. TOOLS AND TEST EQUIPMENT

6-4. Tools and Test Equipment Required

required for maintenance of the voltmeter (see table 6-1). No special tools are required.

This section contains a listing of test equipment

Table 6-1. Required Test Equipment

Nomenclature	Common Name	NSN	Reference Paragraph
John Fluke Model 332B	Dc voltage calibrator	6625-00-150-6994	6-14
John Fluke Model 5200A/5215A	Ac voltage calibrator	6625-01-063-6325	6-14
H.P. Model 180D	Oscilloscope	6625-00-022-8228	5-21
Gen. Rad. W10MT3AS3	Variable transformer	6120-00-168-3705	
AN/USM-451	Multimeter	6625-01-060-6804	6-7
CP-772 A/U	Frequency counter	6625-00-973-4837	

Section III. TROUBLESHOOTING

6-5. General

Troubleshooting information supplied in this section is in the form of flow charts that will facilitate locating a defective assembly or component rapidly.

First check for loose plug-in assemblies, improperly mated connectors, (figures 6-2 and 6-3) broken wires, physically damaged (burned or broken) components and other obvious problems. Next, the characteristics detailed in the Performance Assurance Checks of Section V (beginning with paragraph 6-13) should be checked and any discrepancies noted. This will serve as an aid to pin-pointing the source of trouble.

6-6. Fault Isolation

The voltmeter consists of the following major sections (also see Maintenance Allocation Chart:

- (a) Power Supply (A1, A2)

- (b) Dc Volts Attenuator/Buffer (A1)
- (c) A/D Converter (A1)
- (d) Up/Down Detector (A1)
- (e) Function Select Logic (A2)
- (f) Range Select Logic (A2)
- (g) Digital Counter/Display Drivers (A2)
- (h) Autorange Circuits (A2)
- (i) Clock Circuits (A2)
- (j) Display (A3)
- (k) True Rms Converter (A7)
- (l) Dc Ratio Amplifier (A9)

With the aid of the flow charts, figure 6-4 to 6-7, it should be possible to isolate the fault to one of these sections. Once the problem has been reduced to a major section, refer to the applicable schematic(s), figures FO-2 through FO-14, at the back of this manual to further isolate to the component level. Also refer to the logic tables in Chapter 5, Section II.

6-7. Power Supply Checks

Proper operation of the power supply is assured by measuring the various power supply

voltages listed in Table 6-2 and verifying that each voltage is within the specified tolerance. Refer to figure 6-1 for the location of voltage test points.

Table 6-2. Power Supply Voltage Measurements*

Voltage Regulator	Test Point	Voltage	Tolerance
* U950	S	+ 5 V	± .35 V
* U951	P	+ 5 V	± .35 V
U900	H	+ 15 V	± 1.0 V
U901	F	- 15 V	± 1.0 V
U902	M	+ 5 V	± .35 V
U903	D	+ 12 V	± .9 V
U904	B	- 12 V	± .9 V

* These measurements are referenced to digital ground (↓). All other voltages are referenced to analog ground (↗).

NOTE

When making measurements with a voltmeter or oscilloscope, keep in mind that there are two separate ground references; analog and digital ground. The A1 assemblies referenced to analog ground (↗) and the A2 assembly is referenced to chassis and digital ground (↓).

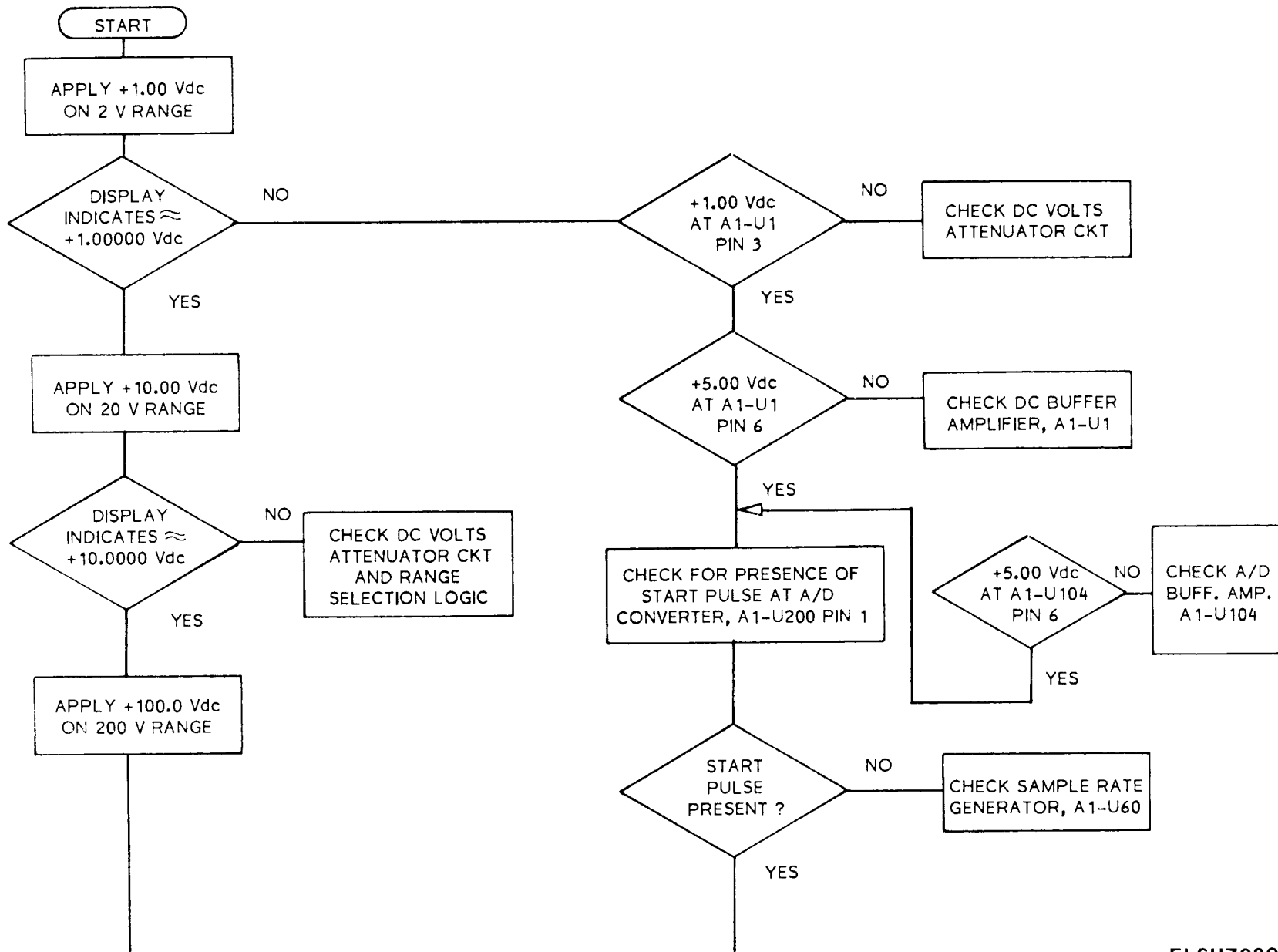

EL6UZ020

Figure 6-4. Troubleshooting Flow Chart, Dc Voltage (Sheet 1 of 5)

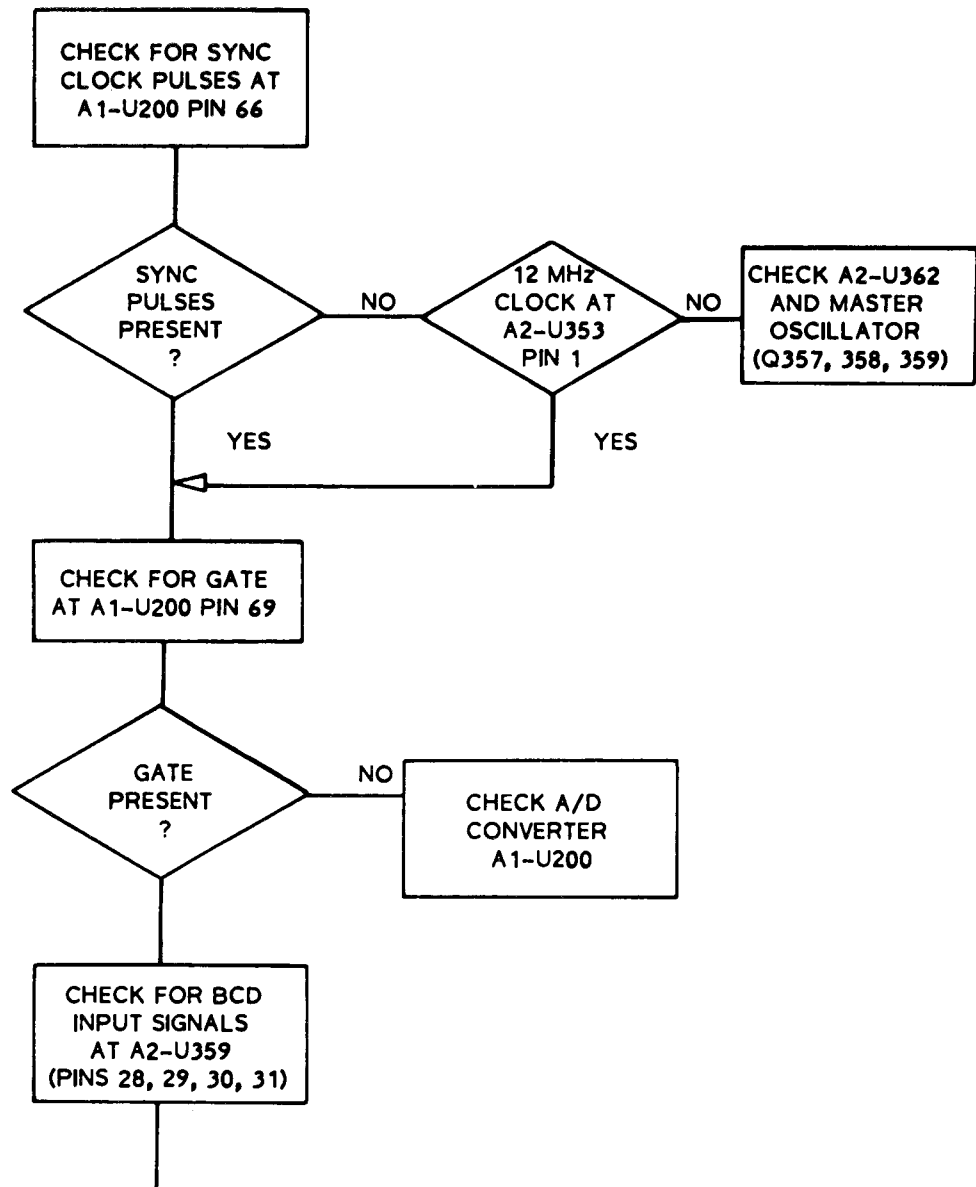
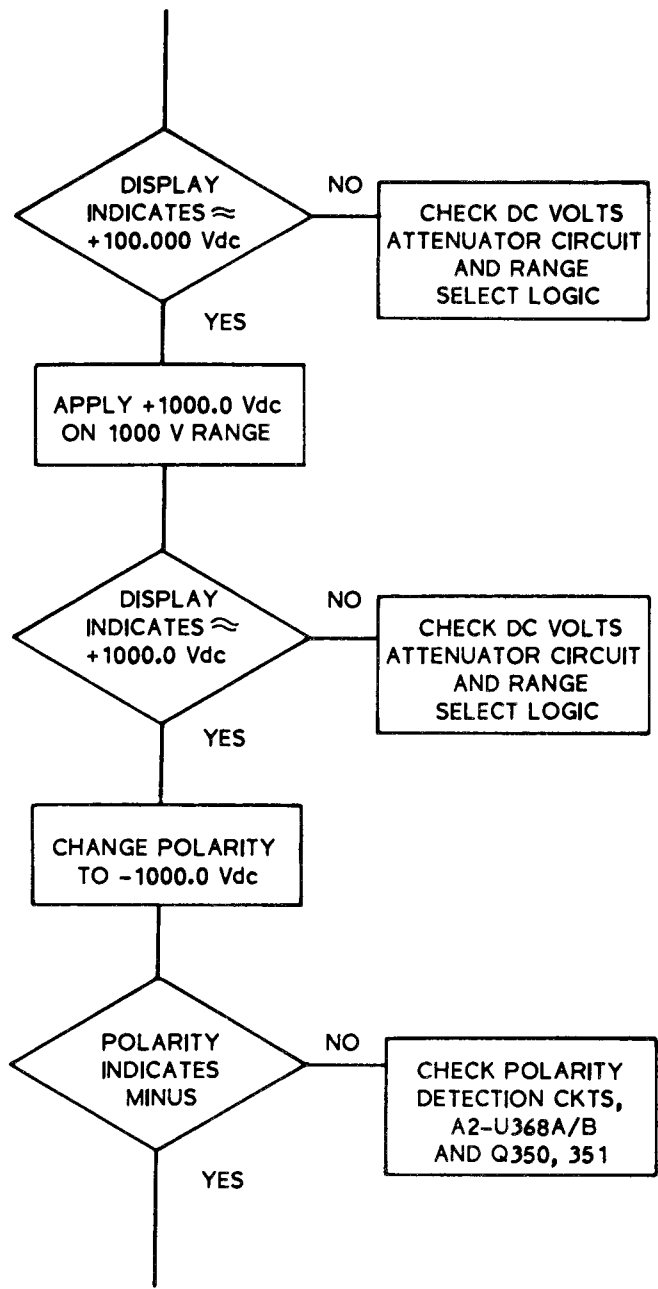
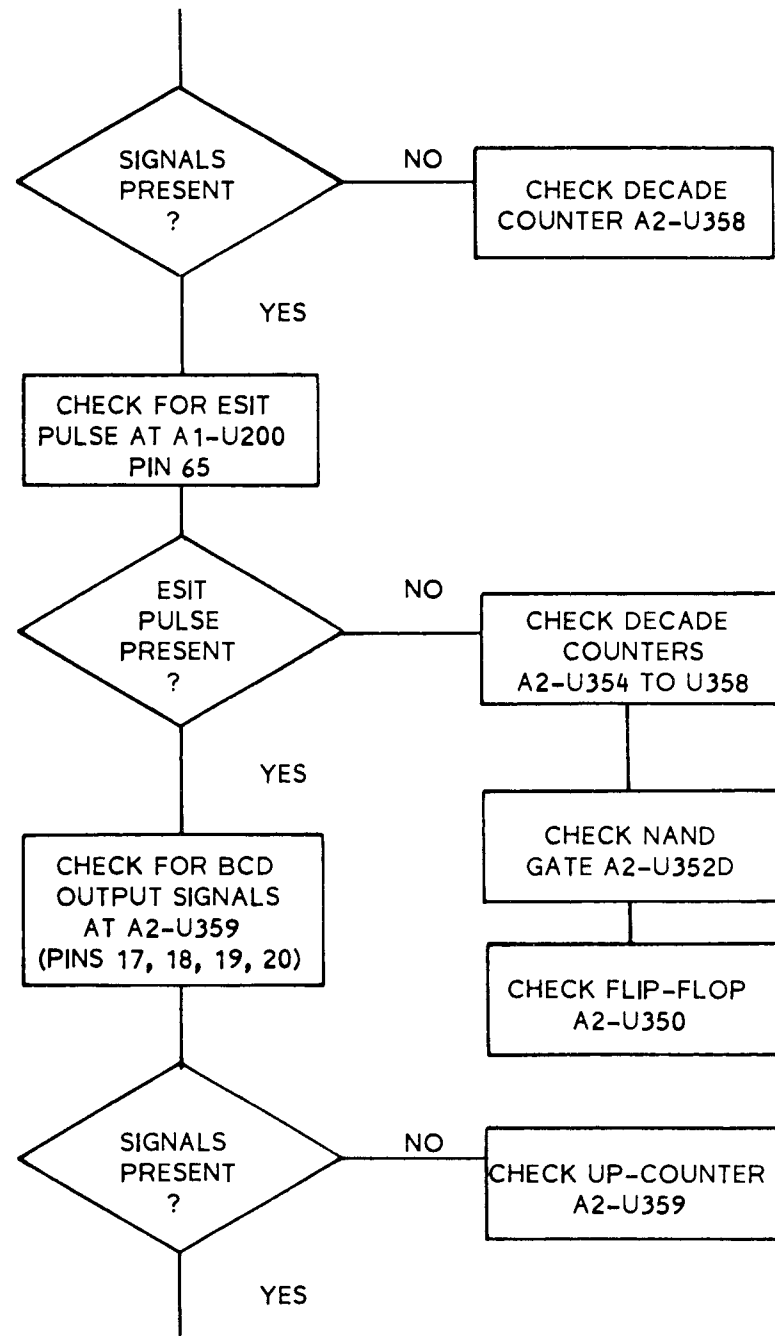

Figure 6-4. Troubleshooting Flow Chart, Dc Voltage (Sheet 2 of 5)

MANUAL DC VOLTAGE
OPERATION NORMAL



EL6UZ020

Figure 6-4. Troubleshooting Flip-Flop Chart, Dc Voltage (Sheet 3 of 5)

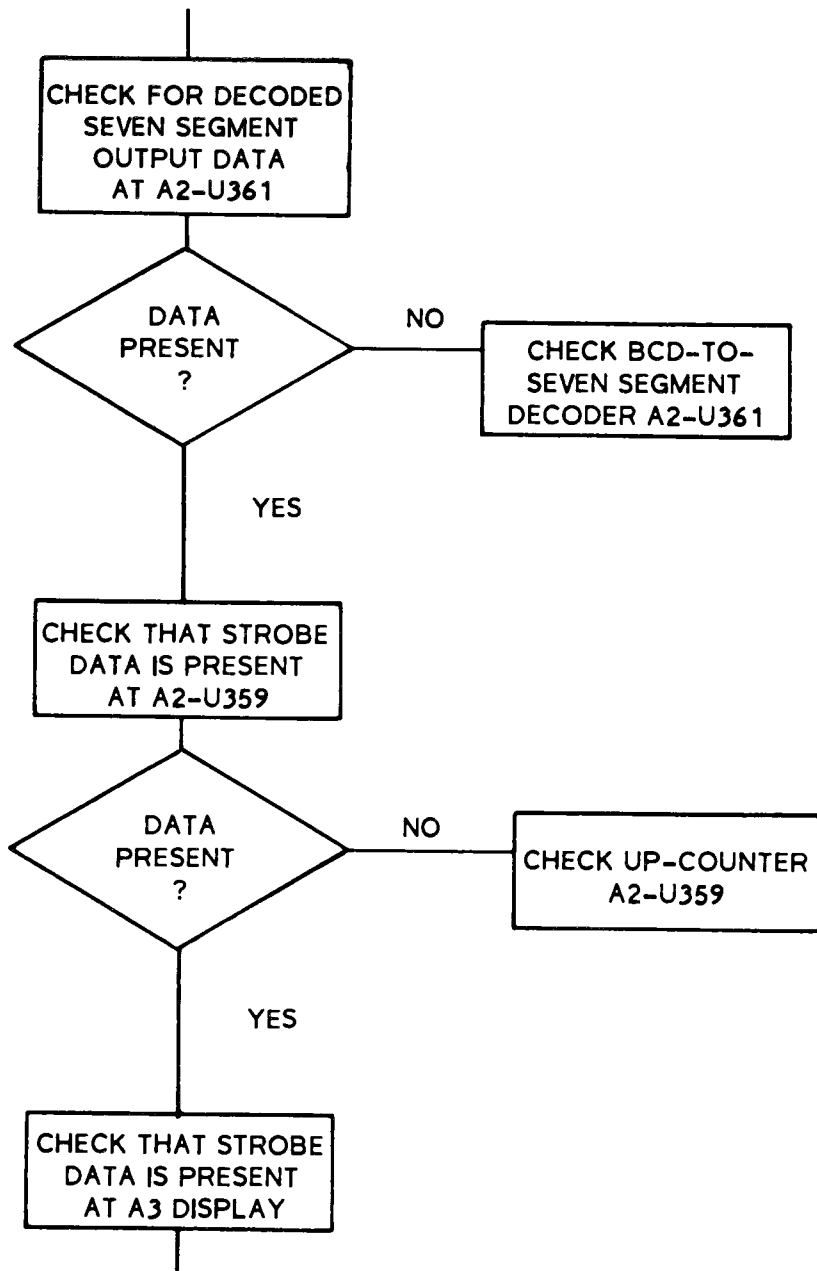

EL6UZ020

Figure 6-4. Troubleshooting Flow Chart, Dc Voltage (Sheet 4 of 5)

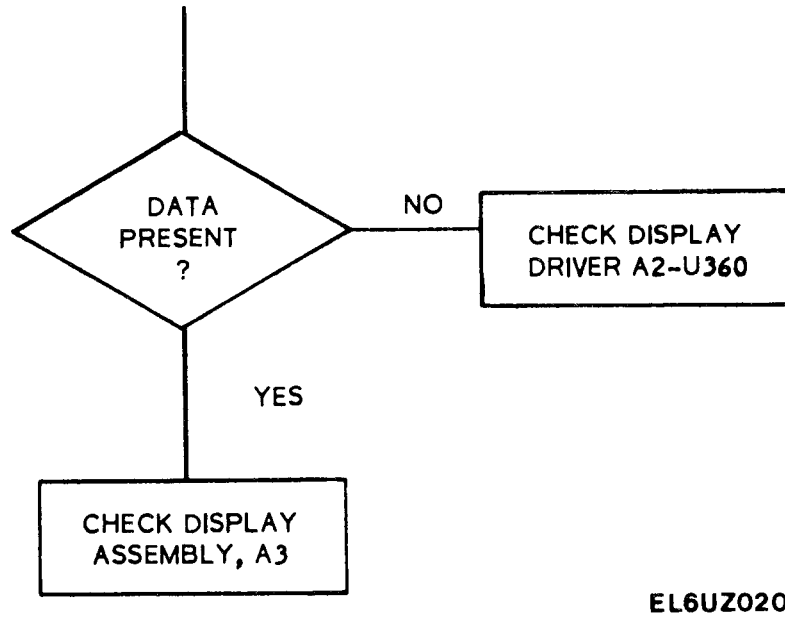

EL6UZ020

Figure 6-4. Troubleshooting Flow Chart, Dc Voltage (Sheet 5 of 5)

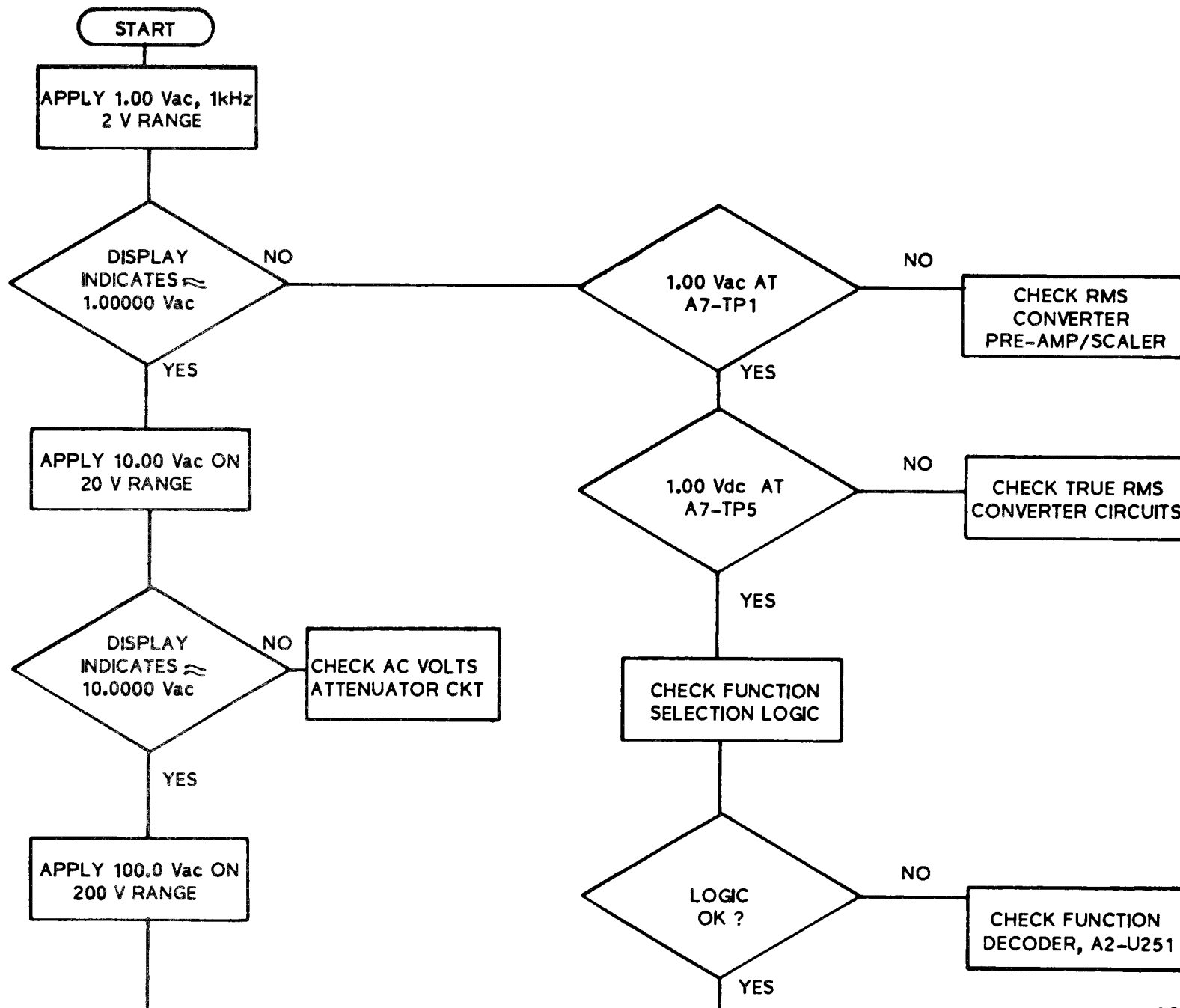
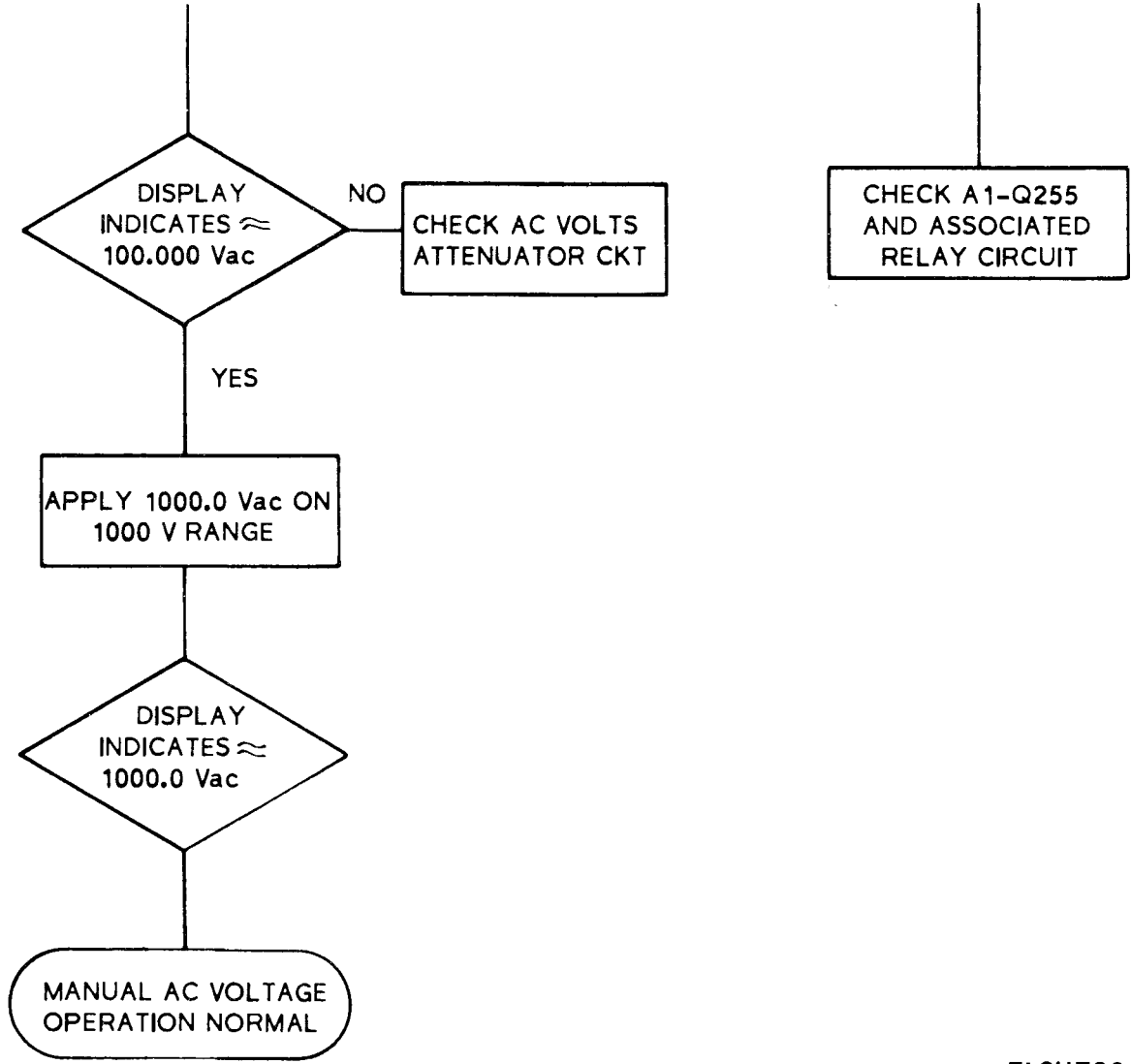

Figure 6-5. Troubleshooting Flow Chart, Ac Voltage (Sheet 1 of 2)

EL6UZ021



EL6UZ021

Figure 6-5. Troubleshooting Flow Chart, Ac Voltage (Sheet 2 of 2)

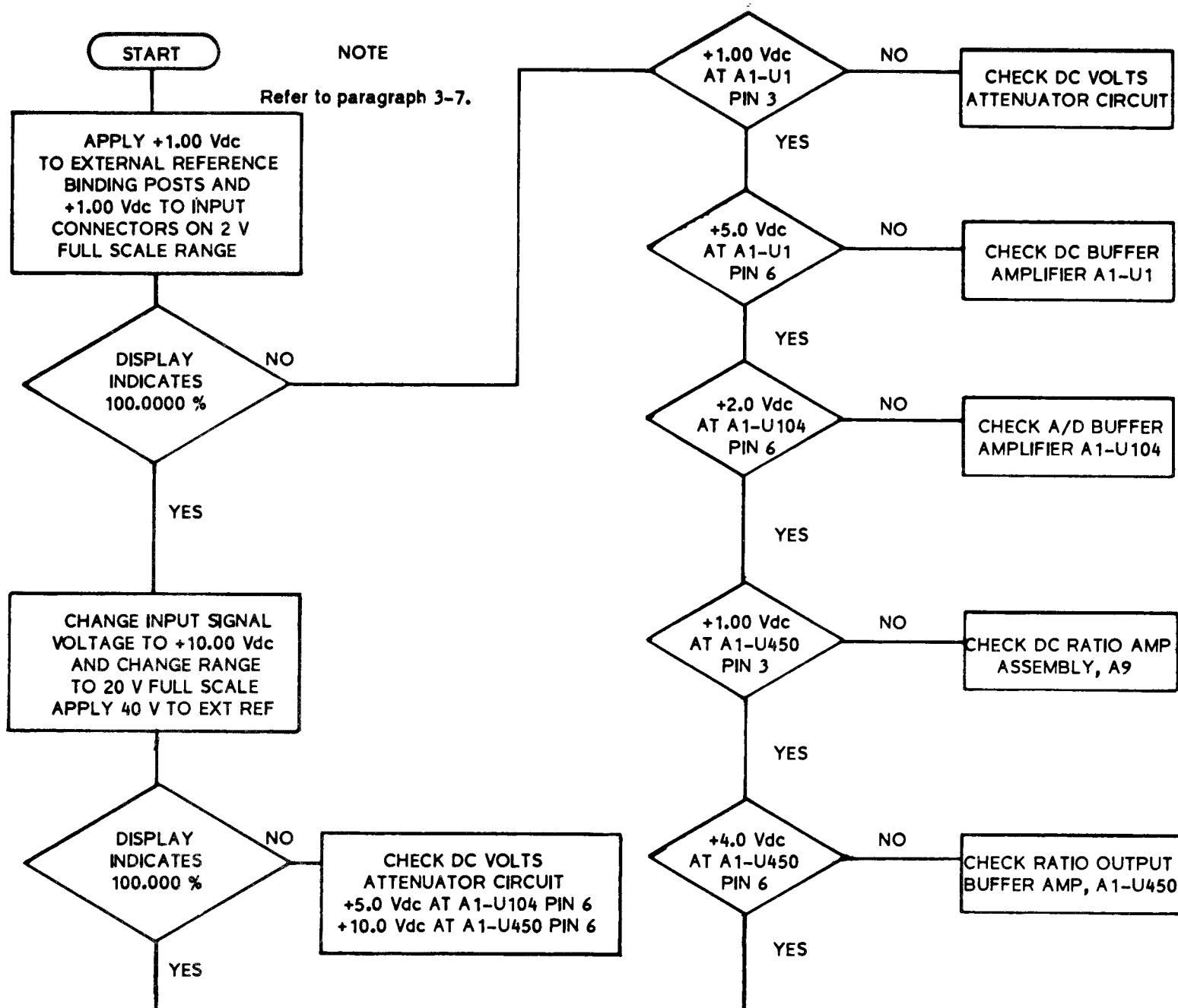
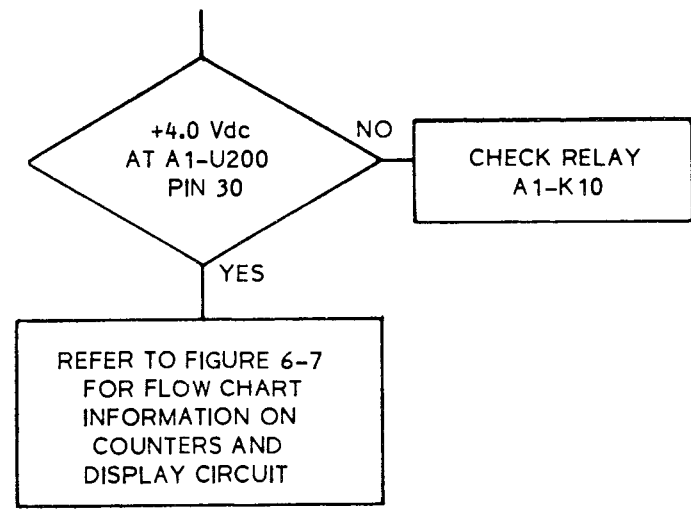
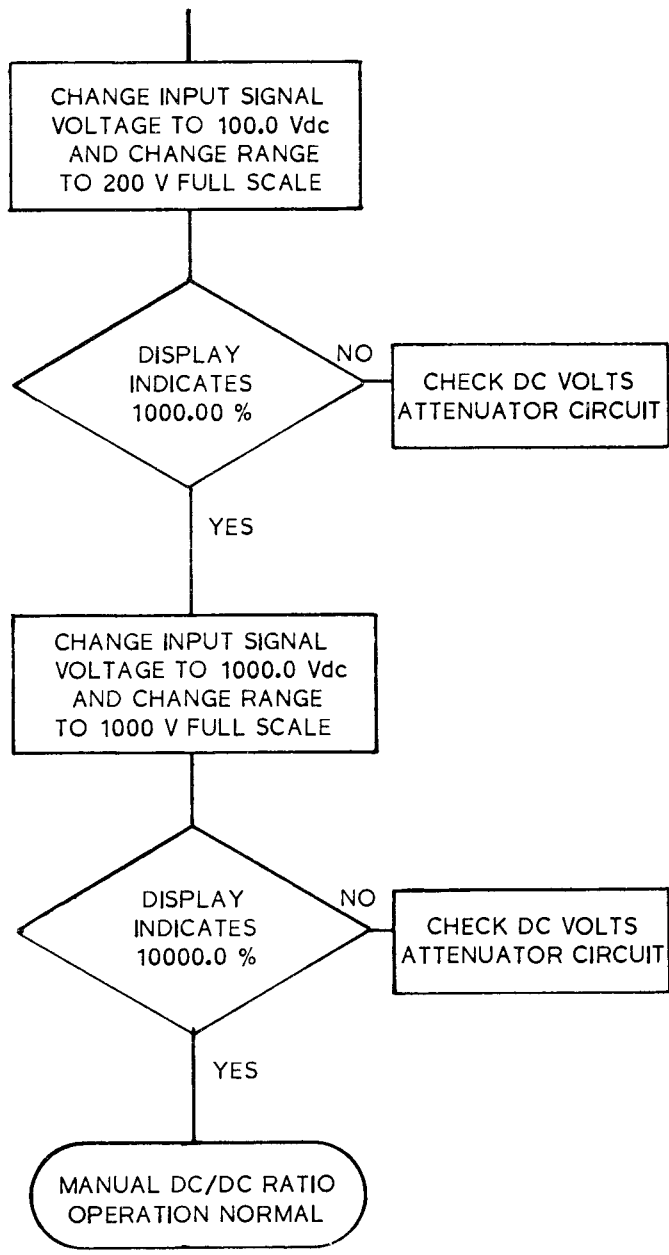

Figure 6-6. Troubleshooting Flow Chart, Dc/Dc Ratio (Sheet 1 of 2)

EL6UZ022



NOTE
Refer to paragraph 3-7.

EL6UZ022

Figure 6-6. Troubleshooting Flow Chart, Dc/Dc Ratio (Sheet 2 of 2)

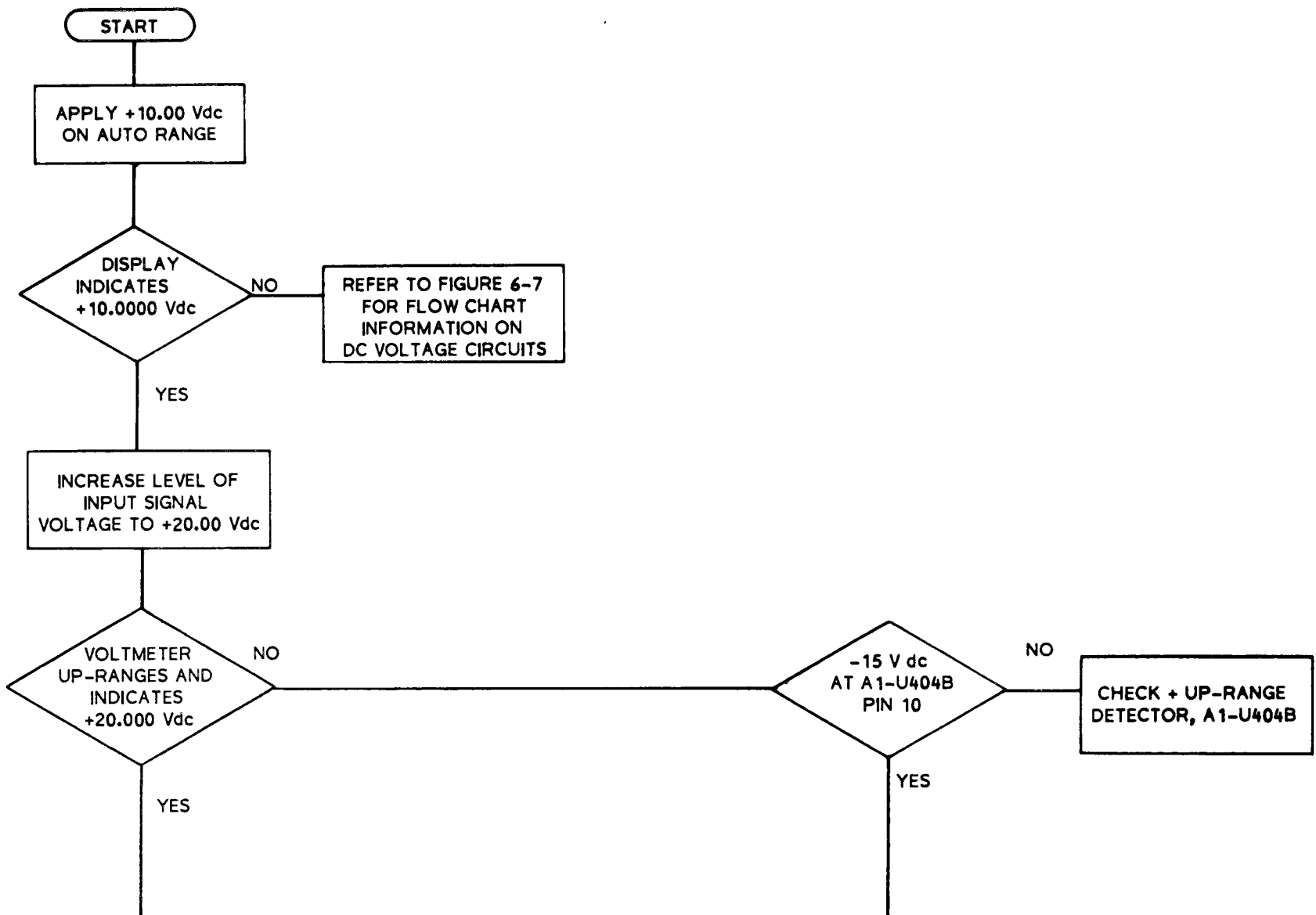

EL6UZ023

Figure 6-7. Troubleshooting Flow Chart, Auto Ranging (Sheet 1 of 4)

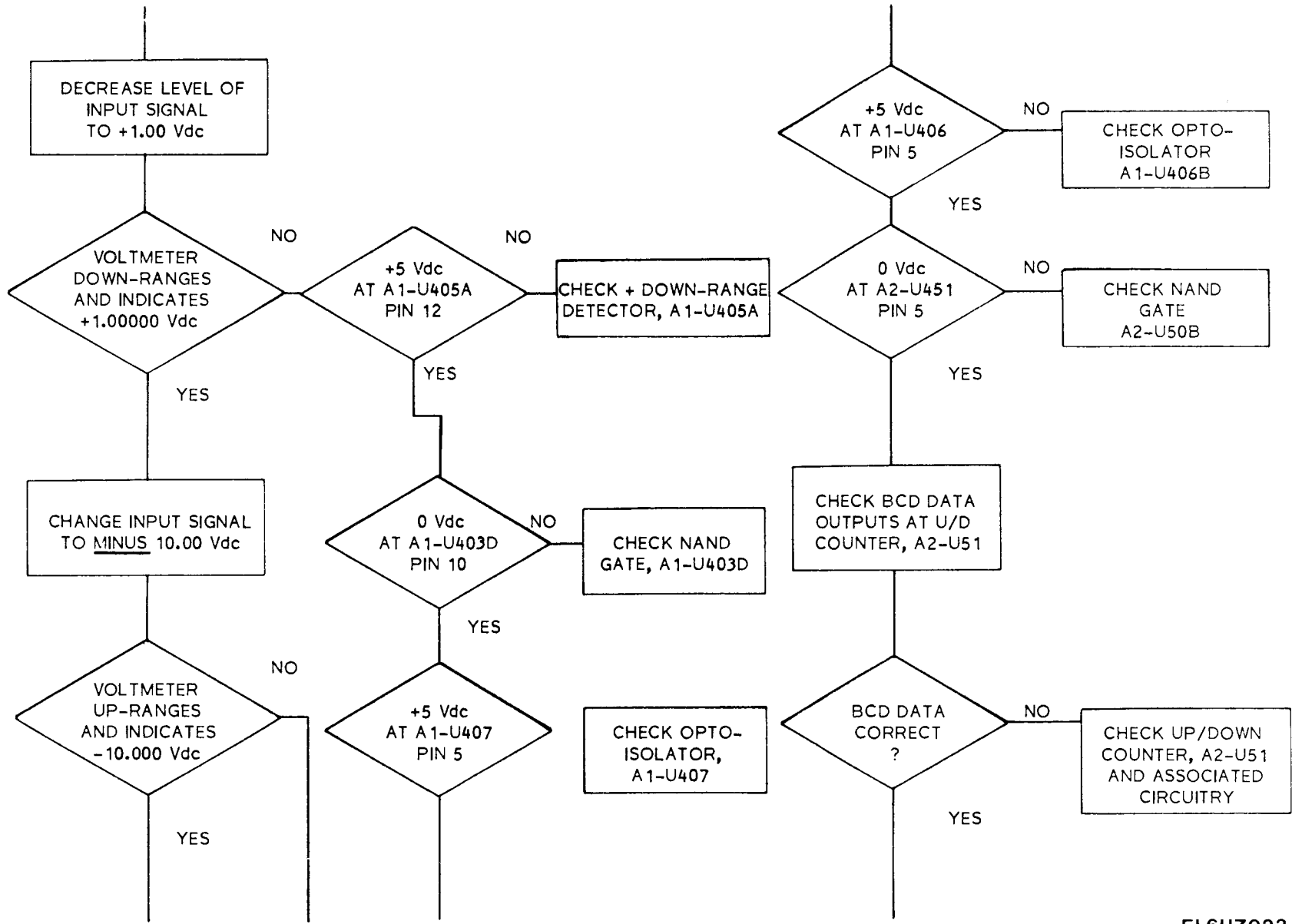

EL6UZ023

Figure 6-7. Troubleshooting Flow Chart, Auto Ranging (Sheet 2 of 4)

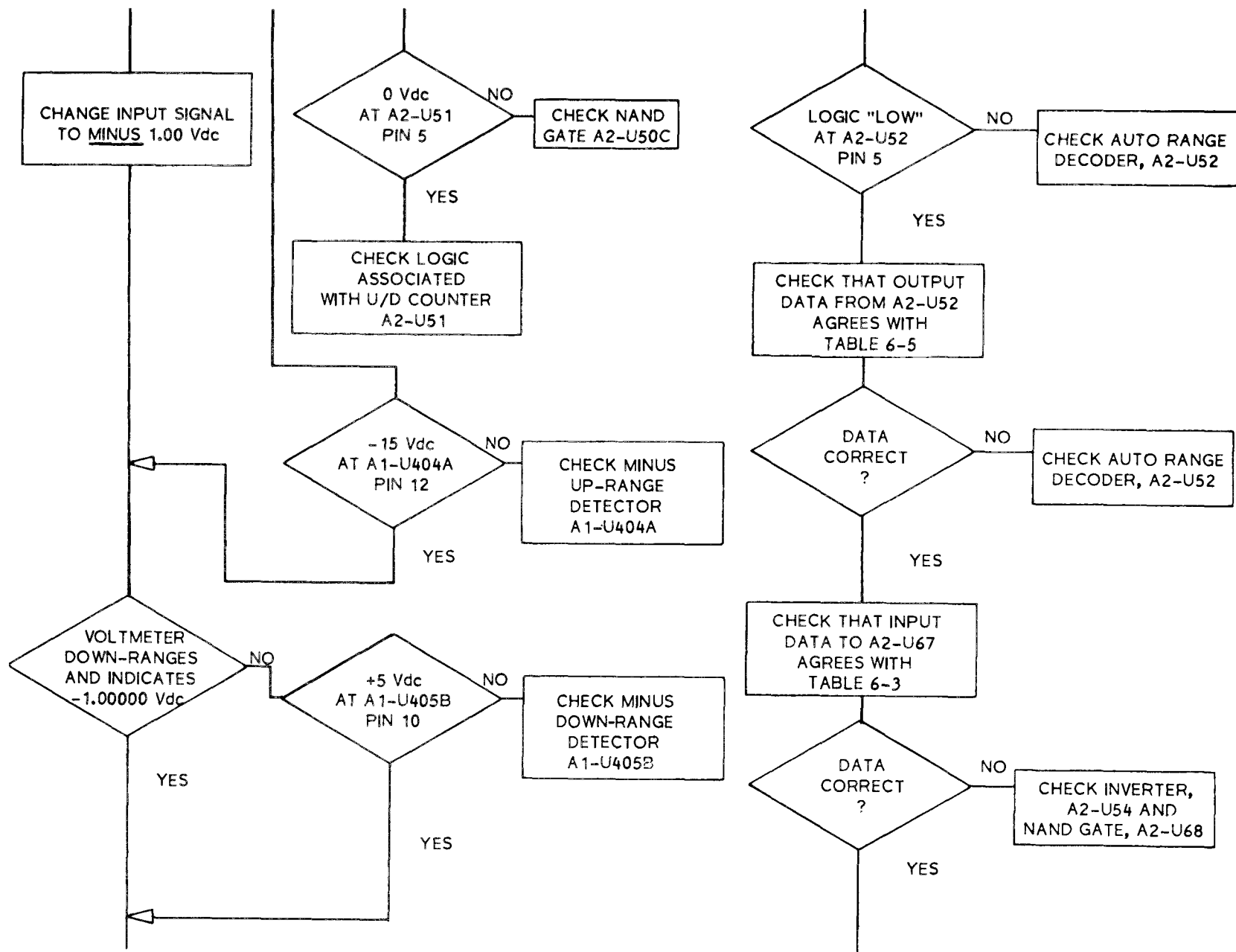

EL6UZ023

Figure 6-7. Troubleshooting Flow Chart. Auto Ranging (Sheet 3 of 4)

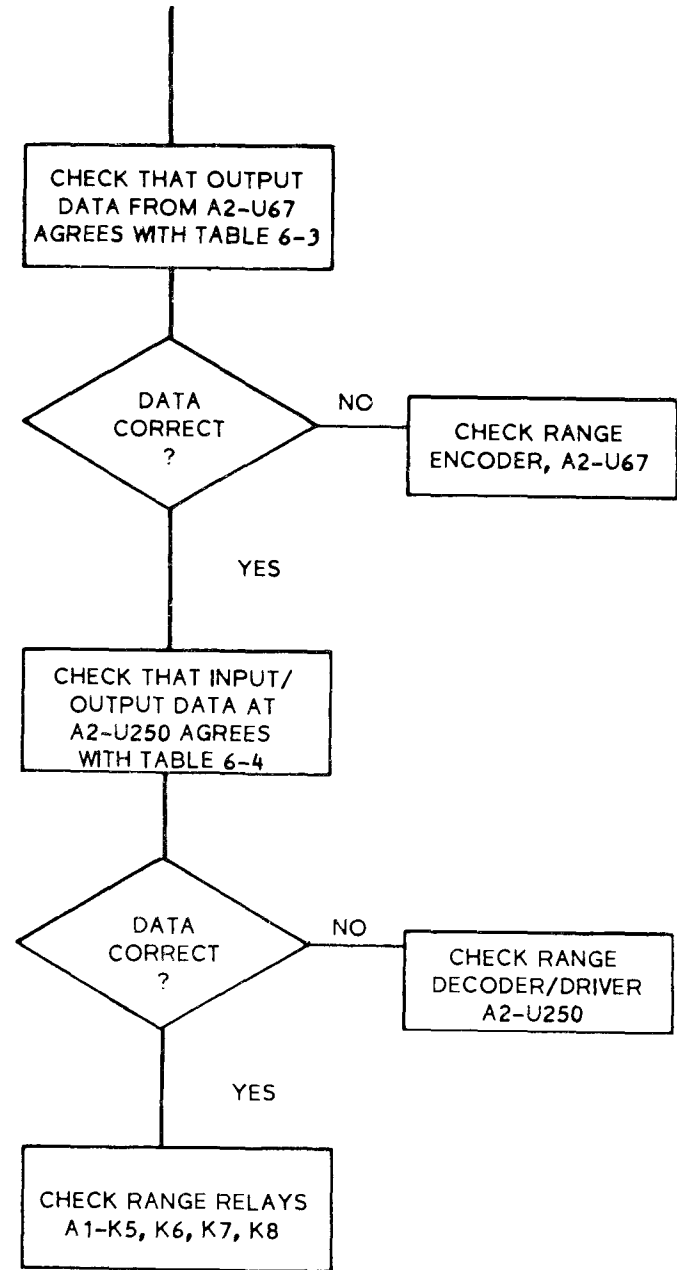
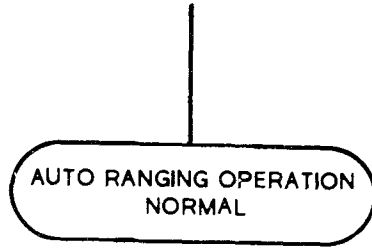

EL6UZ023

Figure 6-7. Troubleshooting Flow Chart, Auto Ranging (Sheet 4 of 4)

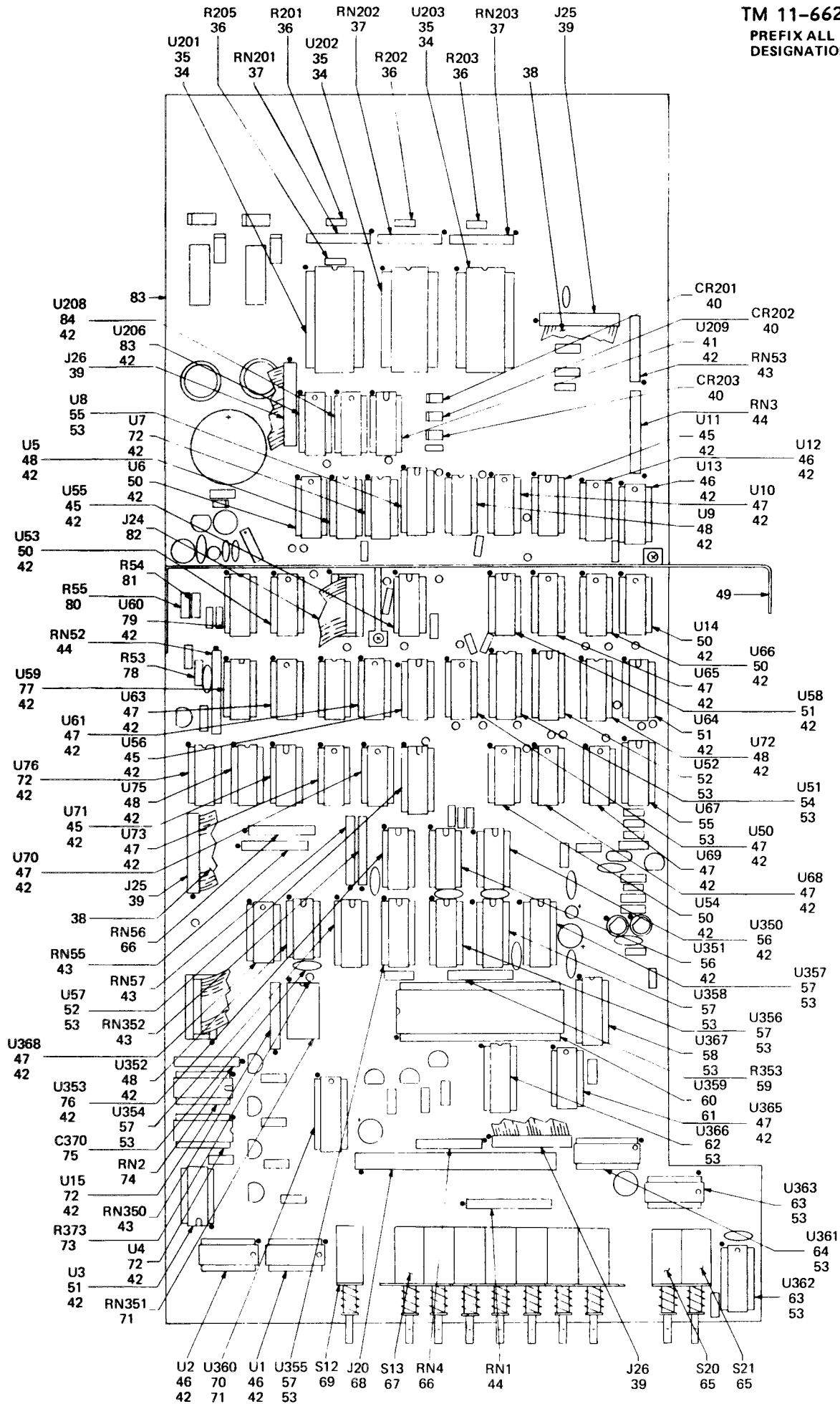
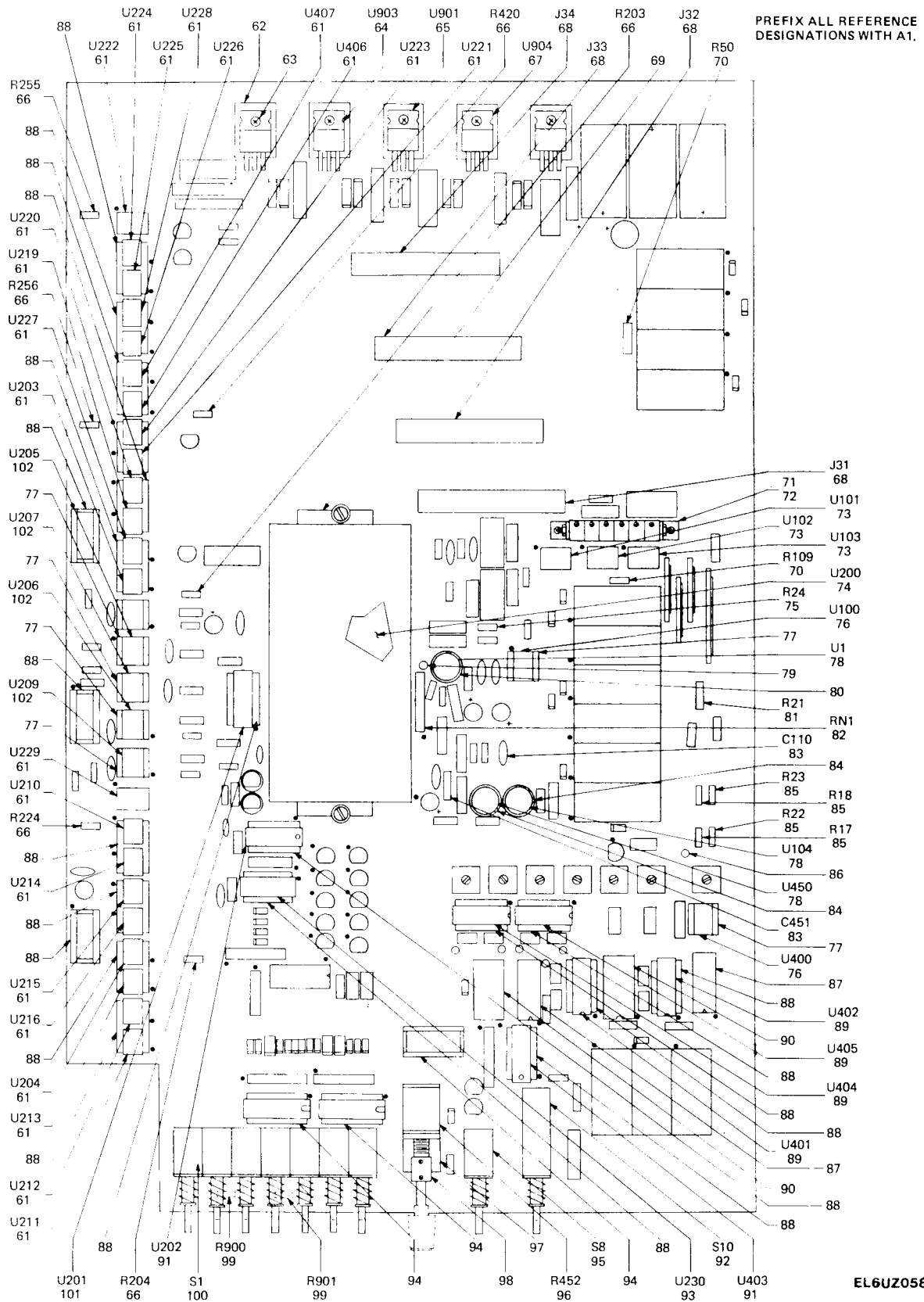

Figure 6-8. PCB, Digital Circuit Board



EL6UZ058

Figure 6-9. PCB, Analog Circuit Board

Section IV. MAINTENANCE OF THE VOLTMETER

6-8. General

This section contains maintenance instructions for the voltmeter. The information is arranged under paragraphs covering disassembly, cleaning, repair and replacement, assembly, and component selection. Contents of these paragraphs provide complete maintenance instructions for the voltmeter. The performance tests starting with paragraph 6-13 shall be conducted after any repairs are made.

CAUTION

No instructions for internal calibration are provided in this manual. Refer to TB11-6625-444-50-2. Do not disturb any internal adjustments when covers are removed.

6-9. Disassembly (See figure 6-10.)

WARNING

AC mains voltage connections are used within the voltmeter. Be careful when working on equipment if covers are removed and power cable is plugged into ac power outlet.

a. Top Dust Cover Removal

(1) Remove the top dust cover by first unscrewing the four 6-32 screws.

(2) Raise the cover slightly at the rear and then slide it forward far enough to clear the top flange of the front panel.

(3) Lift the top cover from the voltmeter.

b. Bottom Dust Cover Removal

(1) Turn the voltmeter upside down and remove the two 6-32 screws located at the rear of the dust cover that secure the rear feet. Remove the other two 6-32 screws retaining the sides of the cover.

(2) Raise the cover slightly at the rear and then slide it forward far enough to clear the bottom flange of the front panel.

(3) Lift the bottom cover from the voltmeter.

c. Top Guard Cage Cover Removal

(1) Unscrew the nine 4-40 screws securing the top guard cage covers. Two are located at the front of the cover, two are located at the rear and the remaining five unscrew from stand-offs mounted on the True Rms Converter assembly.

(2) Lift the cover plate and remove it from the voltmeter.

d. Bottom Guard Cage Cover Removal

(1) Turn the voltmeter upside down and unscrew the eight 4-40 screws securing the bottom guard cage cover.

(2) Lift the cover plate and remove it from the voltmeter.

e. True Rms Converter Board Assembly (A7) Removal

(1) Carefully unplug the center conductor lead (A7-R1) from terminal **(A)**. Refer to figure 6-11.

(2) Carefully unplug the shield lead (A7-R163) from terminal **(B)**. Refer to figure 6-11.

(3) Disconnect connector A7-J35.

(4) Unscrew the two 4-40 screws that secure the front mounting bracket to the front of the guard cage.

(5) Unscrew the 4-40 screw located at the rear left corner of the True Rms Converter board.

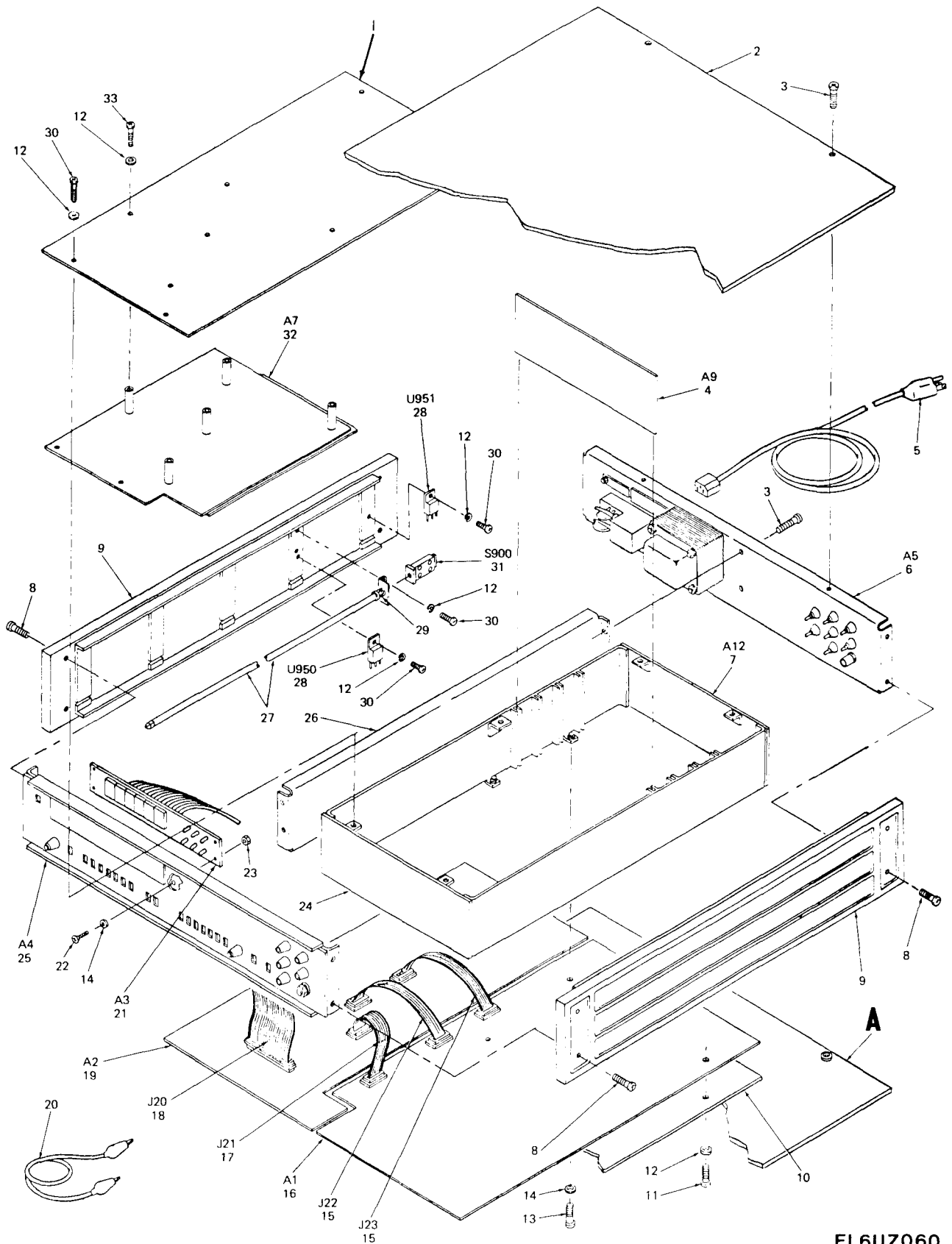

EL6UZ060

Figure 6-10. Digital Voltmeter AN/GSM-64C, Exploded View

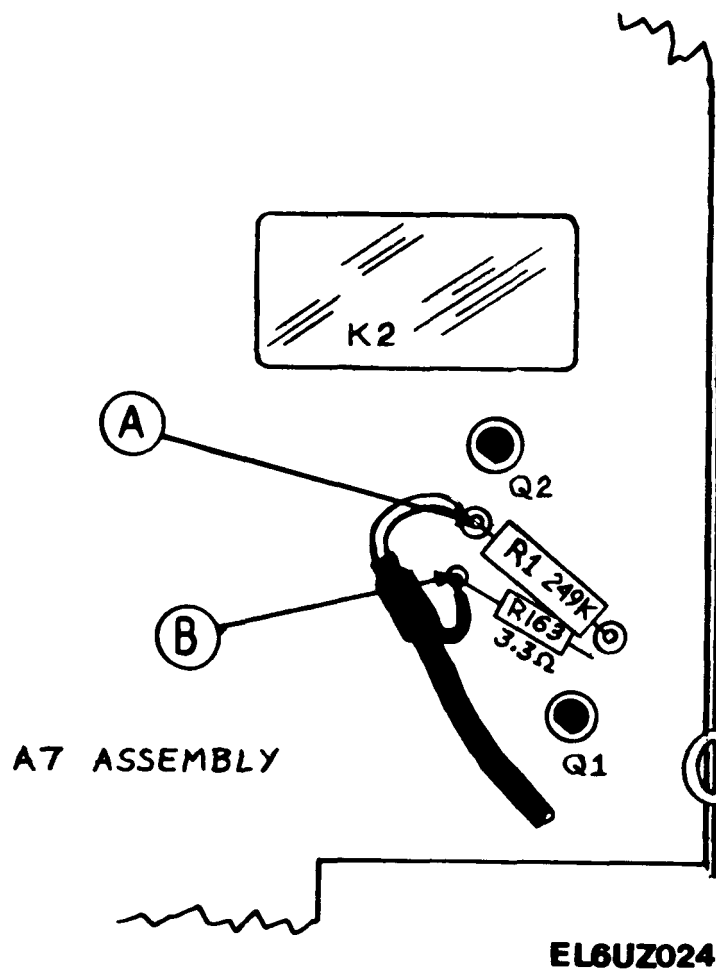

Figure 6-11. Rms Converter (A7) Signal Input Connections

(6) Move the True Rms Converter board slightly to the left to clear the rear support extrusion on the right side of the guard cage.

(7) After the board is free of the support extrusion, raise the back slightly and slide the assembly rearward so that the front mounting bracket clears the guard cage angle bracket.

(8) Lift the True Rms Converter board assembly up from the voltmeter.

f. True Rms Converter Guard Shield Removal

(1) Unscrew the five 4-40 screws securing the guard shield to the bottom of the True Rms Converter board.

(2) Remove the guard shield from the bottom of the board.

g. Dc Ratio Board (A9) Assembly Removal

Pull the Dc Ratio board straight up to unplug it from the connector A1-J32 and remove the assembly from the voltmeter.

h. Removal of Display Assembly (A3)

(1) Grasp the ribbon lead at the rear of the display assembly connector (A3-J20) at both sides with the thumb and forefinger of each hand and pull the connector free. This may require more than a moderate effort to free the connector.

(2) Using a nutdriver, unscrew the four 4-40 nuts holding the display assembly to the front panel.

(3) Move the assembly slightly rearward and free of the mounting studs; then lift it up from the voltmeter.

CAUTION

Be careful not to disturb the position of the backup nuts on the mounting studs. These “fix” the location of the digital display assembly with respect to the Plexiglas window.

6-10. Cleaning instructions, refer to paragraph 4-10.

6-11. Repair and Replacement

a. Input Connector Replacement. The input connectors (binding posts) on the front panel or rear panel of the voltmeter are replaced as follows (refer to figure 6-12):

Removal:

(1) Unsolder the lead from the binding post terminal (if required).

(2) Unscrew the nut from the binding post stud using a 5/16” open end wrench.

(3) Remove the binding post and its associated insulators and lockwasher from the panel.

Installation:

(4) Mount the replacement binding post, including its insulators and lockwasher, on the panel.

CAUTION

The binding post insulators are “keyed” and, with the exception of the CASE binding posts, mount in “D” shaped holes. Make sure that the insulators are oriented correctly before tightening the nut.

(5) Thread the nut onto the binding post stud and tighten it securely using a 5/16” open end wrench.

(6) solder the wire to the binding post terminal (if required).

b. General Component Replacement.

NOTE

Soldering shall be in accordance with MIL-HDBK-454A. A vacuum operated resoldering tool shall be used when-ever resoldering is required. Maximum allowance soldering iron wattage rating is 35 watts.

CAUTION

Use a “grounded” type soldering iron to avoid over voltage damage to integrated circuits and other voltage sensitive devices.

Whenever removing a component, provide a heat sink such as long-nose pliers, alligator clips; or use a commercial heat sink if one is available. The following steps are recommended for general component removal and replacement:

(1) Place the soldering iron directly on the component lead on the conductor side of the printed circuit board. Use the resoldering tool to remove all solder and free the component lead.

(2) Straighten the component leads with long-nose pliers and remove the component from the board.

(3) If a component is obviously faulty or damaged, clip the leads close to the body of the component then remove the remaining leads from the conductor side of the board.

(4) Use a short soldering time cycle since excessive or prolonged heat may destroy the laminate bond and lift the copper conductors from the circuit board; or cause either immediate degradation or latent damage of the components.

(5) Clean the component lead holes by heating the solder on the circuit board conductor pad, quickly removing the soldering iron, and

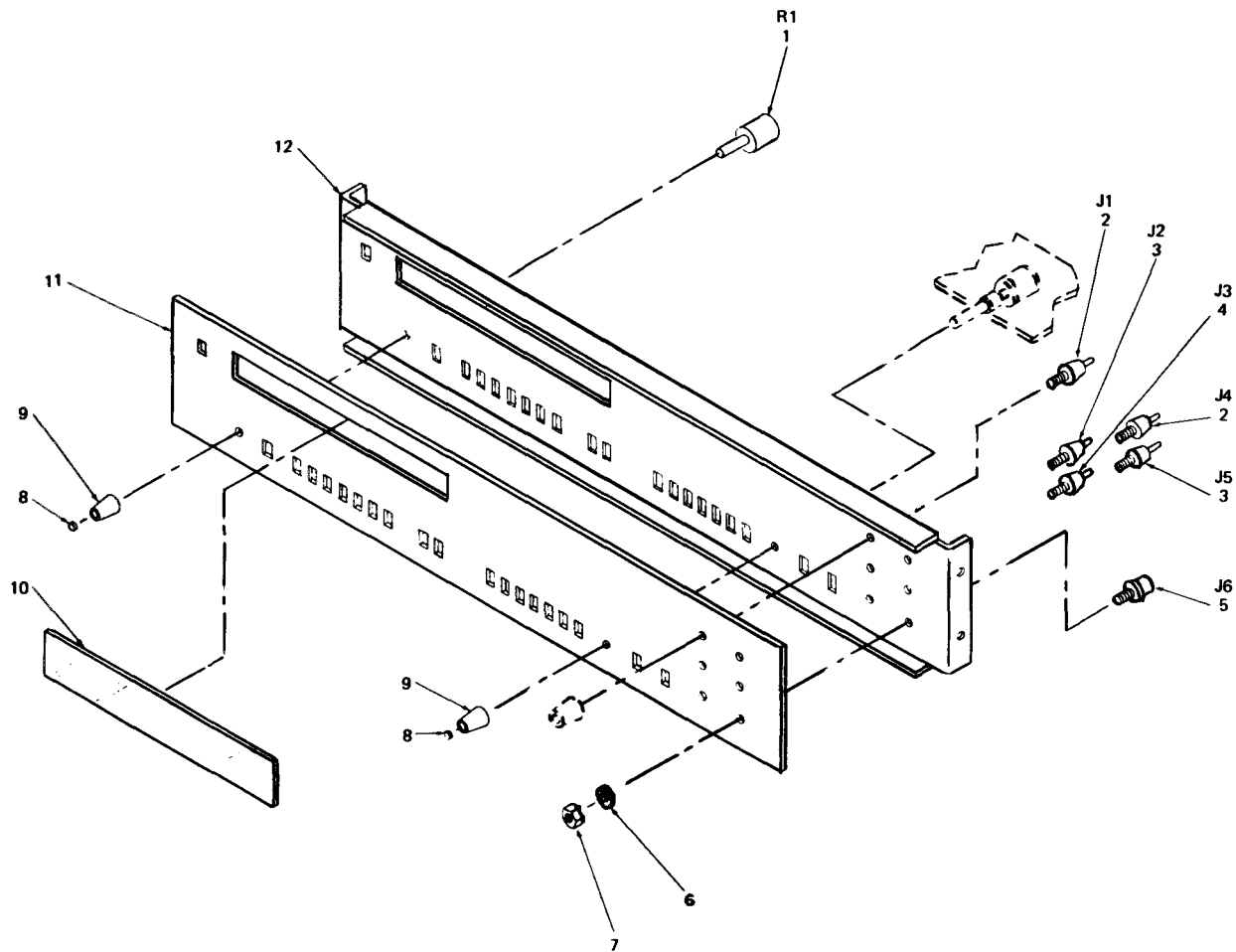

PREFIX ALL REFERENCE DESIGNATIONS WITH A4.

EL6UZ063

Figure 6-12. Digital Voltmeter AN/GSM-64C, Front Panel Assembly

inserting a pointed non-metallic object, such as a toothpick, to clean the hole. Do not allow solder to cover the hole since the new component leads may then push the pad away from the hole.

(6) To install a new component, first straighten and shape the leads then insert the component into the proper holes. Bend the leads on the conductor side of the circuit board so that they extend to the foil of the incoming conductor path. Cut the bent leads about 3/32 of an inch from the hole. Attach a heat sink to the lead near the body of the component. Heat both the lead and pad with the soldering iron. Apply solder as required to cover the lead and form a meniscus over the hole ensuring a good electrical connection.

(7) After replacing a component, clean excess flux from the connection and surrounding area using isopropyl alcohol.

6-12. Assembly

a. Display Assembly (A3)

(1) Remount the display assembly on the four mounting studs.

(2) Secure the assembly with the four 4-40 nuts. Tighten all four nuts using a nutdriver. Apply a small amount of Glyptol to all four nuts (also to any back up nuts that might have been accidentally disturbed) to insure that they will not loosen.

(3) Reconnect connector A3-J20 to the display board.

CAUTION

Be sure to insert the connector perpendicular to the display assembly board to prevent the bending or breaking of any of the male connector pins.

b. Dc Ratio Board (A9)

With the component side of the Dc Ratio board facing towards the front of the voltmeter, push the assembly snugly down into connector A1-J32.

NOTE

Make sure the left and right edges of the board are in the extruded guides as the board is inserted.

c. True Rms Converter Guard Shield

(1) Position the guard shield over the bottom of the True Rms Converter board so the holes align with the threaded spacers.

(2) Fasten the shield securely to the board assembly with the five 4-40 screws.

d. True Rms Converter Board Assembly (A7)

(1) Make sure that the ribbon lead connector and coax cable are dressed in front of and over the top of the board assembly. Tilt the assembly slightly towards the front of the voltmeter in order to clear the guard cage angle bracket.

(2) Apply moderate pressure to the right side of the guard cage to bow it slightly and permit entry of the right edge of the board into the two extruded supports.

(3) Fasten the front mounting bracket to the front of the guard cage with two 4-40 screws. Do not tighten any of the mounting screws securely at this time.

(4) Fasten the rear left corner of the board to the angle bracket with a 4-40 screw.

(5) Position the True Rms Converter board so that the AC NULL control, A7-R23, aligns with the adjustment hole in the front panel and then tighten all three mounting screws securely.

(6) Re-connect the ribbon lead connector to A7-J35.

(7) Plug the shield lead to terminal **(B)**. See figure 6-11.

(8) Plug the center conductor to terminal **(A)**. See figure 6-11.

e. Bottom Guard Cage Cover

(1) Turn the voltmeter upside down and position the bottom guard cage cover so that the mounting holes align with the threaded spacers.

(2) Fasten the cover securely with eight 4-40 screws.

f. Top Guard Cage Cover

(1) Place the top guard cage cover over the guard cage so the mounting holes align with the five threaded spacers and four mounting brackets.

(2) Fasten the cover securely with nine 4-40 screws.

g. Bottom Dust Cover

(1) Turn the voltmeter upside down and orient the bottom dust cover so the curved cover

lip is towards the front of the voltmeter.

(2) Hook the curved lip over the front of the panel flange; laying the cover rearward and down.

(3) Fasten the bottom dust cover by inserting the two 6-32 screws through the rear feet and into the threaded chassis holes and then fasten the other two 6-32 screws to retain the sides of the cover.

h. Top Dust Cover

(1) Orient the top dust cover so the curved cover lip is towards the the front of the voltmeter.

(2) Hook the curved lip over the front panel flange; laying the cover rearward and down.

(3) Fasten the top dust cover with four 6-32 screws.

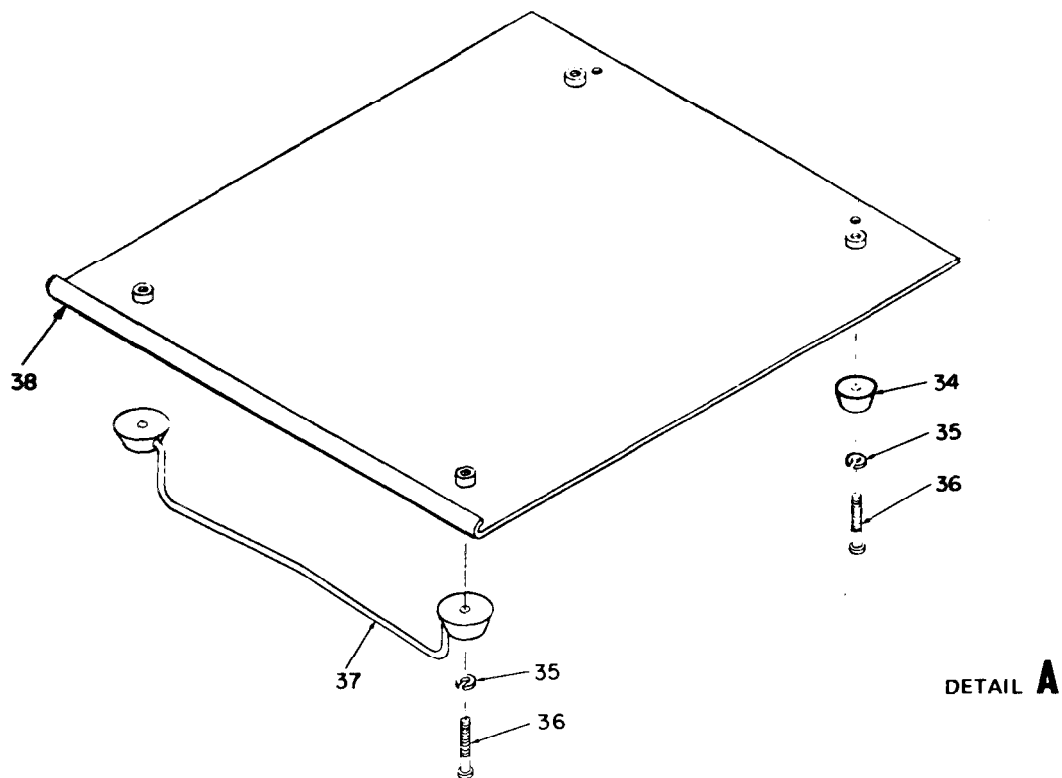

EL6UZ061

Figure 6-13. Digital Voltmeter AN/GSM-64C, Bottom Cover Explosion

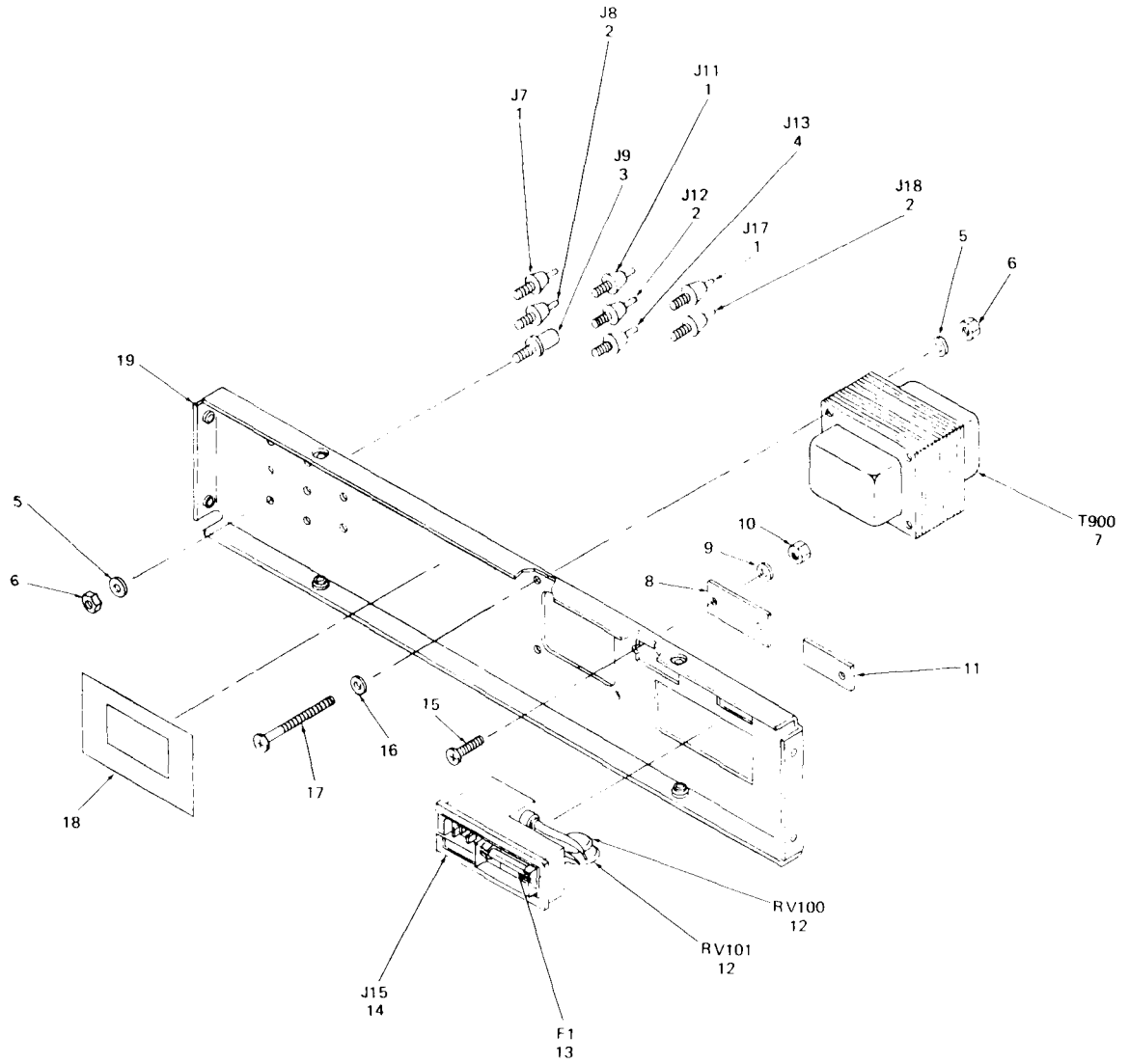

PREFIX ALL REFERENCE DESIGNATIONS WITH A5.

EL6UZ062

Figure 6-14. Digital Voltmeter AN/GSM-64C, Rear Panel Assembly

Section V. PERFORMANCE ASSURANCE TESTS

6-13. General

This section contains performance assurance checks that compare the voltmeter with the applicable performance specifications. These are "in-cabinet" checks that should be made in the sequence outlined and before any attempt is made to calibrate the voltmeter. The performance assurance tests should also be used as part of the troubleshooting procedure and before returning the instrument to regular service after repair, recalibration or extended storage. All checks are to be conducted in a clean, draft-free environment having an ambient temperature of 73°F ± 4°F and a relative humidity less than 70%. Required test equipment is listed in table 6-1.

6-14. Performance Testing

a. Preliminary Set-up. Connect the voltmeter to ac line power and set the controls as follows:

POWER OFF/ON	ON (Pushed in)
SAMPLE RATE	Approx. 1 reading/sec
FUNCTION	VOLTS DC
RANGE	2
AUTO	Out (Manual)

RMT	out
RATIO FULL RANGE	Mid-position
GUARD	NORM (Out)
INPUT	FRONT (Out)
AC NULL	Mid-position
DC ZERO	Mid-position

b. Dc Volts Accuracy Checks

(1) Connect shorting straps between the HI, LO and GUARD INPUT terminals.

(2) Adjust the front panel DC ZERO control for a digital readout of 0.00000 ± .00001. Set the exact DC ZERO by noting the tripping point of the - polarity indicator to + polarity.

(3) Remove the shorting strap from the HI and LO INPUT terminals.

(4) Connect the dc voltage calibrator to the INPUT terminals, observing polarity. See figure 6-15.

(5) Apply each of the voltages shown in table 6-3 to the voltmeter INPUT terminals. The digital display shall indicate as specified.

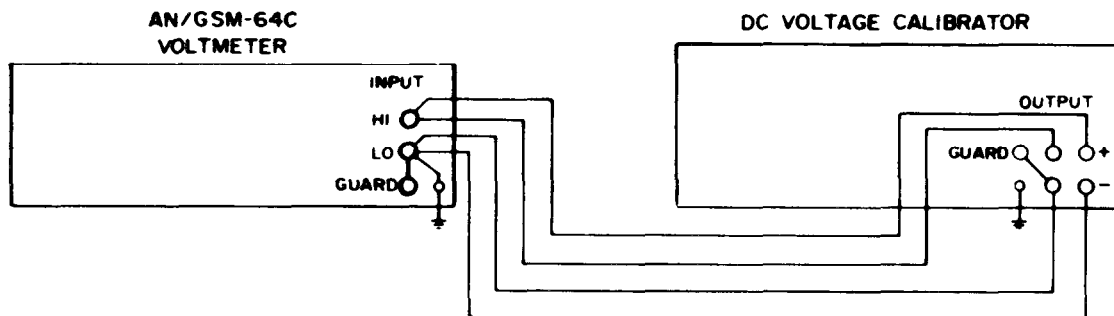

USE FOUR WIRE SENSING CABLES FOR THIS TEST SET UP

EL6UZ025

Figure 6-15. Dc Voltage Accuracy Checks

Table 6-3. Voltmeter Dc Voltage Accuracy Checks

Input volts	Voltmeter Range	Voltmeter Readout Limits	Reading
Short	2*	.00000 ± 1 count	
+1.90000	2	+1.89980 to +1.90020	
+19.000	20	+18.9980 to +19.0020	
-19.000	20	-18.9980 to -19.0020	
+190.00	200	+189.980 to +190.020	
+1000.00	1000	+999.89 to +1000.11	

*Set with DC ZERO control

(6) Repeat step (5) using negative input voltages. The display must indicate the same as for positive inputs, except that the polarity sign will be negative (-).

(7) Press the AUTO pushbutton switch to the "in" position. Disconnect the voltage source and short the INPUT terminal to zero volts. The display shall indicate 0.00000 ± .00001. Reconnect the dc voltage calibrator.

(8) Apply + 1000.00 volts dc to the voltmeter INPUT terminals. The voltmeter shall range automatically and display a digital reading of +1000.00 ± .11.

(9) Disconnect the dc voltage calibrator from the voltmeter.

c. Dc Volts Autoranging Checks

(1) Connect the equipment as shown in figure 6-15 and set the "voltmeter controls as follows:

FUNCTION	VOLTS DC
RANGE	N/A
AUTO	Pushed in
INPUT FRONT/REAR	FRONT (Out)

(2) Apply each of the dc voltages listed in table 6-4 to the voltmeter and observe that the voltmeter automatically transfers to the range indicated.

(3) Repeat step (2) with negative input voltage. The readout must be the same as for positive inputs, except the polarity indication will be negative (-).

Table 6-4. Voltmeter Dc Volts Autoranging Checks

Dc Voltage Calibrator Output	Voltmeter Range	Voltmeter Readout Limits	Reading
+ 1.000 Vdc	2 V	+0.99989 to 1.00011	
+ 10.000 Vdc	20 V	+9.9989 to 10.0011	
+ 100.00 Vdc	200 V	+99.989 to 100.011	
+ 1000.00 Vdc	1000 V	+999.89 to 1000.11	
+ 100.00 Vdc	200 V	+99.989 to 100.011	
+ 10.000 Vdc	20 V	+9.9989 to 10.0011	
+ 1.000 Vdc	2 V	+0.99989 to 1.00011	

d. Dc/dc Ratio Accuracy Checks

(1) Connect the equipment as shown in figure 6-16 and set the controls as follows:

FUNCTION RATIO DC/DC
 RANGE 20
 AUTO Out (Manual)
 INPUT REAR (In)

(2) Set the dc voltage calibrator output to +10.000 volts dc.

(3) Adjust the RATIO FULL RANGE control for a digital display of + 100.000% ± 3 counts.

(4) Reverse the polarity to the INPUT and RATIO terminals.

(5) Repeat step 3 and observe that the voltmeter digital display is +100.000% ± 6 counts.

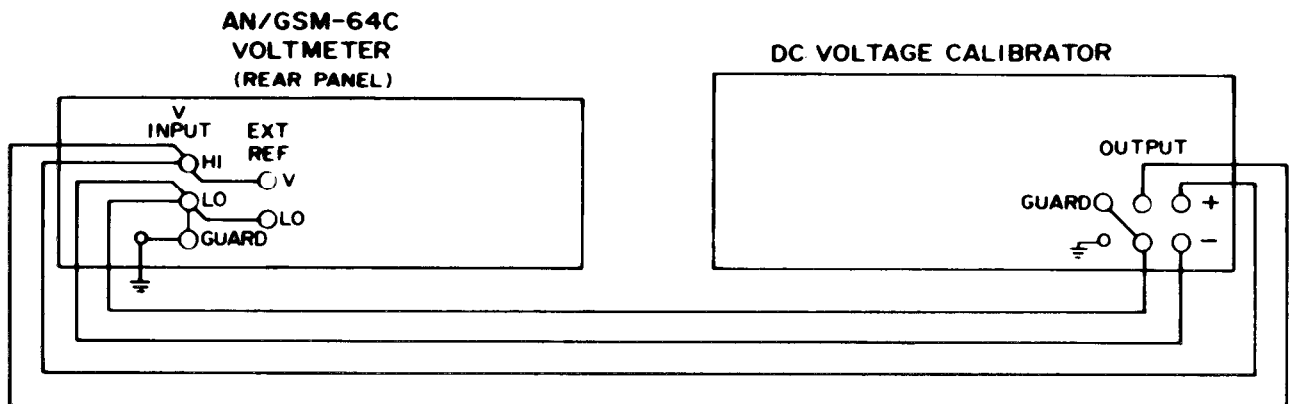

USE FOUR WIRE SENSING CABLES FOR THIS TEST SET UP.
 CONNECT EXT REF TO V INPUT TERMINAL ON VOLTMETER REAR PANEL.

EL6UZ026

Figure 6-16. Dc/dc Ratio Accuracy Checks

(6) Change the dc voltage calibrator output to 3.0000 volts dc.

(7) Repeat step 3 and note that the voltmeter digital display is +100.000% ± 6 counts.

(8) Press the AUTO pushbutton switch to the "in" position and observe that the voltmeter digital display is +100.000% ± 6 counts. Repeat step 3 if necessary.

(9) Disconnect the dc voltage calibrator from the voltmeter.

e. Dc/dc Ratio Autoranging Checks

(1) Connect the equipment as shown in figure 6-16 and set the voltmeter controls as follows:

FUNCTION	DC/DC RATIO
RANGE	N/A
AUTO	Pushed in
INPUT FRONT/REAR	Rear (In)

(2) Apply a + 10.000 Vdc signal to the rear panel EXTERNAL REFERENCE V and LO terminals from the dc voltage calibrator.

(3) Apply each of the dc voltages listed in table 6-5 to the voltmeter rear panel HI and LO INPUT terminals and observe that the voltmeter automatically transfers to the range indicated.

(4) Repeat step (3) with negative input voltages applied to the voltmeter rear panel HI and LO INPUT terminals. The readout must be the same as for positive inputs, except the polarity indication will be negative (-).

Table 6-5. Voltmeter Dc/dc Ratio Autoranging Checks

Dc Voltage Calibrator Output	Voltmeter Range	Voltmeter Display Reading
+10.000 Vdc	20 V	100.000
+18.000 Vdc	20 V	180.000
+100.00 Vdc	200 V	1000.00
+180.00 Vdc	200 V	1800.00
+1000.0 Vdc	1000 V	10000.0
+1800.0 Vdc	1000 V	18000.0
+100.00 Vdc	200 V	1000.00
+18.000 Vdc	200 V	180.000
+10.000 Vdc	20 V	100.000

f. Ac Volts Accuracy Checks

(1) Connect the equipment as shown in figure 6-17 and set the controls as follows:

FUNCTION	VOLTS AC
RANGE	2
AUTO	Out (Manual)

INPUT	FRONT (Out)
SLOW RESPONSE	Out
FILTER LP/10 kHz	In

(2) Connect shorting straps between the HI, LO and GUARD INPUT terminals.

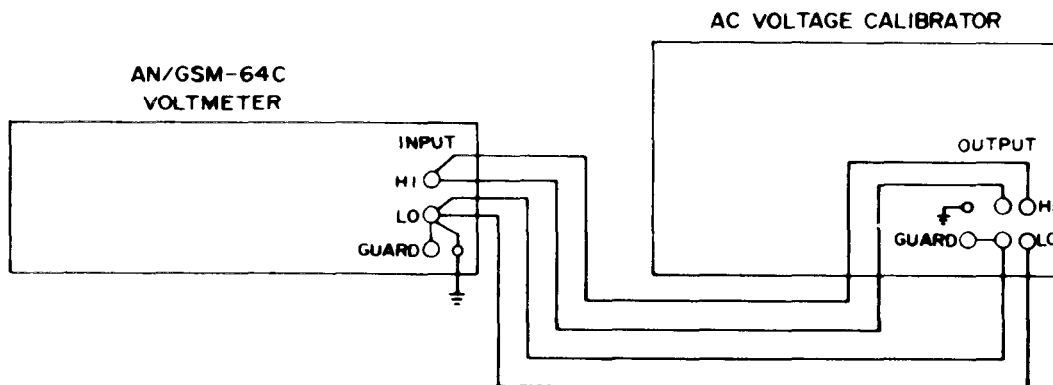

USE FOUR WIRE SENSING CABLE FOR THIS TEST SET UP.

EL0UZ027

Figure 6-17. Ac Voltage Accuracy Checks

(3) Adjust the front panel AC NULL control for a digital readout of 0.00000 (± 100 counts).

(4) Remove the shorting strap from the HI and LO INPUT terminals.

(5) Set the frequency of the ac voltage calibrator to 1000 Hz.

(6) Apply each of the voltages shown in table 6-6 to the voltmeter INPUT terminals. The digital display shall indicate as specified. In order to insure correct range selection of voltmeter in the auto range, reduce calibrator output to lowest level and then return to the desired range.

(7) Disconnect the ac voltage calibrator from the voltmeter.

Table 6-6. Voltmeter Ac Voltage Accuracy Checks

Input		Range	Input Coupling	Response	Limits	Reading
Volts	Frequency					
3	40 Hz	Auto	AC + DC	Normal	2.9340 to 3.0660	
3	100kHz	20V	AC	Normal	2.9360 to 3.0640	
3	1MHz	20V	AC	Normal	2.5100 to 3.4900	
10	40 Hz	20V	AC + DC	Normal	9.9200 to 10.0800	
10	100kHz	Auto	AC	Normal	9.8800 to 10.1200	
10	1MHz	20V	AC	Normal	9.3000 to 10.7000	
19	40 Hz	20V	AC + DC	Normal	18.9020 to 19.0980	
19	100kHz	20V	AC	Normal	18.8080 to 19.1920	
30	40 Hz	200V	AC + DC	Normal	29.640 to 30.360	
30	100kHz	Auto	AC	Normal	29.360 to 30.640	
100	40 Hz	Auto	AC + DC	Normal	99.200 to 100.800	
100	100kHz	200V	AC	Normal	98.800 to 101.200	
190	40 Hz	200V	AC + DC	Normal	189.020 to 190.980	
190	100kHz	200V	AC	Normal	188.080 to 191.920	
300	40 Hz	Auto	AC + DC	Normal	296.40 to 303.60	
300	100kHz	1000V	AC	Normal	293.60 to 306.40	
1000	40 Hz	1000V	AC + DC	Normal	992.00 to 1008.00	
1000	100kHz	Auto	AC	Normal	988.00 to 1012.00	

Section VI. FINAL ADJUSTMENTS

6-15. General

This section contains adjustment procedures for the Digital Voltmeter AN/GSM-64C. Do not attempt to make any of these adjustments before performing the performance assurance checks located in the previous section. Items of equipment in this procedure are referenced within the text by common name and item identification number as listed in tables 6-7 and 6-8. For the identification of equipment referenced by item numbers prefixed with A, see table 6-7. For those items of equipment referenced by item

numbers prefixed B, see table 6-8. Be aware of the serial number of the instrument under test, since some adjustment procedures are specifically for instruments with serial numbers referenced in this procedure.

NOTE

Perform the calibration procedure in the sequence given, as some of the adjustments are interrelated.

Table 6-7. Minimum Specifications of Equipment Required

Item	Common Name	Minimum Use Specifications	Manufacturer Model and Part Number
A1	Dc voltage calibrator ¹	Output voltage: 1.0 to 1000 Vdc Output accuracy: $\pm 0.0025\%$	Fluke Model 332B (7911393)
A2	Ac voltage calibrator	Output voltage: 1 mV to 1000 Vac Output accuracy: 30 Hz - 30 kHz 1 mV - 100 V: $\pm 0.05\%$ 100 V - 1000 V: $\pm 0.1\%$ 30 kHz - 100 kHz 1 mV - 1000 V: $\pm 0.2\%$ 100 kHz - 1 MHz 1 mV - 100 V: $\pm 0.4\%$	Fluke Model 5200A and Model 5215A
A3	Dc differential volt-meter	Dc differential accuracy: $\pm (0.005\% \text{ of input} + 5 \text{ uV})$ Resolution: 1 ppm on 1 V range	Fluke Model 887AB (MIS-10216)
A4	Autotransformer	Range: 103 to 127 Vac Accuracy: $\pm 1\%$	General Radio Model W10MT3AS3 (7910819)
A5	Digital multimeter	Range full scale: 20 Vdc Dc accuracy: $\pm (0.2\% \text{ of reading} + 1 \text{ digit})$	Ballantine Model 9632M (6625-01-060-6804) AN/USM-451

Table 6-7. Minimum Specifications of Equipment Required - Cont'd

Item	Common Name	Minimum Use Specifications	Manufacturer Model and Part Number
A6	Oscilloscope	Bandwidth: Dc - 10 MHz Vertical Sensitivity: 5 mV	Ballantine Model 1031A
A7	Function generator	Output (Open Circuited): 20 V p-p Function: Sinewave Frequency Range: 0.1 Hz to 1 MHz	Hewlett Packard Model 3311A
A8	True rms ac/dc transfer standard	Frequency Range: Dc, 5 Hz to 30 MHz Voltage Range: 0.5 to 1 V Accuracy of Ac to Dc Transfer: $\pm 0.01\%$	Ballantine Model 1600A
A9	Pulse generator	9 to 1 duty cycle and 4 V from 0 base	Hewlett Packard 214A
A10	Dial-a-volt	0 to 10 V, 1 percent accuracy	General Resistance Model DAV46D

¹two required

Table 6-8. Accessories Required

Item	Common Name	Description and Part Number
B1	GR874 series Tee adapter	Ballantine Type 10186A
B2	BNC female to dual banana adapter ¹	Ballantine Type 12617A
B3	GR874 series to BNC female ¹	Ballantine Type 12620A
B4	Cable assembly BNC male to BNC male ²	Ballantine Type 12249D
B5	50 Ω termination BNC male to BNC female	Ballantine Type 12630A
B6	Probe, X10, 5 Feet	Ballantine Type 10601C
B7	Shorting jumper	Ballantine Type 85-10125-0A
B8	Lead ²	24-in (red) single banana plug terminations 85-10123-0A
B9	Lead ²	24-in (black) single banana plug terminations 85-10124-0A

¹two required

²three required

6-16. Dc Volts Accuracy Adjustments

a. 1 V Down Range Adjustment (A9-R18)

(1) Adjust the SAMPLE RATE control for approximately one display readout every second.

(2) Select the 20V range on the voltmeter.

(3) Release the AUTO switch to the "out" position.

(4) Select the DC/DC RATIO mode.

(5) Connect the equipment as shown in figure 6-18.

(6) Apply a -10.00 Vdc signal from the dc voltage calibrator (A1) simultaneously to the voltmeter HI/LO INPUT (front) terminals and V/LO EXTERNAL REFERENCE terminals.

(7) Adjust the front panel RATIO FULL RANGE control for a display reading of +100.000.

(8) Reduce the signal from the dc voltage calibrator to -1.000 Vdc.

(9) Adjust A9-R18 for a display reading of +100.000 (± 6 counts). Refer to figure 6-19 for the location of adjustments.

NOTE

If it is not possible to adjust A9-R18 to within ± 6 counts due to excessive random noise peaks, proceed with the following steps.

(10) Rotate the SAMPLE RATE control fully counterclockwise to the detented HOLD position.

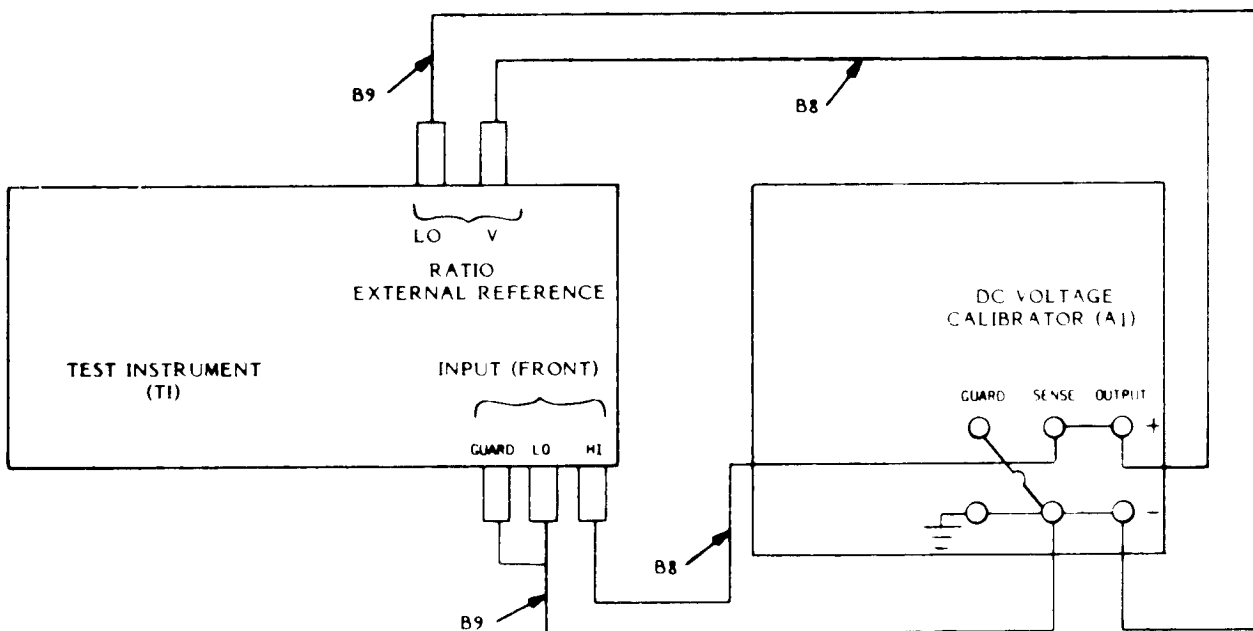

EL6UZ043

Figure 6-18. Dc Volts Calibration, Equipment Connections

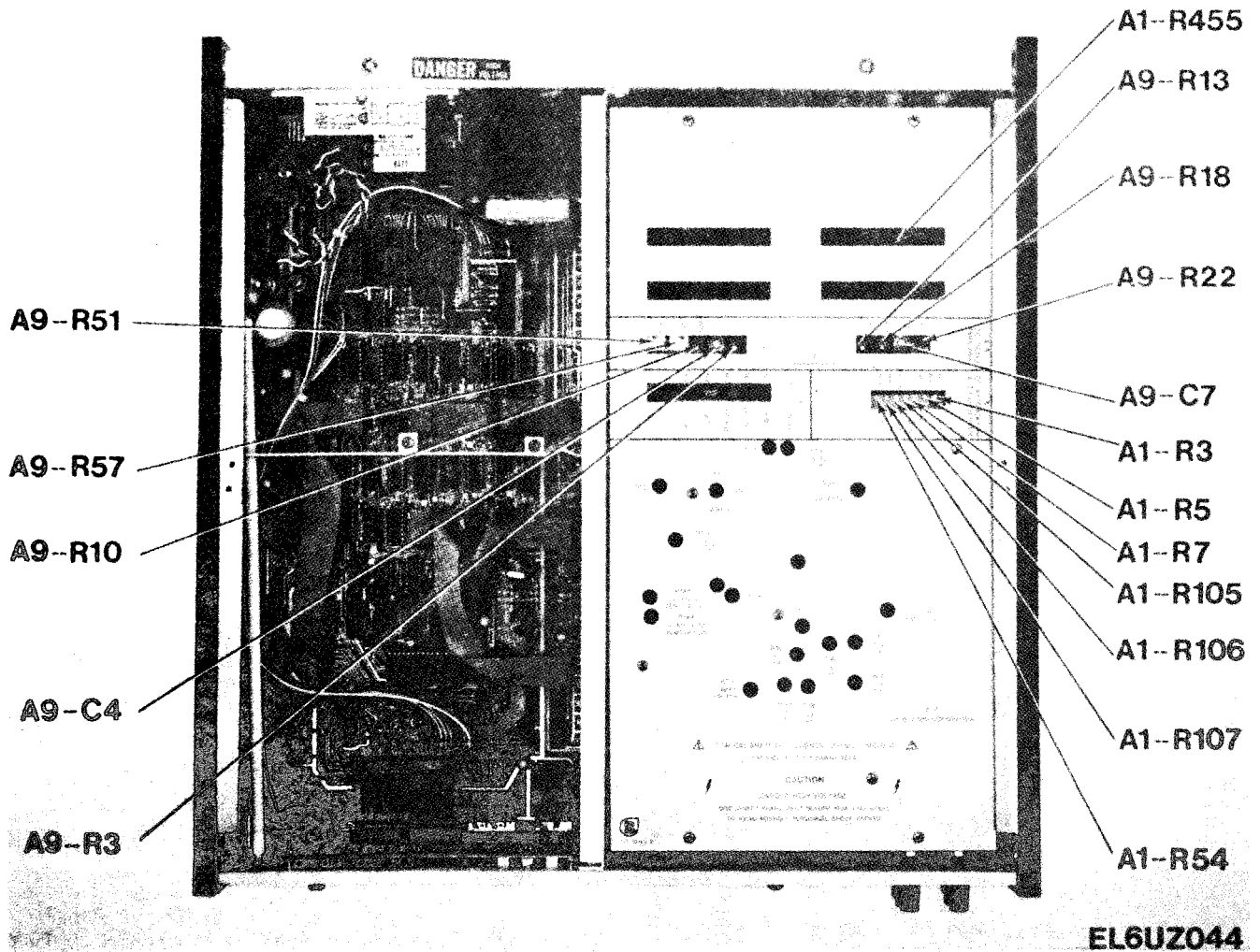

Figure 6-19. Location of Adjustments, Analog and Ratio Boards

(11) Manually initiate a sample reading by pressing the RESET switch. Record the displayed reading. Repeat this procedure nine more times for a total of ten manual samplings.

(12) Calculate the difference between the recorded sample reading displayed and 100.000 for each of the ten readings. Ignore the negative sign for all samples less than 100.000 and total the ten numbers.

(13) Divide the total by ten, The resulting number must not exceed 12.

NOTE

For the following adjustment procedure, make sure that the RATIO FULL RANGE control is not moved from its previous position.

b. Bias Adjustment (A1-R54)

(1) Adjust the SAMPLE RATE control for approximately one display readout every second.

(2) Apply +10.00 Vdc to the voltmeter from the dc voltage calibrator. Observe the display readout.

(3) Reduce the signal from the dc voltage calibrator to +1.000 Vdc.

(4) Adjust A1-R54 for a display reading of +100.000 (± 6 counts).

NOTE

If it is not possible to adjust A1-R54 to within ± 6 counts due to excessive random noise peaks, follow the same procedure as outlined in step (10) of the previous procedure.

c. Zero Width Adjustment (A1-R107)

(1) Adjust the SAMPLE RATE control for approximately one display readout every second.

(2) Select the 20 V range on the voltmeter.

(3) Release the AUTO switch to the "out" position.

(4) Apply +10.00 mV dc to the voltmeter INPUT terminals from the dc voltage calibrator (A1). Observe the display readout.

(5) Reverse the connections to the voltmeter INPUT terminal and observe the display readout. The absolute value should be the same as that obtained in step (4).

(6) If the two readings do not agree, adjust the DC ZERO control to produce a display readout that is halfway between the positive and negative readings obtained in steps (4) and (5).

(7) Repeat steps (4) through (6) until both absolute readings are the same.

(8) Connect the dc voltage calibrator leads directly to produce a positive readout.

(9) Adjust A1-R107 for a readout of

+0.0100 (Refer to figure 6-19 for the location of adjustments.)

(10) Reverse the connections to the voltmeter. The displayed readout should now be -0.0100 ± 0.0001 .

(11) Repeat steps (4) through (10) until these requirements are satisfied.

d. -1.9 V FULL Range Adjust (A1-R106)

(1) Select the 2 V range on the voltmeter.

(2) Apply -1.90000 Vdc to the voltmeter INPUT terminals from the dc voltage calibrator. Observe the display readout.

(3) Adjust A1-R106 for a display readout of -1.90000 volts.

e. -19 V Full Range Adjust (A 1-R3)

(1) Select the 20 V range on the voltmeter.

(2) Apply -19.0000 Vdc to the voltmeter INPUT terminals from the dc voltage calibrator. Observe the display readout.

(3) Adjust A1-R3 for a display readout of -19.0000 volts.

f. Turnover Adjust (A1-R105)

(1) Continuing with the same setup described in the previous step, reverse the connections to the voltmeter INPUT terminals. This results in a +19.000 Vdc signal being applied to the voltmeter.

(2) observe the display and adjust A1-R105 for a display readout of +19.0000 volts.

(3) Connect the dc voltage calibrator leads directly (not reversed) to the voltmeter.

g. +190 V Full Range Adjust (A1-R5)

(1) Select the 200 V range on the voltmeter.

(2) Apply +190.00 Vdc to the voltmeter INPUT terminals from the dc voltage calibrator. Observe the display readout.

(3) Adjust A1-R5 for a display readout of +190.000 Volts.

h. +1 kV Full Range Adjust (A1-R7)

(1) Select the 1000 V range on the voltmeter.

(2) Apply +1000.0 Vdc to the voltmeter INPUT terminals from the dc voltage calibrator. Observe the display readout.

(3) Adjust A1-R7 for a display readout of +1000.00 volts.

WARNING

Reduce the dc voltage calibrator output signal level to below 1 volt before removing the leads from the voltmeter.

6-17. Dc Ratio Accuracy Adjustments

a. 10 V Full Range (A9-R3)/10 V Dc Common Mode (A9-R13)

(1) Set the RATIO FULL RANGE control (10 turn) to its mechanical center of rotation and leave it at this setting.

(2) Select the 20 V range and DC/DC RATIO function on the voltmeter.

(3) Connect a dc voltage calibrator (A1) to the voltmeter HI/LO INPUT (front) terminals. See figure 6-20.

(4) Connect a second dc voltage calibrator (A1) to the voltmeter V/LO EXTERNAL REFERENCE terminals.

(5) Apply -10.00 Vdc signals from both dc voltage calibrators to the voltmeter.

(6) Connect the minus (-) terminal of the

dial-a-volt (A10) to the voltmeter LO INPUT (front) terminal and connect the positive (+) terminal to the voltmeter LO EXTERNAL REFERENCE terminal. (Refer to figure 6-20.)

(7) Set the dial-a-volt to +1 mV.

(8) Adjust the SAMPLE RATE control for approximately one display readout every second.

(9) Adjust A9-R3 to achieve a reading half-way between the initial readout observed and +100.000 (Refer to figure 6-19 for the location of adjustments.)

(10) Adjust A9-R13 for a display readout of +100.000.

(11) increase the dial-a-volt output to +10 V and observe the display readout.

(12) if readout increases (i.e. +100.100), adjust A9-R13 for a readout negative by the same amount (i.e. +99.900).

(13) Adjust A9-R3 to bring the display readout back to +100.000.

(14) if readout decreases (i.e. +99.900), adjust A9-R13 for a readout positive by the same amount (i.e. +100.100).

(15) Adjust A9-R3 to restore the display readout to +100.000.

(16) Reduce the dial-a-volt output to +1 mV. The display should still indicate +100.000 (± 000.010). If it does not, repeat steps (9) through (14).

(17) Disconnect all equipment connections from the voltmeter.

b. 60 Hz Common Mode Adjustments (A9-C4, C7)

(1) Connect a shorting jumper (B7) between the V and LO EXTERNAL REFERENCE terminals on the voltmeter.

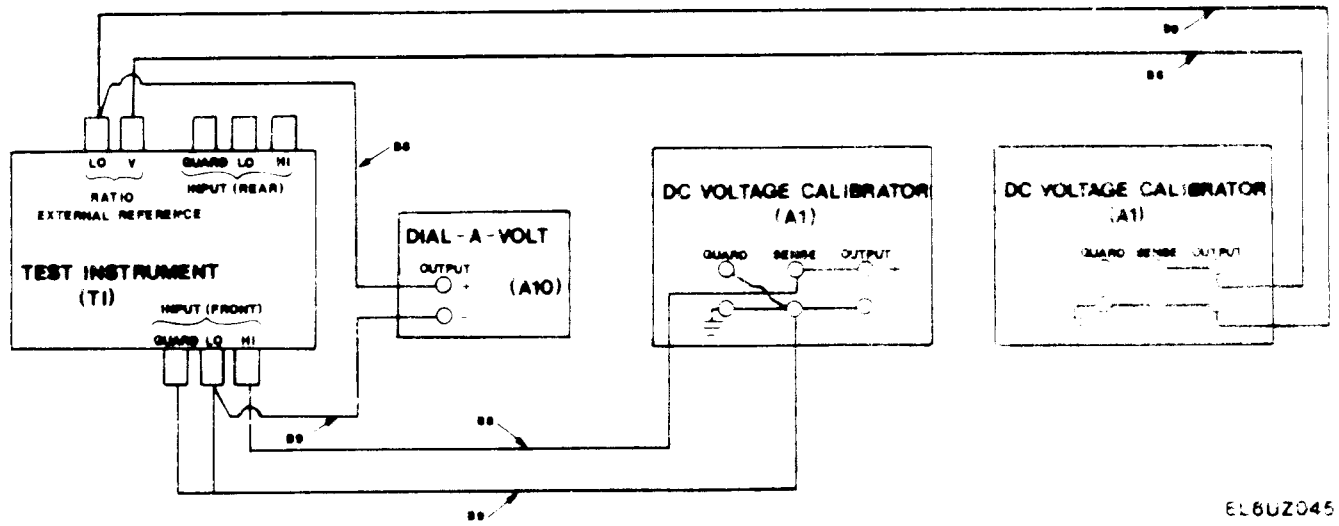

EL6UZ045

Figure 6-20. DC Ratio Calibration, Equipment Connections

(2) Connect the function generator (A7) as shown in figure 6-21.

(3) Select the sinewave output from the function generator and adjust it for a frequency of 60 Hz and a level of 20 V P-P as measured by the oscilloscope (A6).

(4) Remove the top cover of the guard cage and connect the oscilloscope to A9-U1, pin 6 on the voltmeter. (Refer to figure 6-22 for test point locations.)

(5) Set the oscilloscope time base to 20 ms/div, vertical sensitivity to 5 mV/div and select ac coupling. Set the probe switch to the XI position.

(6) Adjust trimmers A9-C4 and A9-C7 to reduce the amplitude to less than 20 mV P-P as displayed on the oscilloscope.

(7) Disconnect all equipment connections from the voltmeter.

c. 100 V Full Range (A9-R10)/100 Vdc Common Mode (A9-R22)

(1) Check that the RATIO FULL RANGE control is still set at its mechanical center of rotation.

(2) Select the 200 V range and DC/DC RATIO function on the voltmeter.

(3) With the equipment connected as shown in figure 6-20, apply a +100.00 Vdc signal from the dc voltage calibrator simultaneously to the voltmeter HI/LO INPUT (front) terminals and V/LO EXTERNAL REFERENCE terminals.

(4) Set the dial-a-volt to +1 mV.

(5) Adjust SAMPLE RATE control for approximately one display readout every second;

(6) Adjust A9-R10 to achieve a reading half-way between the initial readout observed and +100.000.

(7) Adjust A9-R22 for a display readout of +100.000.

(8) Increase the dial-a-volt output to +10V and observe the display readout.

(9) If readout increases (i.e. +100.100), adjust A9-R22 for a readout negative by the same amount (i.e. +99.900).

(10) Adjust A9-R10 to bring the display readout back to +100.000.

(11) If readout decreases (i.e. +99.900), adjust A9-R22 for a readout positive by the same amount (i.e. +100.100).

(12) Adjust A9-R10 to restore the display readout to +100.000.

(13) Reduce the dial-a-volt output to +1. The display should still indicate +100.000 (+000.010). If it does not, repeat steps (8) through (13).

(14) Disconnect the dial-a-volt.

d. 1 V Down Range Adjustment (A9-R18)

(1) Connect the equipment as shown in figure 6-18.

(2) Select the 20 V range and DC/DC RATIO function on the voltmeter.

(3) Apply a +10.00 Vdc signal from the dc voltage calibrator simultaneously to the voltmeter HI/LO INPUT (front) terminals and V/LO EXTERNAL REFERENCE terminals.

(4) Adjust the front panel RATIO FULL RANGE control for a reading of +100.000.

(5) Reduce the signal from the dc voltage calibrator to +1.00 Vdc. If the display reading changes, adjust A9-R18 to restore it to an average reading of + 100.000.

(6) Repeat steps (3) through (5) until there is no change between the display reading for

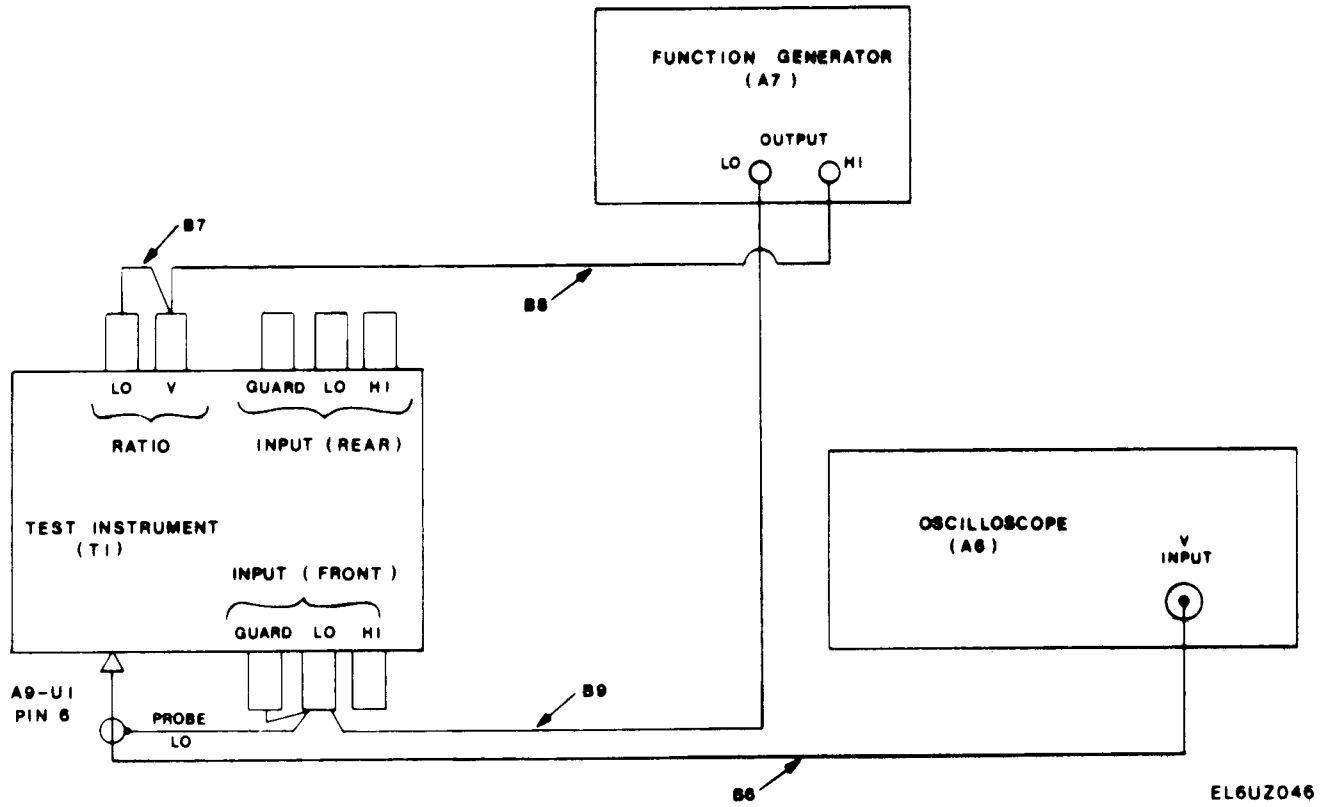

Figure 6-21. DC Ratio Calibration, Equipment Connections

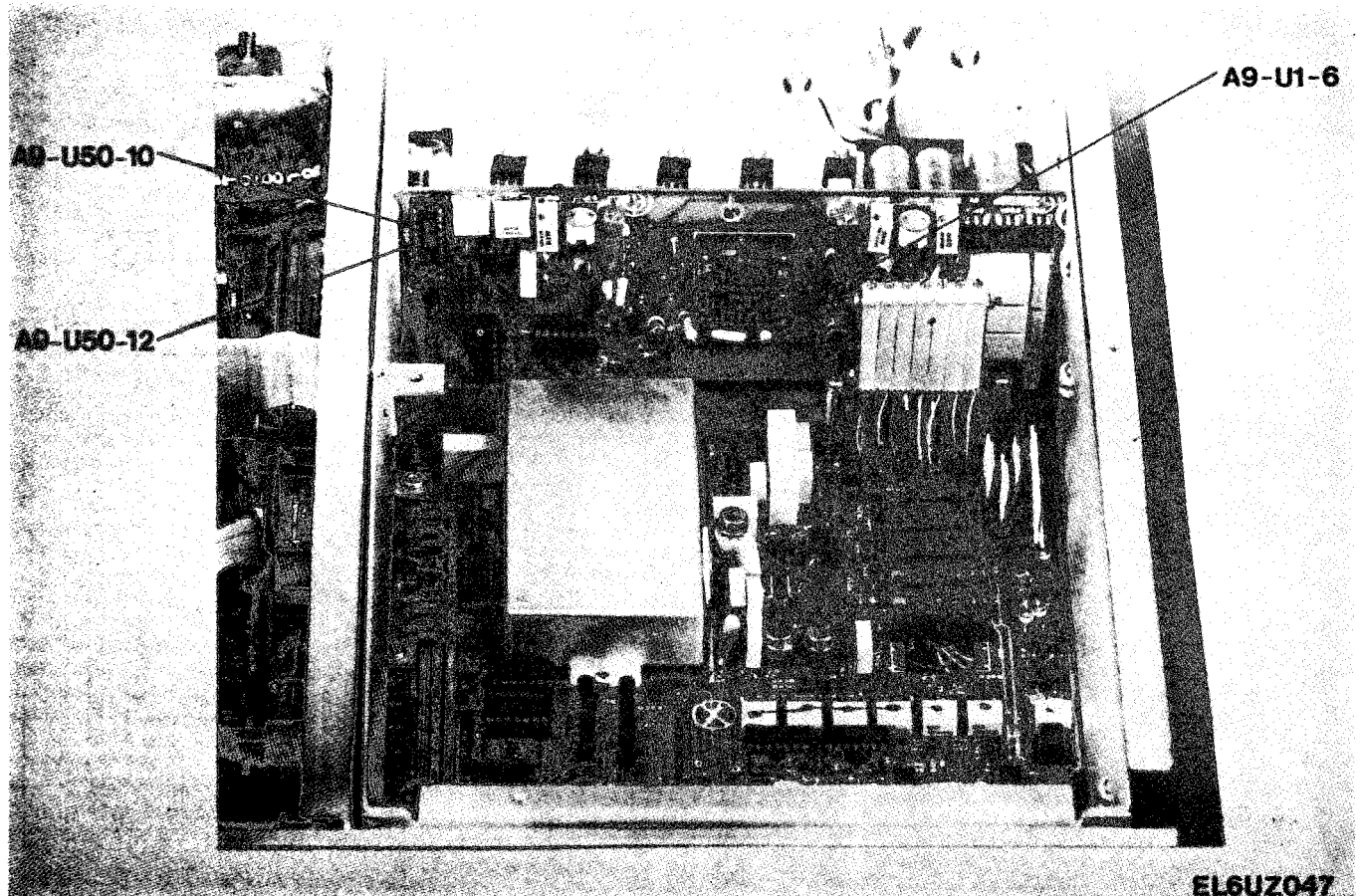

Figure 6-22. Location of Test Points

+10.00 Vdc input signal and that for +1.00 Vdc input signal.

e. -1V FR Ratio Adjustment (A1-R455)

(1) Select the 20 V range and DC/DC RATIO function on the voltmeter.

(2) Apply a -10.0 Vdc signal from the dc voltage calibrator to both the voltmeter HI/LO INPUT (front) terminals and the V/LO EXTERNAL REFERENCE terminals, simultaneously.

(3) Adjust the front panel RATIO FULL RANGE control for a display of +100.000.

(4) Switch the voltmeter to the 2 V range

and apply a -1.0 volt signal from the dc voltage calibrator.

(5) Adjust A1-R455 for an indication of +100.000.

NOTE

A1-R455 is accessible through the right rear rectangular cut-out of the top shield.

f. Auto Down Range Detector Adjustment (A9-R57)

(1) Connect the equipment as shown in figure 6-23.

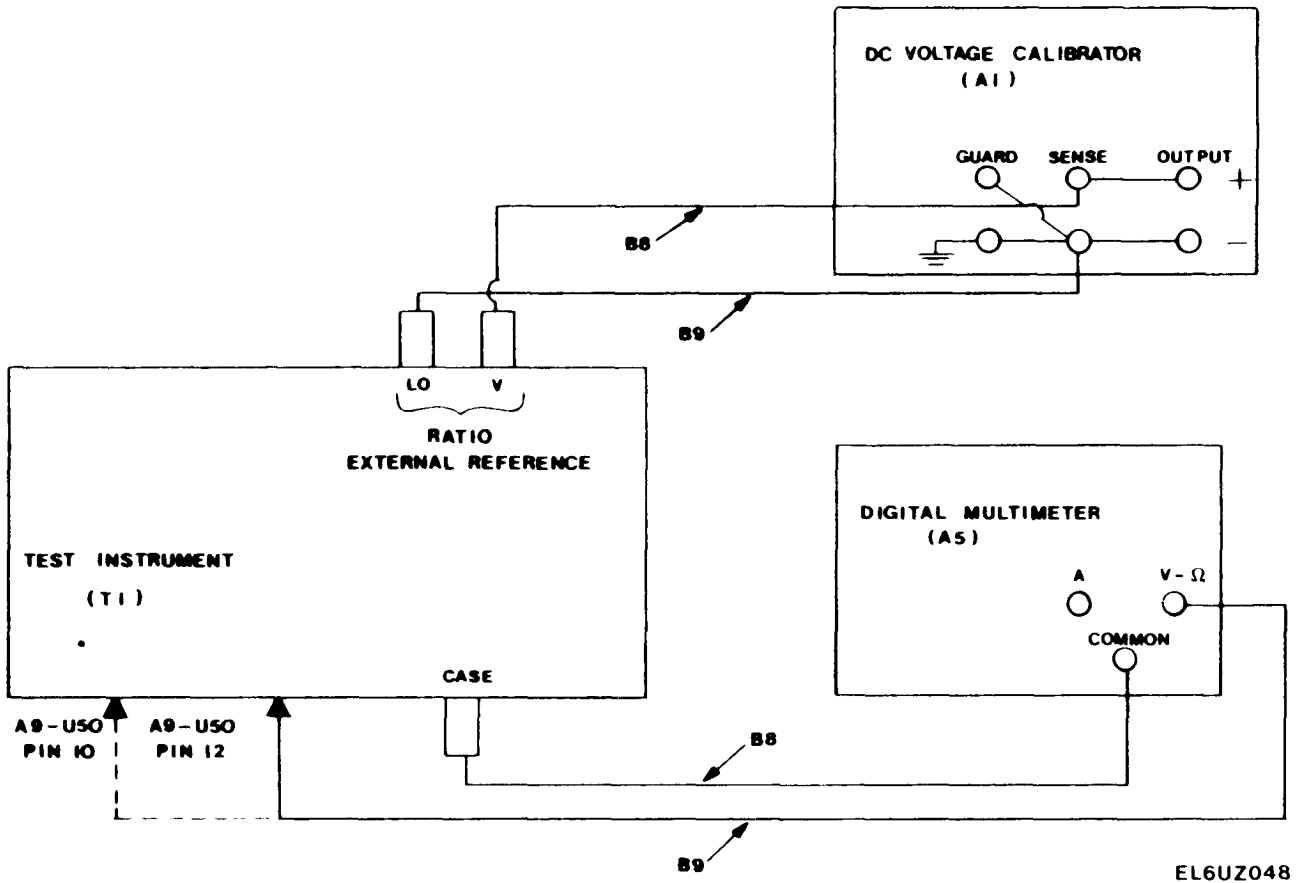

Figure 6-23. DC Ratio Auto Range Detector Calibration

- (2) Select the 20 V range and DC/DC RATIO function on the voltmeter.
- (3) Apply a +1.05 Vdc signal from the dc voltage calibrator to the V/LO EXTERNAL REFERENCE terminals.
- (4) Set the digital multi meter (A5) to the 20 Vdc range. Remove the top cover of the guard cage and connect the V-Ω test lead to A9-U50, pin 12 on the voltmeter. (See figure 6-22.)
- (5) Adjust A9-R57 until the voltage at A9-U50, pin 12 just switches from +5 V to -15 V (or from -15 V to +5 V).

- (6) Increase the input signal from the dc voltage calibrator to +1.07 Vdc. The voltage at A9-U50, pin 12 should read +5 volts.
- (7) Decrease the input signal from the dc voltage calibrator to +1.03 Vdc. The voltage at A9-U50, pin 12 should read -15 volts.

g. Auto Up Range Detector Adjustment (A9-R51)

- (1) Connect the equipment as shown in figure 6-23. Change the digital multi meter V/Ω test lead to monitor the voltage at A9-U50, pin 10.

(2) Select the 200 V range and DC/DC RATIO function on the voltmeter.

(3) Apply a +112.0 Vdc signal from the dc voltage calibrator to the V/LO EXTERNAL REFERENCE terminals.

(4) Adjust A9-R51 until the voltage at A9-U50, pin 10 just switches from +5 V to -15V (or from -15 V to +5 V).

(5) Decrease the input signal from the dc voltage calibrator to +111.0 Vdc. The voltage at A9-U50, pin 10 should read +5 volts.

(6) Increase the input signal from the dc voltage calibrator to +113.0 volts. The voltage at A9-U50, pin 10 should read -15 volts.

(7) Replace the top cover of the guard cage.

6-18. Dc Volts Autoranging Adjustments

a. > + 195000 Up Range Trip Point Adjustment (A1-R406). Refer to figure 6-24 for location of adjustments.

(1) Remove the top Guard Cage Cover.

(2) Remove the True Rms Converter Board Assembly (A7).

(3) Connect the equipment as shown in figure 6-25.

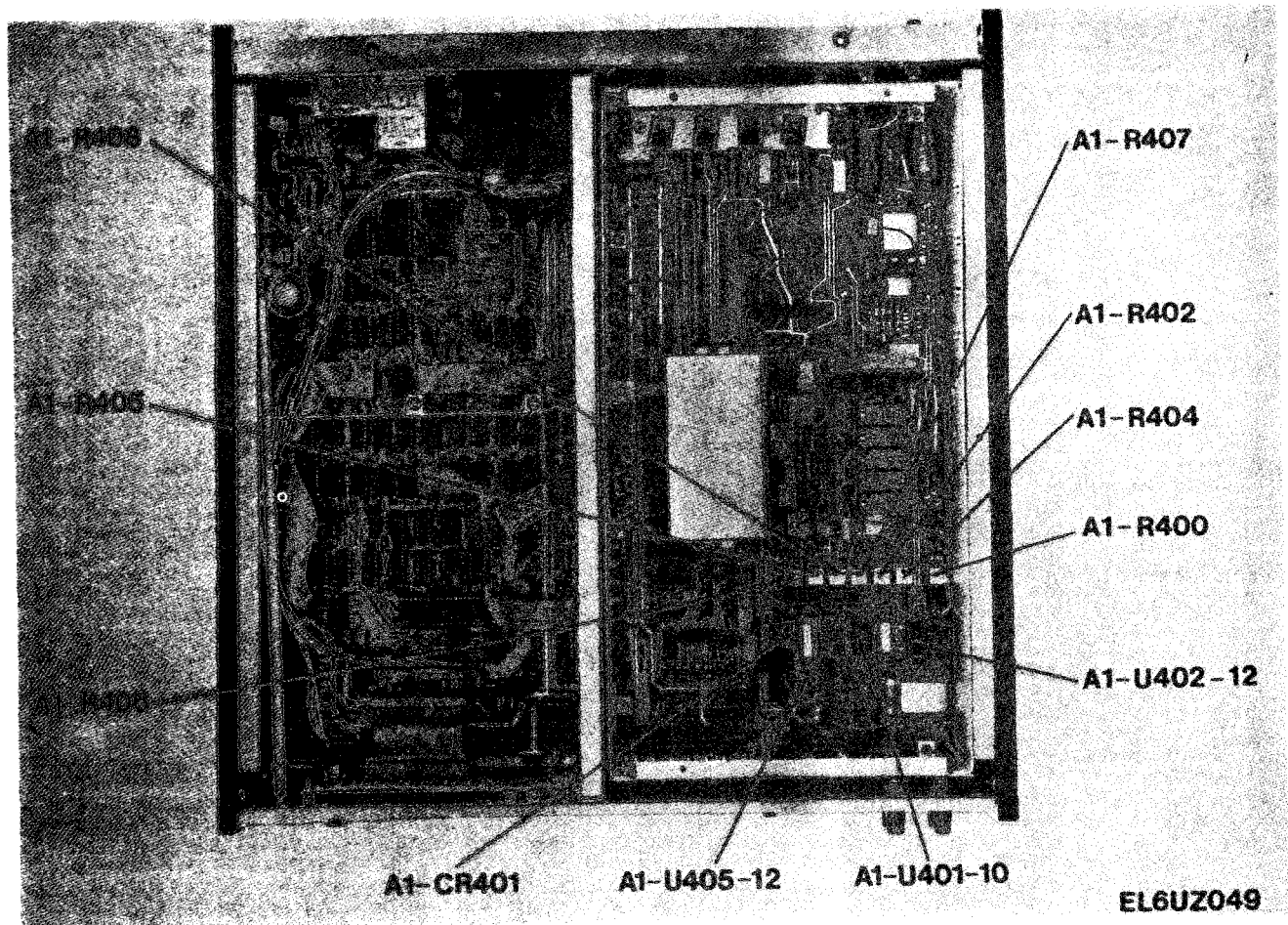

Figure 6-24. Location of Adjustments and Test Points, Autoranging

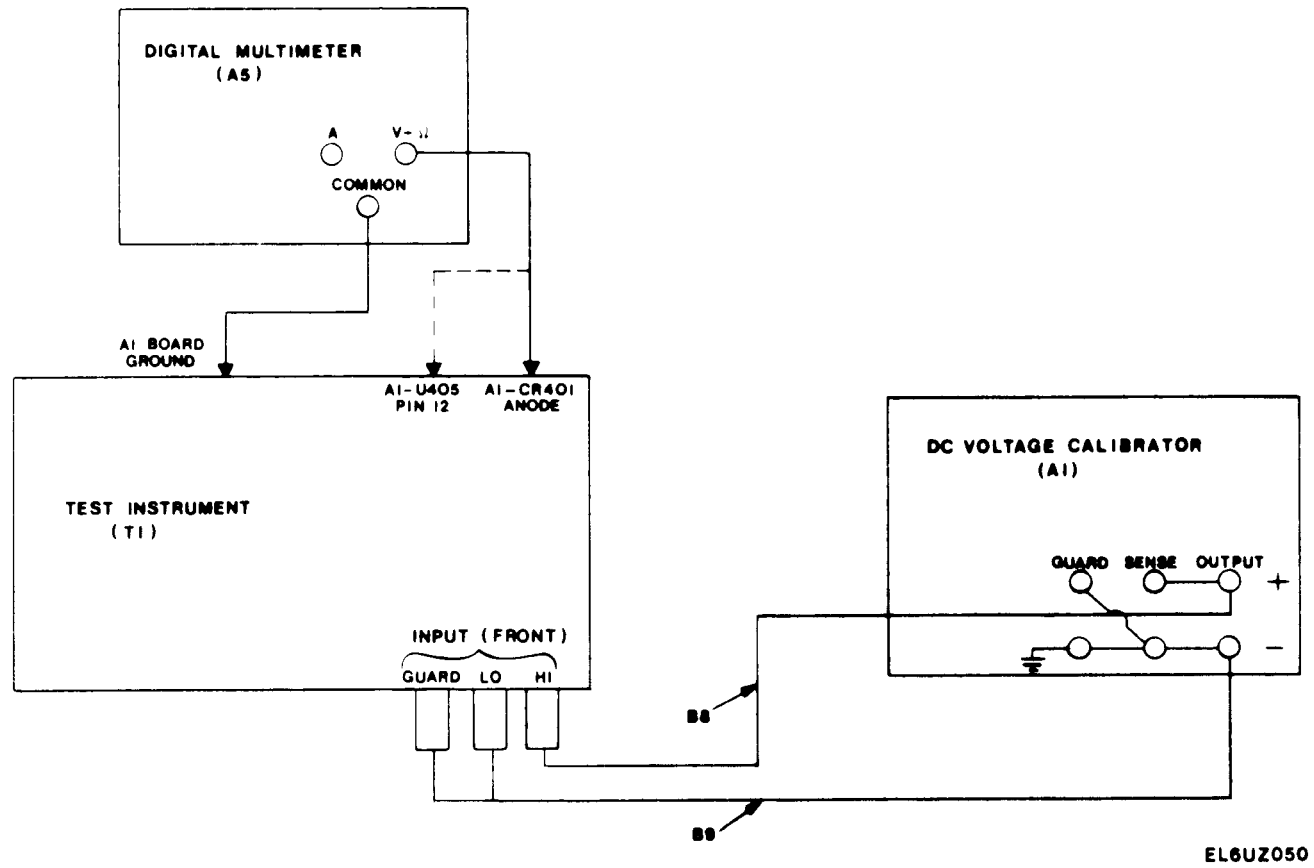

Figure 6-25. DC Voltage Autoranging, Equipment Connections

(4) Set the voltmeter to VOLTS DC and select the 2 V range.

(5) Set the digital multimeter (A5) to the 20 Vdc range.

(6) Apply +1.9500 Vdc to the voltmeter INPUT terminals from the dc voltage calibrator (A1).

(7) Adjust A1-R406 so that the voltage monitored by the digital multimeter just trips from approximately +2.5 Vdc to approximately -14.0 Vdc.

(8) Reduce the dc voltage calibrator output to +1.9400 Vdc. The voltage monitored by the digital multimeter should trip back to +2.5 Vdc.

(9) Increase the dc voltage calibrator output to +1.9600 Vdc. The voltage monitored by the digital multimeter should trip back to -14.0 Vdc.

b. > -195000 Up Range Trip Point Adjustment (A1-R405)

(1) Change the voltage applied to the voltmeter INPUT terminals to -1.9500 Vdc.

(2) Adjust A1-R405 so that the voltage monitored by the digital multimeter just trips from approximately +2.5 Vdc to approximately -14.0 Vdc.

(3) Reduce the dc voltage calibrator output to -1.9400 Vdc. The voltage monitored by the digital multimeter should trip back to +2.5 Vdc.

(4) Increase the dc voltage calibrator output to -1.9600 Vdc. The voltage monitored by the digital multimeter should trip back to -14.0 Vdc.

c. < +12000 Down Range Trip Point Adjustment (A1-R407)

(1) Move the digital multimeter V- Ω test lead from A1-CR401 anode to A1-U405, pin 12.

(2) Apply +0.12000 Vdc to the voltmeter INPUT terminals from the dc voltage calibrator.

(3) Adjust A1-R407 so that the voltage monitored by the digital multimeter just trips from approximately -14.0 Vdc to approximately +5.0 Vdc.

(4) Increase the dc voltage calibrator output to +0.13000 Vdc. The voltage monitored by the digital multimeter should trip back to -14.0 Vdc.

(5) Reduce the dc voltage calibrator output to +0.11000 Vdc. The voltage monitored by the digital multimeter should trip back to +5.0 Vdc.

d. <-12000 Down Range Trip Point Adjustment (A1-R408)

(1) Change the voltage applied to the voltmeter INPUT terminals to -0.12000 Vdc.

(2) Adjust A1-R408 so that the voltage monitored by the digital multimeter just trips from approximately -14.0 Vdc to approximately +5.0 Vdc.

(3) Increase the dc voltage calibrator output to -0.13000 Vdc. The voltage monitored by the digital multimeter should trip back to -14.0 Vdc.

(4) Reduce the dc voltage calibrator output to -0.11000 Vdc. The voltage monitored by the digital multimeter should trip back to +5.0 Vdc.

6-19. Dc/dc Ratio Autoranging Adjustments

a. RATIO FULL RANGE control setting. Refer to figure 6-24 for location of adjustments.

(1) Apply a +1.000 Vdc signal to the EXTERNAL REFERENCE V and LO terminals on the voltmeter rear panel from the first dc voltage calibrator (A1).

(2) Apply a +1.8000 Vdc signal to the voltmeter front panel HI and LO INPUT terminals from the second dc voltage calibrator (A1).

(3) Adjust the voltmeter front panel RATIO FULL RANGE control for a display reading of +180.000 (± 20 counts).

NOTE

For the balance of Dc Ratio Auto-ranging adjustments do not disturb the setting of the RATIO FULL RANGE control.

b. Ratio > +180000 Up Range Trip Point

(1) Connect the equipment as shown in figure 6-26.

(2) Apply a +1.000 Vdc signal to the EXTERNAL REFERENCE V and LO terminals on the voltmeter rear panel from the first dc voltage calibrator (A1).

(3) Reduce the voltage applied to the voltmeter front panel INPUT terminals to +1.7000 Vdc.

(4) Observe that the voltage monitored by the digital multimeter is approximately +5.0 Vdc.

(5) Increase the voltage applied to the voltmeter front panel INPUT terminals to +1.9000 Vdc.

(6) Observe that the voltage monitored by the digital multi meter is approximately -15.0 Vdc.

c. Ratio > -180000 Up Range Trip Point Adjustment (A1-R404)

(1) Apply a +1.000 Vdc signal to the EXTERNAL REFERENCE V and LO terminals on the voltmeter rear panel from the first dc voltage calibrator.

(2) Apply a -1.8000 Vdc signal to the voltmeter front panel HI and LO INPUT terminals

from the second dc voltage calibrator.

(3) Adjust A1-R404 until the voltage monitored by the digital multimeter at A1-U402, pin 12 just trips from approximately +5.0 Vdc to -15.0 Vdc.

(4) Check for proper trip point operation by first, reducing the front panel INPUT signal to -1.7000 Vdc and observing that the digital multimeter measures approximately +5.0 Vdc; and second, increasing the front panel INPUT signal to -1.9000 Vdc and observing that the digital multimeter measures approximately -15.0 Vdc.

d. Ratio < +14000 Down Range Trip Point Adjustment (A1-R400)

(1) Continue with the same setup as in the previous step.

(2) Change the digital multimeter (A5) V-test lead to monitor the signal at A1-U401, pin 10.

(3) Apply a +0.1400 Vdc signal to the voltmeter front panel INPUT terminals from the second dc voltage calibrator.

(4) Adjust A1-R400 until the voltage measured by the digital multi meter at A1-U401, pin 10 just trips from approximately -15.0 Vdc to approximately +5.0 Vdc.

(5) Increase the voltage applied to the voltmeter front panel INPUT terminals to +0.1500 Vdc.

(6) Observe that the voltage measured by the digital multimeter is approximately -15.0 Vdc.

(7) Reduce the voltage applied to the voltmeter front panel INPUT terminals to +0.1300 Vdc.

(8) Observe that the voltage measured by the digital multimeter is approximately +5.0 Vdc.

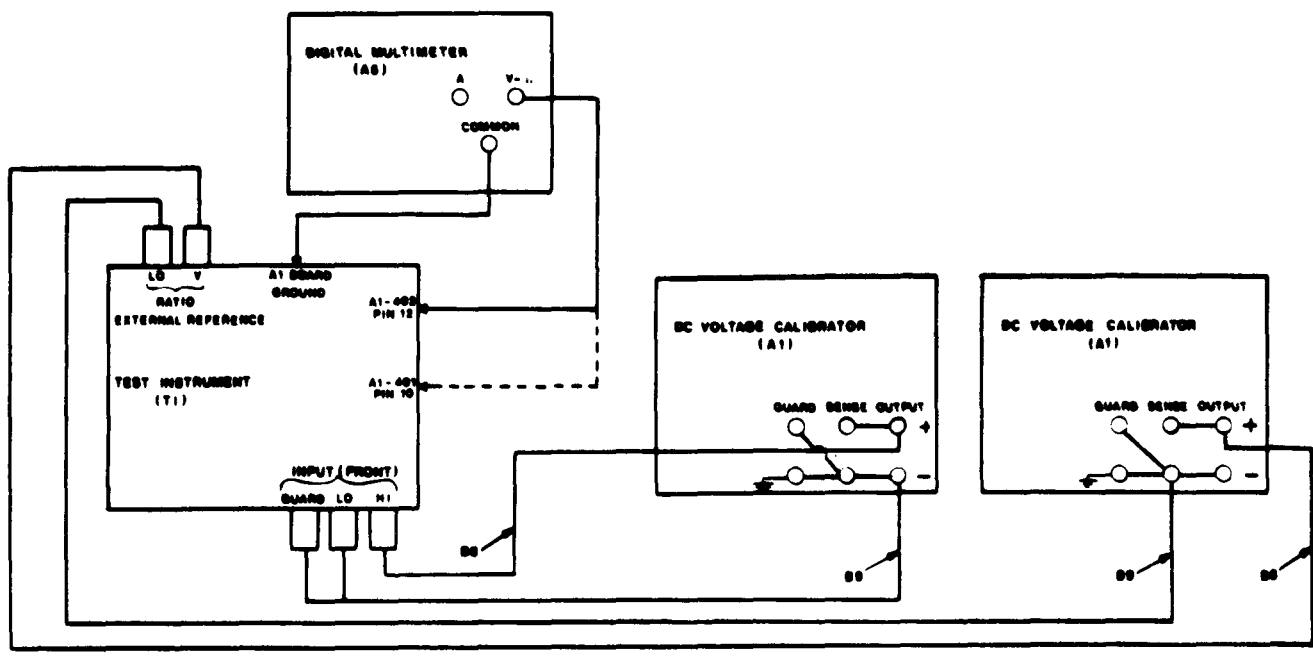

EL6U2051

Figure 6-26. DC/DC Ratio Autoranging, Equipment Connections

e. Ratio < -14000 Down Range Trip Point Adjustment (A1-R402)

(1) Continue with the same setup as in the previous step.

(2) Apply a -0.1400 Vdc signal to the voltmeter front panel INPUT terminals from the second dc voltage calibrator.

(3) Adjust A1-R402 until the voltage measured by the digital multimeter just trips from approximately -15.0 Vdc to approximately +5.0 Vdc.

(4) Increase the voltage applied to the voltmeter front panel INPUT terminals to -0.1500 Vdc.

(5) observe that the voltage measured by the digital multimeter is approximately -15.0 Vdc.

(6) Reduce the voltage applied to the voltmeter front panel INPUT terminals to -0.1300 Vdc.

(7) Observe that the voltage measured by the digital multimeter is approximately +5.0 Vdc.

6-20. Ac Volts Accuracy Adjustments

a. Zero Drift Temperature Compensation Adjustment (A7-R30). Refer to figure 6-27 for location of adjustments.

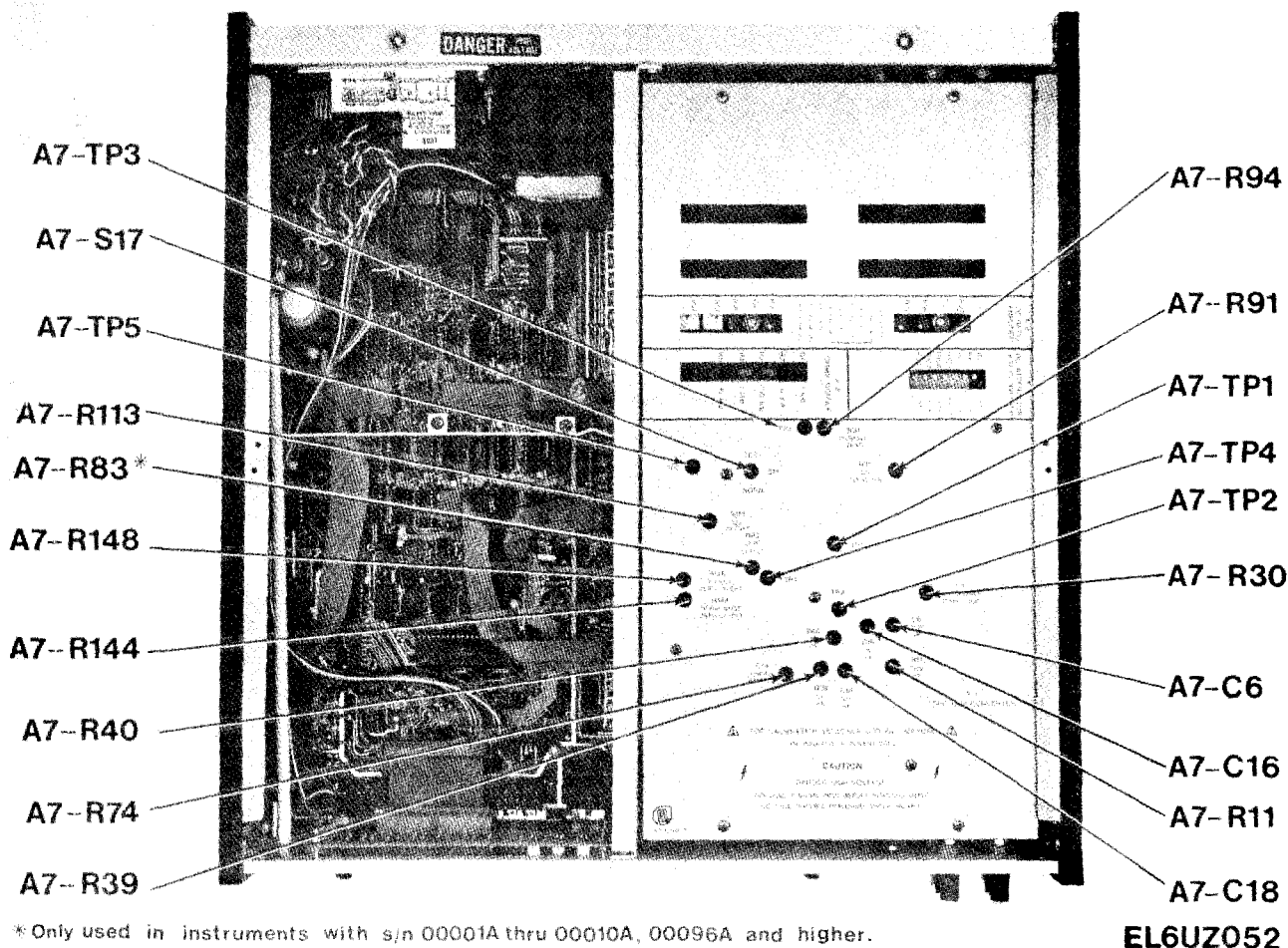

Figure 6-27. Location of Adjustments, True Rms Board

(1) Connect the equipment as shown in figure 6-28.

NOTE

It is not necessary to connect the oscilloscope (A6) at this time.

(2) Select the 2 V range and AC + DC VOLTS function on the voltmeter. All other buttons should be released to the "out" position.

(3) Set the front panel AC NULL control to the center of its mechanical rotation. To do this, first turn the control completely clockwise until an audible click is heard. Then, rotate the control counterclockwise ten complete turns.

(4) Remove the Top Guard Cage Cover.

(5) Select the 1 V range and .01 V NULL sensitivity on the differential voltmeter (A3) and set its dials +0.0000. This provides a meter indication of ± 0.01 V full scale on the dc differential voltmeter and corresponds to a count of ± 1000 on the voltmeter. Each major division on the dc differential voltmeter is then equivalent to ± 100 counts on the voltmeter.

(6) If the NULL indication on the differential voltmeter is greater than ± 0.001 V (100 counts) it will be necessary to increase or decrease the value of either A7-R17 or A7-R25, or both. When the reading is less than ± 0.001 V proceed to step (7).

(7) Apply the tip of a heated 60 watt soldering iron to the top of transistor A7-Q4 for about 5 seconds. At the end of this time, remove the soldering iron and observe the magnitude and direction of any change in reading on the dc differential voltmeter.

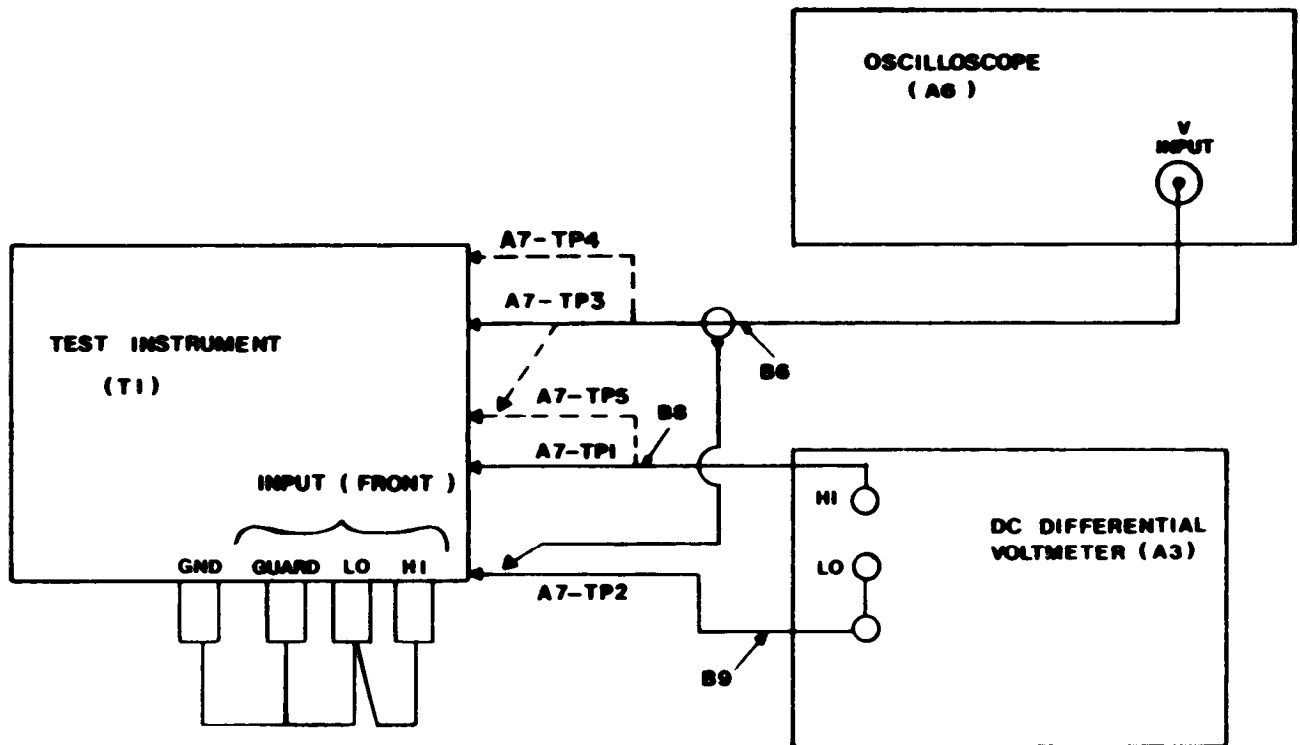

EL6UZ053

Figure 6-28. RMS Converter Adjustment, Equipment Connections

(8) If the drift is less than 50 counts from the "cold" reading, proceed to step b for voltmeter with serial prefix 00001A thru 00010A, 00096A and higher or step c for voltmeter with serial prefix 00011A thru 00039A, 00052A, 00055A and 00057A thru 00095A. If the drift is greater, continue with step a. (9).

(9) Adjust control A7-R30 for a reading on the dc differential voltmeter that is three times greater than the observed "hot" reading - in the same direction.

(10) Repeat step (6) through (8) as many times as required, until the drift is within the specified amount.

b. Overall Zero Adjustments (A7-R83, R94, R113, R144, R148). Applies to units with serial number 00001A thru 00010A, 00096A and higher.

(1) Connect the equipment as shown in figure 6-28.

(2) Select the 200 V range and AC VOLTS function on the voltmeter.

(3) Select the 1 V range and 100 μ V NULL sensitivity on the differential voltmeter (A3) and set its dials to +0.0000.

(4) Connect the dc differential voltmeter (A3) LO terminal to A7-TP2 on the voltmeter and connect the HI terminal to A7-TP1 on the voltmeter (see figure 6-28).

(5) Adjust the front panel AC NULL control on the voltmeter for a reading of zero (± 10 μ V) on the dc differential voltmeter.

(6) Disconnect the dc differential voltmeter HI test lead from A7-TP1 and connect it to A7-TP5 on the voltmeter.

(7) Adjust A7-R144 for a reading of zero (± 10 μ V) on the dc differential voltmeter.

NOTE

If the differential voltmeter indication tends to oscillate, adjust A7-R113 slowly counterclockwise until the oscillation stops. Re-adjust A7-R144 for a minimum reading on the differential voltmeter.

(8) Press the SLOW RESPONSE pushbutton to the "in" position. Adjust R148 for a minimum reading on the differential voltmeter (± 10 μ V). Allow a few minutes for the reading to settle after initial adjustment. If necessary, repeat the adjustment. Release the SLOW RESPONSE pushbutton back to the "out" position.

(9) Switch A7-S17 to the TEST position.

(10) Set the volts/div switch on the oscilloscope to the 5 mV position and select dc coupling. Set the time/div switch to 10 ms/div and set the probe switch to the REF position. Adjust the CH1 vertical position control to center the trace vertically.

(11) Set the oscilloscope probe switch to the X10 position and monitor the signal at TP3 as indicated in figure 6-28.

(12) Adjust A7-R94 for a zero dc indication (centered vertically) on the oscilloscope.

NOTE

The waveform may contain some component of noise. Adjust A7-R94 so that the waveform displayed is symmetrical vertically about the center horizontal graticule line.

(13) Change the oscilloscope probe to A7-TP4 and change the volts/div switch to 20 mV/div position. (Vertical sensitivity will now be 200 mV/div.

(14) Change the probe switch to the REF position and, if necessary, readjust the CH1 vertical position control to center the trace vertical-

ly on the oscilloscope. Change the probe switch back to the X10 position.

(15) Adjust A7-R83 so that the dc level of the signal displayed on the oscilloscope is -700 mV.

(16) There may be some interaction between the two adjustments. Repeat steps (10) through (15) until both requirements are satisfied.

(17) Set the differential voltmeter dials to -.0003 and set its drum dial to 50 (i.e. -350 uV).

(18) Adjust A7-R144 for zero null meter indication (± 50 uV) on the differential voltmeter.

(19) Disconnect the differential voltmeter from A7-TP5 and connect the oscilloscope probe in its place. Set switch A7-S17 to the NORM position.

(20) Change the oscilloscope volts/div switch back to 5 mV/div.

(21) Adjust A7-R 113 slowly clockwise until a low frequency oscillation just appears on the oscilloscope display. Rotate A7-R1 13 counterclockwise to the point where the oscillation just disappears.

(22) Set switch A7-S17 back to the TEST position and reconnect the differential voltmeter test lead to A7-TP5. Disconnect the oscilloscope probe from the test point.

(23) Set the differential voltmeter dials to +.0002 (i.e. +200 uV). Adjust A7-R 144 for zero null meter indication (± 50 uV) on the differential voltmeter.

(24) Switch A7-S17 back to the NORM position. The differential voltmeter null reading should remain unchanged (± 50 uV).

c. Overall Zero Adjustments (A7-R94, R113, R144, R148). Applies to units with serial number 00011A thru 00039A, 00052A, 00055A and 00057A thru 00095A.

(1) Connect the equipment as shown in figure 6-28.

(2) Select the 200 V range and AC VOLTS function on the voltmeter.

(3) Select the 1 V range and 100 uV NULL sensitivity on the differential voltmeter (A3) and set its dials to +0.0000.

(4) Connect the dc differential voltmeter (A3) LO terminal to A7-TP2 on the voltmeter and connect the HI terminal to A7-TP1 on the voltmeter (see figure 6-28).

(5) Adjust the front panel AC NULL control on the voltmeter for reading of zero (± 10 uV) on the dc differential voltmeter.

(6) Disconnect the dc differential voltmeter HI test lead from A7-TP1 and connect it to A7-TP5 on the voltmeter.

(7) Adjust A7-R 144 for a reading of zero (± 10 uV) on the dc differential voltmeter.

NOTE

If the differential voltmeter indication tends to oscillate, adjust A7-R113 slowly counterclockwise until the oscillation stops. Readjust A7-R144 for a minimum reading on the differential voltmeter.

(8) Press the SLOW RESPONSE pushbutton to the "in" position. Adjust R148 for a minimum reading on the differential voltmeter (± 10 uV). Allow a few minutes for the reading to settle after initial adjustment. If necessary, repeat the adjustment. Release the SLOW RESPONSE pushbutton back to the "out" position.

(9) Switch A7-S17 to the TEST position.

(10) Set the volts/div switch on the oscilloscope to the 20 mV position and select dc coupling. Set the time/div switch to 10 ms/div and set the probe switch to the REF position. Adjust the CH1 vertical position control to center the trace vertically.

(11) Set the oscilloscope probe switch to the X10 position and monitor the signal at TP4 as indicated in figure 6-28. (Vertical sensitivity will be 200 mV/div.)

(12) Adjust A7-R94 so that the dc level of the signal displayed on the oscilloscope is between -500 and -700 mV.

NOTE

The waveform may contain some component of noise.

(13) Set the differential voltmeter dials to -.0003 and set its drum dial to 50 (i.e. -350 uV).

(14) Adjust A7-R144 for zero null meter indication (± 50 uV) on the differential voltmeter.

(15) Disconnect the differential voltmeter from A7-TP5 and connect the oscilloscope probe in its place. Set switch A7-S17 to the NORM position.

(16) Change the oscilloscope volts/div switch back to 5 mV/div.

(17) Adjust A7-R1 13 slowly clockwise until a low frequency oscillation just appears on the oscilloscope display. Rotate A7-R1 13 counterclockwise to the point where the oscillation just disappears.

(18) Set switch A7-S17 back to the TEST position and reconnect the differential voltmeter test lead to A7-TP5. Disconnect the oscilloscope probe from the test point.

(19) Set the differential voltmeter dials to +.0002 (i.e. +200 uV). Adjust A7-R144 for zero null meter indication (± 50 uV) on the differential voltmeter.

(20) Switch A7-S17 back to the NORM position. The differential voltmeter null reading should remain unchanged (± 50 uV).

d. Dc Turnover Adjustment (A7-R91). Applies to units with serial number 00001A thru 00010A, 00096A and higher.

(1) Maintain the equipment connections of the previous adjustment (step b).

(2) Select the 20 V range and AC + DC function on the voltmeter.

(3) Connect a shorting jumper (B7) between the front panel HI and LO INPUT terminals.

(4) Connect the differential voltmeter LO terminal to A7-TP2 and the HI terminal to A7-TP1.

(5) Adjust the front panel AC NULL control on the voltmeter for a reading of zero (± 10 uV) on the differential voltmeter.

(6) Disconnect the differential voltmeter from the voltmeter.

(7) Adjust A7-R144 for a display reading on the voltmeter of 0.00000.

(8) Remove the shorting jumper from the voltmeter INPUT terminals. Disconnect all equipment from the voltmeter.

(9) Connect the dc voltage calibrator (A1) to the voltmeter INPUT terminals. Connect the plus terminal from the calibrator to the voltmeter HI INPUT terminal and the minus terminal to the voltmeter LO INPUT terminal. Apply a -10.00 Vdc signal and observe the reading displayed on the voltmeter.

(10) Reverse the connections between the calibrator and voltmeter. Observe the reading displayed. Except for the polarity sign, it should be the same as that observed in step (9). If necessary, adjust A7-R91 until the reading is the same (± 1 count).

(11) Reverse the connections between the calibrator and voltmeter. Decrease the output signal from the calibrator to -0.1 volt. Observe

the display reading on the voltmeter.

(12) Reverse the connections between the calibrator and voltmeter and note the reading. The two readings should be the same (± 10 counts).

(13) If the two readings do not agree (± 10 counts), re-adjust A7-R94 until this requirement is satisfied.

(14) Adjust R83 for a display of .1000 (± 10 counts).

(15) If it was necessary to adjust A7-R83, R94, then repeat steps (1) through (14).

e. Dc Turnover Adjustment (A7-R91). Applies to units with serial number 00011A thru 00039A, 00052A, 00055A and 00057A thru 00095A.

(1) Maintain the equipment connections of the previous adjustment (step c).

(2) Select the 20 V range and AC + DC function on the voltmeter.

(3) Connect a shorting jumper (B7) between the front panel HI and LO INPUT terminals.

(4) Connect the differential voltmeter LO terminal to A7-TP2 and the HI terminal to A7-TP1.

(5) Adjust the front panel AC NULL control on the voltmeter for a reading of zero (± 10 uV) on the differential voltmeter.

(6) Disconnect the differential voltmeter from the voltmeter.

(7) Adjust A7-R144 for a display reading on the voltmeter of 0.00000.

(8) Remove the shorting jumper from the voltmeter INPUT terminals. Disconnect all equipment from the voltmeter.

(9) Connect the dc voltage calibrator (A1) to the voltmeter INPUT terminals. Connect the plus terminal from the calibrator to the voltmeter HI INPUT terminal and the minus terminal to the voltmeter LO INPUT terminal. Apply a -10.00 Vdc signal and observe the reading displayed on the voltmeter.

(10) Reverse the connections between the calibrator and voltmeter. Observe the reading displayed. Except for the polarity sign, it should be the same as that observed in step (9). If necessary, adjust A7-R91 until the reading is the same (± 1 count).

(11) Reverse the connections between the calibrator and voltmeter. Decrease the output signal from the calibrator to -1.00 volt. Observe the display reading on the voltmeter.

(12) Reverse the connections between the calibrator and voltmeter and note the reading. Except for the polarity, the two readings should be the same (± 50 counts).

(13) If the two readings do not agree (± 50 counts), re-adjust A7-R94 until this requirement is satisfied.

(14) If it was necessary to adjust A7-R94, then repeat steps (1) through (13).

f. Crest Factor Adjustment (A7-R74)

(1) Connect the equipment as shown in figure 6-29.

(2) Select the 2 V range and AC + DC function on the voltmeter. All other voltmeter pushbuttons (except POWER OFF/ON) should be released to the out position.

(3) On the pulse generator (A9), select a frequency of 5 kHz. Set the delay to 25 us and the pulse width to 25 ms. Set the output amplitude to minimum.

(4) On the ac/dc transfer standard (A8), select the STANDBY condition by pressing the PUSH TO ENABLE pushbutton. Set the RANGE VOLTS RMS switch to the 0.5 - 1 position and

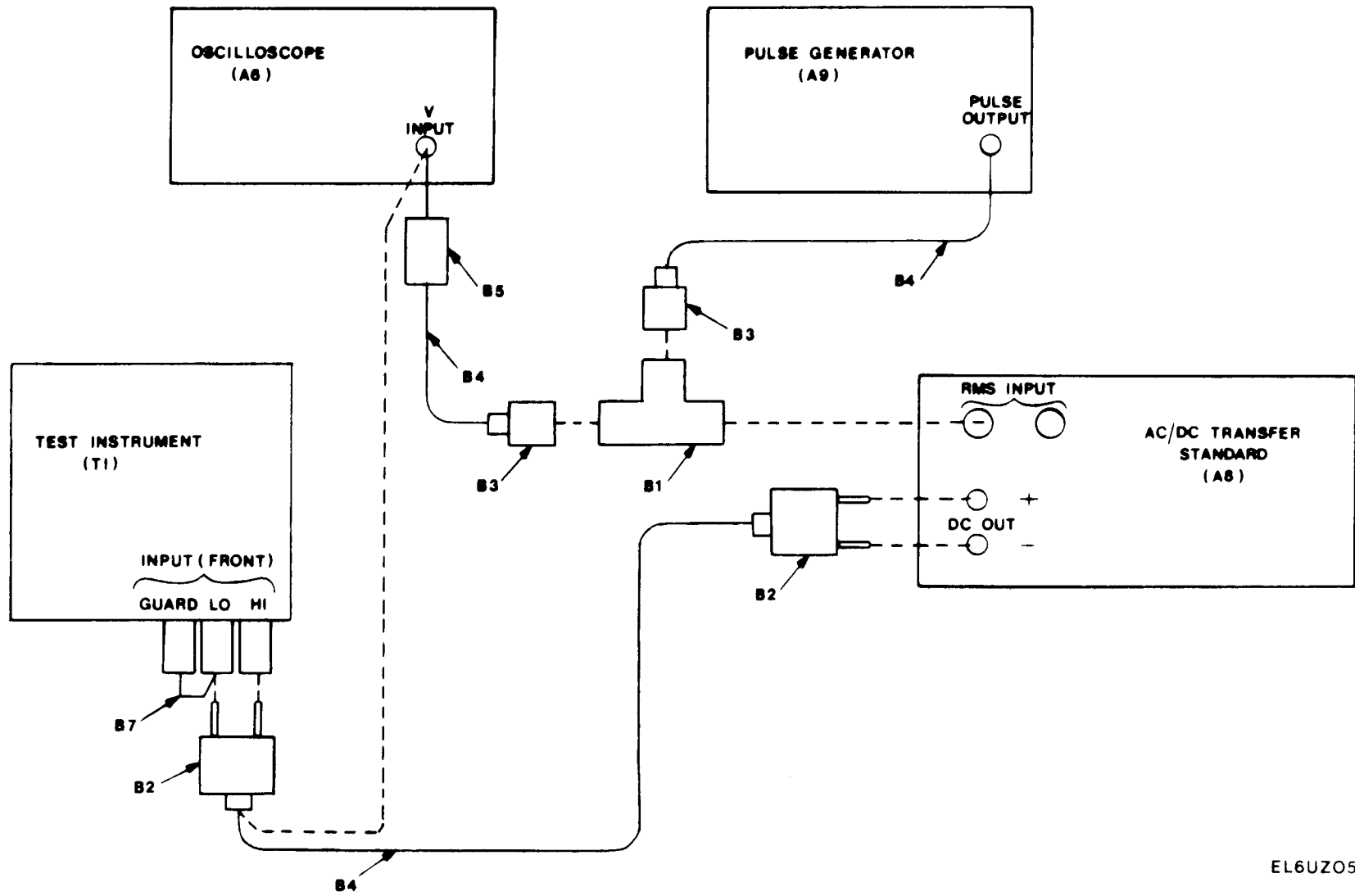

EL6UZ054

Figure 6-29. Crest Factor Adjustment, Equipment Connections

the mode switch to MANUAL TRANSFER. (If the DC lamp illuminates, press the TRANSFER RESET to select AC mode.) Press the PUSH TO RESET button.

(5) Set the oscilloscope (A6) VOLTS/DIV switch to the 1 volt position and the AC/DC coupling switch to the DC position. Select a TIME/DIV range of 1 ms.

(6) Adjust the pulse WIDTH and FREQUENCY on the pulse generator to obtain a mark-space ratio of 1:19 (0.5 division pulse, 9.5 division base line). The pulse amplitude should be about 3.8 volts peak-to-peak as observed on the oscilloscope.

(7) Adjust the pulse generator DELAY control and the oscilloscope TRIGGER LEVEL to obtain a stable display.

NOTE

The meter pointer on the ac/dc transfer standard should arrive at a balance condition (0 on BAL scale).

(8) Transfer the ac/dc transfer standard to DC by pressing the TRANSFER RESET button.

(9) Observe the reading displayed by the voltmeter. It should be about 0.8 volt. Record the value observed.

(10) Press the TRANSFER RESET button on the ac/dc transfer standard to transfer back to the AC mode.

(11) Disconnect the coax cable (B4) and 50 Ω termination (B5) from the oscilloscope and connect it to the voltmeter through the adapter (B2). It will be necessary to first disconnect the coax cable (B4) that was connected to the adapter (B2), at the voltmeter terminals.

(12) Adjust A7-R74 until the voltmeter indicates the same reading displayed in step (9).

(13) Disconnect the coax cable (B4) and 50 Ω termination (B5) from the adapter (B2) at the voltmeter.

(14) Reconnect the coax cable (B4) from the ac/dc transfer standard. DC OUT terminals to the adapter (B2) at the voltmeter.

(15) Transfer back to the DC mode by pressing the TRANSFER RESET button on the ac/dc transfer standard. Observe the reading indicated on the voltmeter.

NOTE

If the reading indicated by the voltmeter is different from the initial reading (step 9), the new reading now becomes the reference voltage.

(16) If a different reading was obtained in step (15), it will be necessary to repeat steps (10) through (15) until the high crest factor (pulse generator) and dc reading (ac/dc transfer standard) agree.

g. Rms Converter Dc Range Adjustments (A7-R40), A7-R39, A7-R11)

(1) Connect the equipment as shown in figure 6-30.

(2) Select the 2 V range and AC + DC function on the voltmeter. All other voltmeter pushbuttons (except POWER OFF/ON) should be released to the out position.

(3) Set the dc voltage calibrator (A1) to 1.9000 volts and observe the reading indicated on the voltmeter.

NOTE

An Ac Voltage Calibrator set to 400 Hz may be substituted for the Dc Voltage Calibrator.

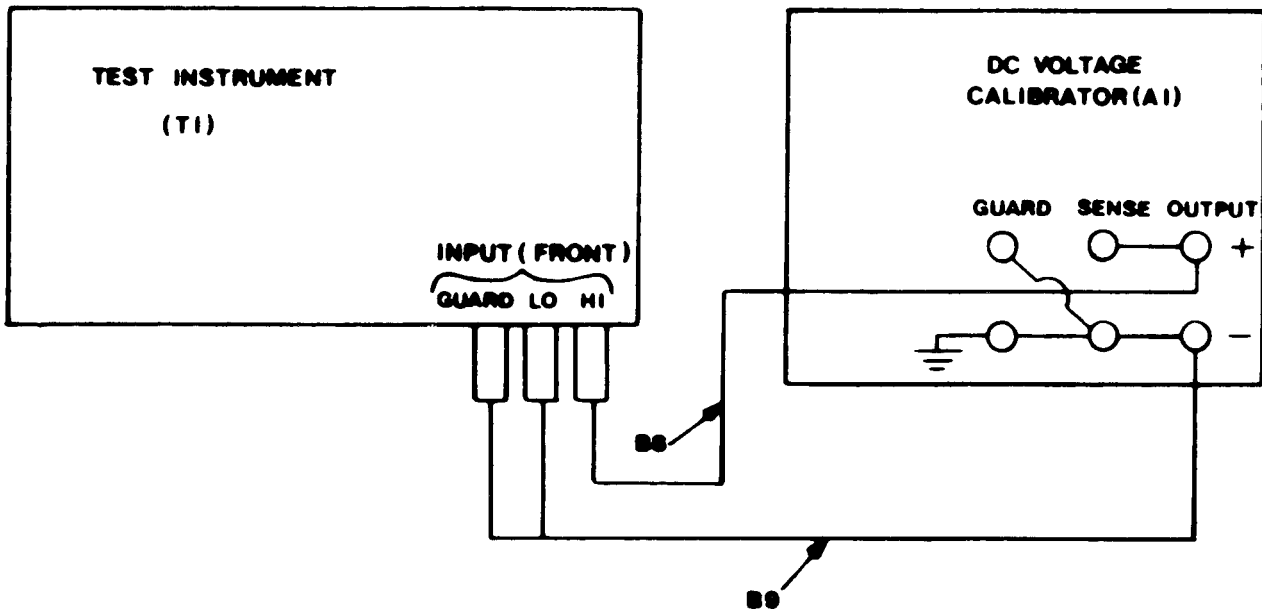

EL6UZ055

Figure 6-30. DC Volts Accuracy, Equipment Connections

(4) Refer to table 6-9 and, if required, adjust A7-R40 until the reading displayed by the voltmeter is within the tolerance specified by the table.

of the voltmeter and again refer to table 6-9. If the readings indicated on the voltmeter are not within the tolerances specified, adjust the respective calibration control.

(5) Proceed to the 20 V and 200 V ranges

Table 6-9. Rms Converter Dc Range Checks

Voltmeter Range	Dc Voltage Calibrator (A1) Setting (Volts)	Voltmeter Adjustment	Voltmeter Display Tolerance
2 V	+1.90000	A7-R40	1.90000 ± 0.00005
20 V	+19.0000	A7-R39	19.0000 ± 0.0005
200 V	+190.000	A7-R11	190.000 ± 0.005

h. Rms Converter Ac Range Adjustments(A7-C16, A7-C18, A7-C6)

(1) Connect the equipment as shown in figure 6-31.

(2) Select the 2 V range and AC + DC function on the voltmeter. All other voltmeter pushbuttons (except POWER OFF/ON) should be released to the out position.

(3) Set the ac voltage calibrator (A2) to 1.90000 volt and set the test frequency of the

calibrator to 25 kHz. Observe the reading indicated on the voltmeter.

(4) Refer to table 6-10 and, if required, adjust A7-C 16 until the reading displayed by the voltmeter is within the tolerance specified by the table.

(5) Proceed to the 20 V and 200 V ranges of the voltmeter and again refer to table 6-10. If the readings are not within the tolerance specified, adjust the respective calibrator control.

Table 6-10. Rms Converter Ac Range Checks

Voltmeter Range	Dc Voltage Calibrator (A2) Setting (Volts)	Voltmeter Adjustment	Voltmeter Display Tolerance
2 V	1.90000	A7-C16	1.90000 ± 0.00010
20 V	19.0000	A7-C18	19.0000 ± 0.0010
200 V	190.000	A7-C6	190.000 ± 0.010

6-21. Final Procedure

De-energize all equipment and disconnect all

test leads. Re-install all covers on the voltmeter.

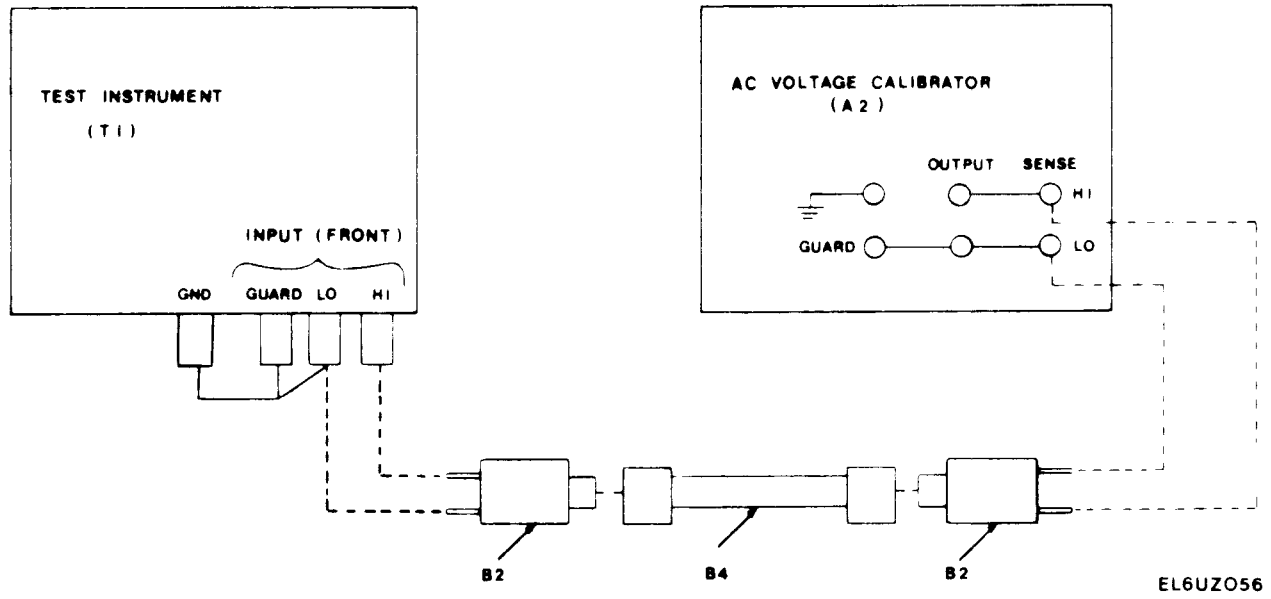

Figure 6-31. AC Volts Accuracy Check, Equipment Connections

APPENDIX A

REFERENCES

DA Pam 25-30	Consolidated Index of Army Publications and Blank Forms.
DA Pam 750-8	The Army Maintenance Management System (TAMMS) Users Manual.
MIL-HDBK-454A	Operation's General Guidelines for Electronic Equipment.
TM 9-4931 -383-14-1	Operator's, Organizational, Direct Support and General Support Maintenance Manual, Including Repair Parts and Special Tools List, DC Voltage Calibrator John Fluke Models 332B/AF and 332 B/D (NSN 6625-00-150-6994).
TM 11-6625-623-12	Organizational Maintenance Manual (Including Repair Parts and Special Tools Lists) Maintenance Kit Electronic Equipment, MK-722/-URC (NSN 5999-00-757-7042).
TM 11-6625-1548-15	Organizational, DC, GS and Depot Maintenance Manual Counter Electronic Digital CP-772/U/ Hewlett-Packard Model 5245L.
TM 11-6625-2953-14	Operator's, Organizational, Direct Support and General Support Maintenance Manual: Multimeter AN/USM-451 (NSN 6625-01-060-6804).
TM 750-244-2	Procedures for Destruction of Electronics Materiel to Prevent Enemy Use (Electronics Command).

APPENDIX B

MAINTENANCE ALLOCATION

Section I. INTRODUCTION

B-1. General

This appendix provides a summary of the maintenance operations for AN/GSM-64C. It authorizes categories of maintenance for specific maintenance functions on repairable items and components and the tools and equipment required to perform each function. This appendix may be used as an aid in planning maintenance operations.

B-2. Maintenance Function

Maintenance functions will be limited to and defined as follows:

- a. Inspect.** To determine the serviceability of an item by comparing its physical, mechanical, and/or electrical characteristics with established standards through examination.
- b. Test.** To verify serviceability and to detect incipient failure by measuring the mechanical or electrical characteristics of an item and comparing those characteristics with prescribed standards.
- c. Service.** Operations required periodically to keep an item in proper operating condition; i.e., to clean, preserve, drain, paint, or to replenish fuel/lubricants/hydraulic fluids or compressed air supplies.
- d. Adjust.** Maintain within prescribed limits by bringing into proper or exact position, or by setting the operating characteristics to the specified parameters.
- e. Align.** To adjust specified variable elements of an item to about optimum or desired performance.
- f. Calibrate.** To determine and cause corrections to be made or to be adjusted on instruments or test measuring and diagnostic equipment used in precision measurement. Consists of the comparison of two instruments, one of which is a certified standard of known accuracy, to detect and adjust any discrepancy in the accuracy of the instrument being compared.
- g. Install.** The act of emplacing, seating, or fixing into position an item, part, module (component or assembly) in a manner to allow the proper functioning of the equipment/system.
- h. Replace.** The act of substituting a serviceable like-type part, subassembly, module (component or assembly) for an unserviceable counterpart.
- i. Repair.** The application of maintenance services (inspect, test, service, adjust, align, calibrate, replace) or other maintenance actions (welding, grinding, riveting, straightening, facing, remachining, or resurfacing) to restore serviceability to an item by correcting specific damage, fault, malfunction, or failure in a part, subassembly, module/component/assembly, end item or system.
- j. Overhaul.** That periodic maintenance effort (service/action) necessary to restore an item to a completely serviceable/operational condition as prescribed by maintenance standards (e.g., DWR) in appropriate technical publications. Overhaul is normally the highest degree of maintenance performed by the Army. Overhaul does not normally return an item to like-new condition.
- k. Rebuild.** Consists of those services/-actions necessary for the restoration of unservice-

able equipment to a like-new condition in accordance with original manufacturing standards. Rebuild is the highest degree of materiel maintenance applied to Army equipment. The rebuild operation includes the act of returning to zero those age measurements (hours, miles, etc.) considered in classifying Army equipment/components.

B-3. Column Entries

a. Column 1, Group Number. Column 1 lists group numbers, the purpose of which is to identify components, assemblies, subassemblies, and modules with the next higher assembly.

b. Column 2, Component/Assembly. Column 2 contains the noun names of components, assemblies, subassemblies, and modules for which maintenance is authorized.

c. Column 3, Maintenance Functions. Column 3 lists the functions to be performed on the item listed in column 2.

d. Column 4, Maintenance Category. Column 4 specifies, by the listing of a "worktime" figure in the appropriate subcolumn(s), the lowest level of maintenance authorized to perform the function listed in column 3. This figure represents the active time required to perform that maintenance function at the indicated category of maintenance. If the number or complexity of the tasks within the listed maintenance function vary at different maintenance categories, appropriate "work time" figures will be shown for each category. The number of man-hours specified by the "worktime" figure represents the average time required to restore an item (assembly, subassembly, component, module, end item or system) to a serviceable condition under typical field operating conditions. This time includes preparation time, troubleshooting time, and

quality assurance/quality control time in addition to the time required to perform the specific tasks identified for the maintenance functions authorized in the maintenance allocation chart. Subcolumns of column 4 are as follows:

- C** - Operator/Crew **H** - General Support
- O** - Organizational **D** - Depot
- F** - Direct Support

e. Column 5, Tools and Equipment. Column 5 specifies by code, those common tool sets (not individual tools) and special tools, test, and support equipment required to perform the designated function.

B-4. Tool and Test Equipment Requirements

a. Tool or Test Equipment Reference Code. The numbers in this column coincide with the numbers used in the tools and equipment column of the MAC. The numbers indicate the applicable tool or test equipment for the maintenance functions.

b. Maintenance Category. The codes in this column indicate the maintenance category allocated the tool or test equipment.

c. Nomenclature. This column lists the noun name and nomenclature of the tools and test equipment required to perform the maintenance functions.

d. National / NATO Stock Number. This column lists the National/NATO stock number of the specific tool or test equipment.

e. Tool Number. This column lists the manufacturer's part number followed by the Federal supply code for manufacturer (5-digit) in parentheses.

**Section II. MAINTENANCE ALLOCATION CHART FOR
VOLTMETER AN/GSM-64C**

(1) GROUP NUMBER	(2) COMPONENT/ASSEMBLY	(3) MAINTENANCE FUNCTION	(4) MAINTENANCE CATEGORY					(5) TOOLS AND EQPT.	(6) REMARK:
			C	O	F	H	D		
01	Voltmeter, Digital AN/GSM-64C	Inspect Test Repair Replace Calibrate Overhaul		0.5		1 1.5 0.7 1.8		1,2,3,5 7,8 7,8 1,2,4,5 1-9	A C
0101	PCB, Digital Circuit Board A2)	Inspect Test Repair Replace Calibrate			D.3	1 1.2 3 0.5		5,6 7,8 7,8 1,2,4,5	A B C
0102	PCB, Analog Circuit Board A1)	Inspect Test Repair Replace Calibrate			D.5	1.2 1.2 3 1.8		5,6 7,8 7,8 1,2,4,5	A B C
010201	Module, Dc to Digital Converter	Inspect Test Replace			0.1	0.3 0.1		5,6 7,8	A B *
0103	PCB, Display A3)	Inspect Test Replace Repair		0.1		0.3 0.7 0.3		6 7,8 7,8	A B
0104	Rear Panel Assembly A5)	Inspect Test Replace Repair		0.1		0.2 1.2 0.4		5,6 7,8 7,8	A B
0105	Front Panel Assembly A4)	Inspect Repair Replace		0.1		0.2 0.7		7,8 7,8	A
02	PCB, Ac to Dc Converter A7)	Inspect Test Repair Replace Calibrate			0.2	0.5 0.8 0.2 0.6		5,6 7,8 7,8 1,2,8	A B C
03	PCB, Dc Ratio A9)	Inspect Test Repair Replace Calibrate			0.3	0.5 0.5 0.1 1.1		5,6 7,8 7,8 1,6	A B C

*Dc to Digital Converter added for completeness

REMARKS

REFERENCE CODE	REMARKS
A	Visual
B	Verify Performance
C	Verify accuracy as compared to calibration standard

**Section III. TOOL AND TEST EQUIPMENT REQUIREMENTS FOR
DIGITAL VOLTMETER, AN/GSM-64C**

TOOL OR TEST EQUIPMENT REF CODE	MAINTENANCE CATEGORY	NOMENCLATURE	NATIONAL/NATO STOCK NUMBER
1	H,D	John Fluke Mdl 3326 Dc Voltage Std.	6625-00-150-6994
2	H,D	John Fluke Mdl 5200A/5215A Ac Voltage Calib.	6625-01-063-6325
3	H,D	Oscilloscope H.P. 180D	6625-00-022-8228
4	H,D	Transformer, Variable Gen Rad W10MT3AS3	6120-00-168-3705
5	H,D	Frequency Counter CP-772A/U	6625-00-973-4837
6	H,D	Multimeter AN/USM-451	6625-01-060-6804
7	H,D	Maintenance Kit MK-772/U	5999-00-757-7042
8	H,D	Tool Kit TK-100/G	5180-00-605-0079
9	D	Tools and Test Equipment as authorized to the repairman user because of his assigned task.	

* Factory Selected Component Chart

Figure No. Schematic	Ref. Desig.	Nominal Value	Min.	Max.	Assoc. with	
FO-2	R26	1.21 MΩ	1 MΩ	Open	R106	-1V FR Adj.
FO-3	C7	33 pf	27 pf	39 pf	C6	100V/HF/AC Adj.
FO-3	C62	22 pf	18 pf	27 pf	C6	100V/HF/AC Adj.
FO-3	R17	Open	100 KΩ	Open	R23	1 mV Null Adj.
FO-3	C60	82 pf	68 pf	100 pf	C18	10V/HF/AC Adj.
FO-3	C17	22 pf	27 pf	18 pf	C18	10V/HF/AC Adj.
FO-3	C15	33 pf	27 pf	39 pf	C16	1V/HF/AC Adj.
FO-3	R25	Open	100 KΩ	Open	R23	1mV Null Adj.
FO-4	R110	12.1 KΩ	6.82 KΩ	16.8 KΩ	---	AC Linearity Selection
FO-4	R117	178 KΩ	120 KΩ	430 KΩ	R116	FS Sensitivity
FO-4	R147	3.3 MΩ	0	10 MΩ	R148	LF Zero Offset Adj.
FO-5	C3	Open	68 pf	Open	C4	60Hz CM
FO-5	R6	22 KΩ	27 KΩ	18 KΩ	R3	10V FR Adj.
FO-5	R9	1.5 KΩ	2.4 KΩ	.680 KΩ	R10	100V FR Adj.
FO-5	R16	22 KΩ	27 KΩ	18 KΩ	R13	10V DC CM
FO-5	R21	1.5 KΩ	2.4 KΩ	.68 KΩ	R22	100V DC CM
FO-5	C8	Open	68 pF	Open	C6	60Hz CM

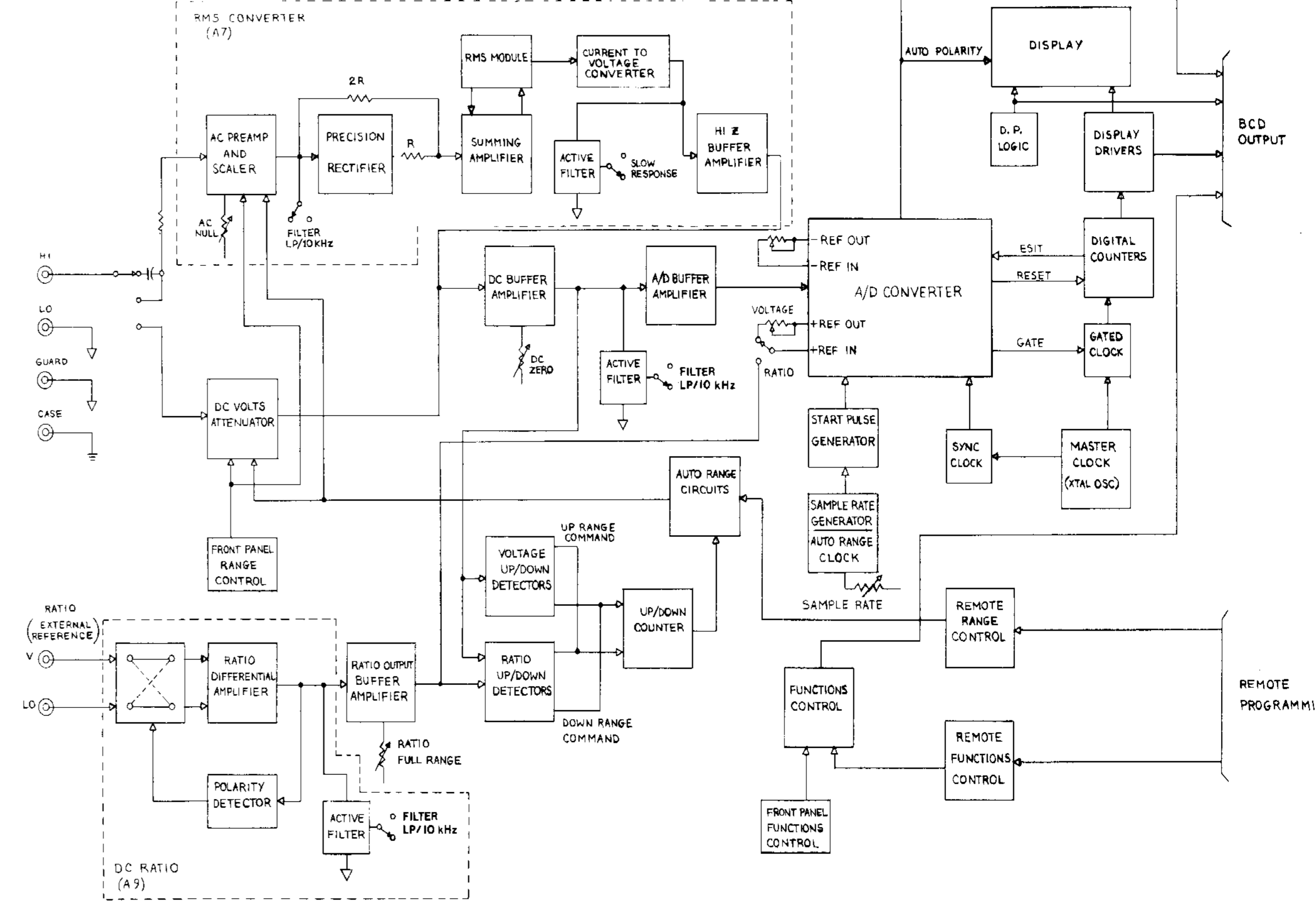
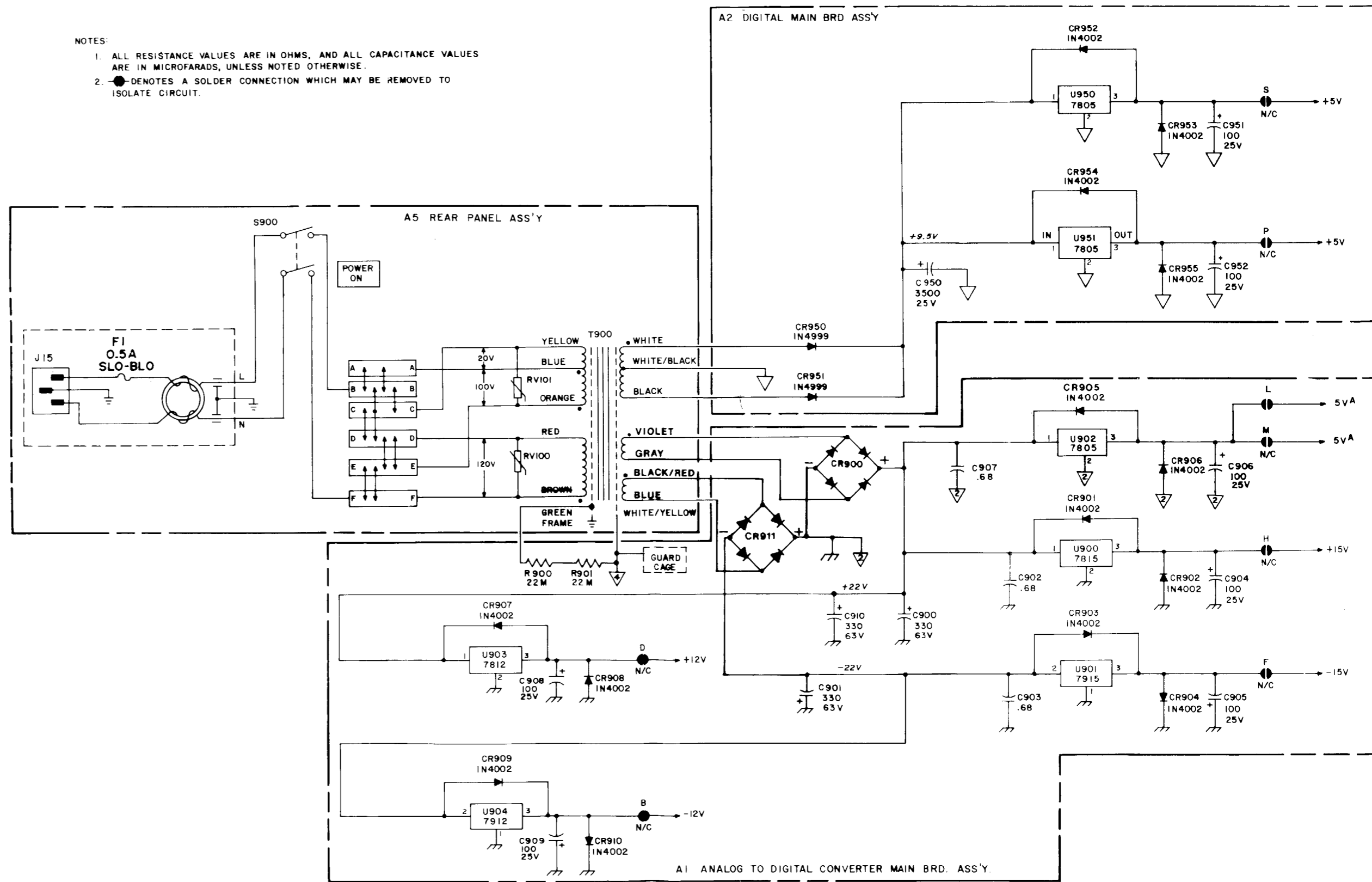

Figure FO-1. Voltmeter Block Diagram

- NOTES:
1. ALL RESISTANCE VALUES ARE IN OHMS, AND ALL CAPACITANCE VALUES ARE IN MICROFARADS, UNLESS NOTED OTHERWISE.
 2. ● DENOTES A SOLDER CONNECTION WHICH MAY BE REMOVED TO ISOLATE CIRCUIT.



EL6UZO28

Figure FO-2. Power Supply (A1,A2) Schematic Diagram

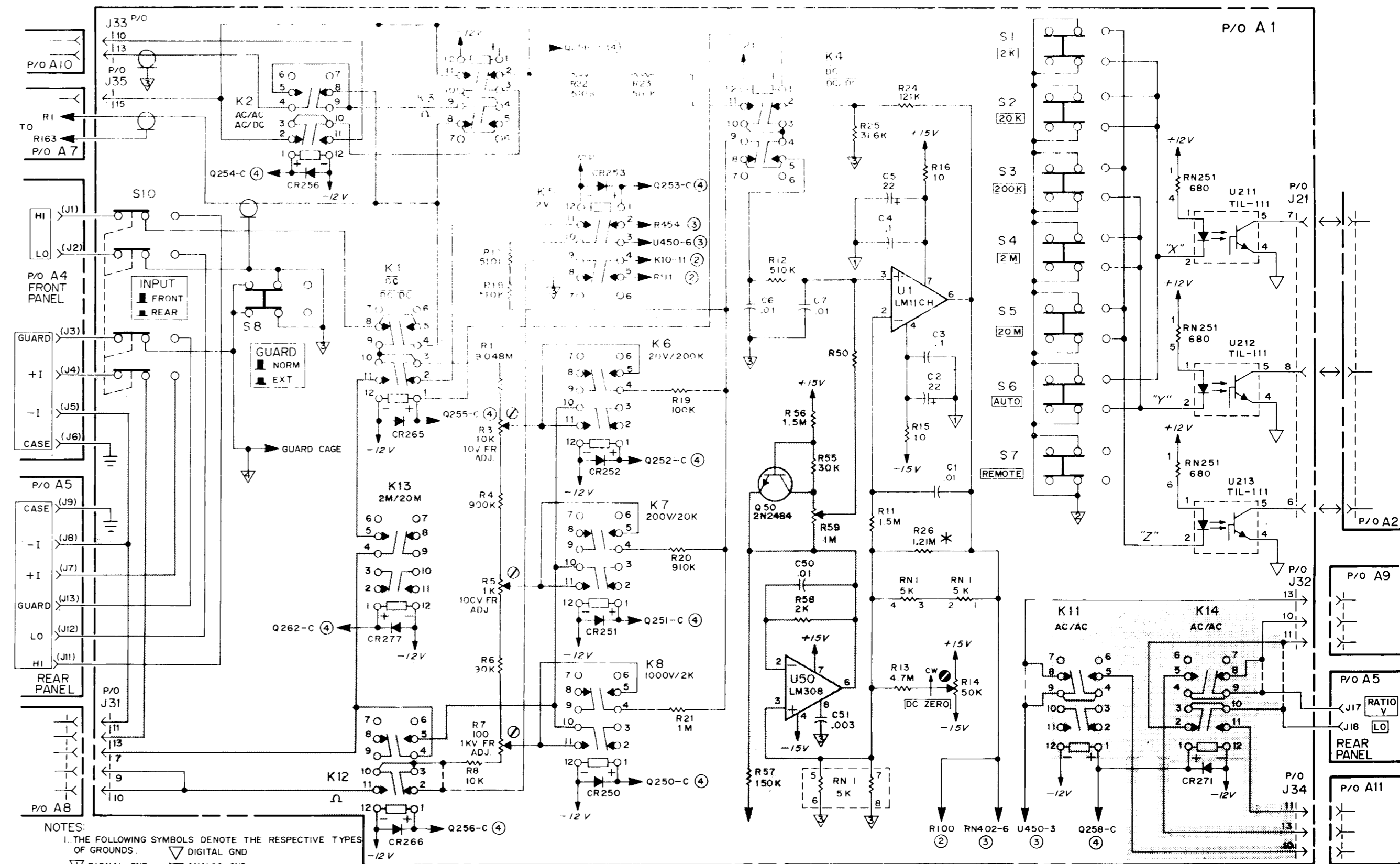

- NOTES:
1. THE FOLLOWING SYMBOLS DENOTE THE RESPECTIVE TYPES OF GROUNDS:
 ▽ SIGNAL GND ▽ ANALOG GND
 ▽ DIGITAL GND ▽ SIGNAL COMMON ▽ GUARD CAGE
 2. ALL DIODES ARE TYPE IN4148, UNLESS OTHERWISE NOTED.
 3. DOTTED LINES BYPASS UNUSED OPTION RELAYS.
 4. * DENOTES FACTORY SELECT VALUE.
 5. SHEET DESIGNATIONS ARE AS FOLLOWS:
 (1) SHEET 1 ; (2) SHEET 2 ; (3) SHEET 3 ; (4) SHEET 4
 6. ALL CAPACITOR AND RESISTOR VALUES ARE IN MICROFARADS AND OHMS RESPECTIVELY, UNLESS OTHERWISE NOTED.

Figure FO-3. Dc Volts Attenuator/Analog Switching (AI) Schematic Diagram

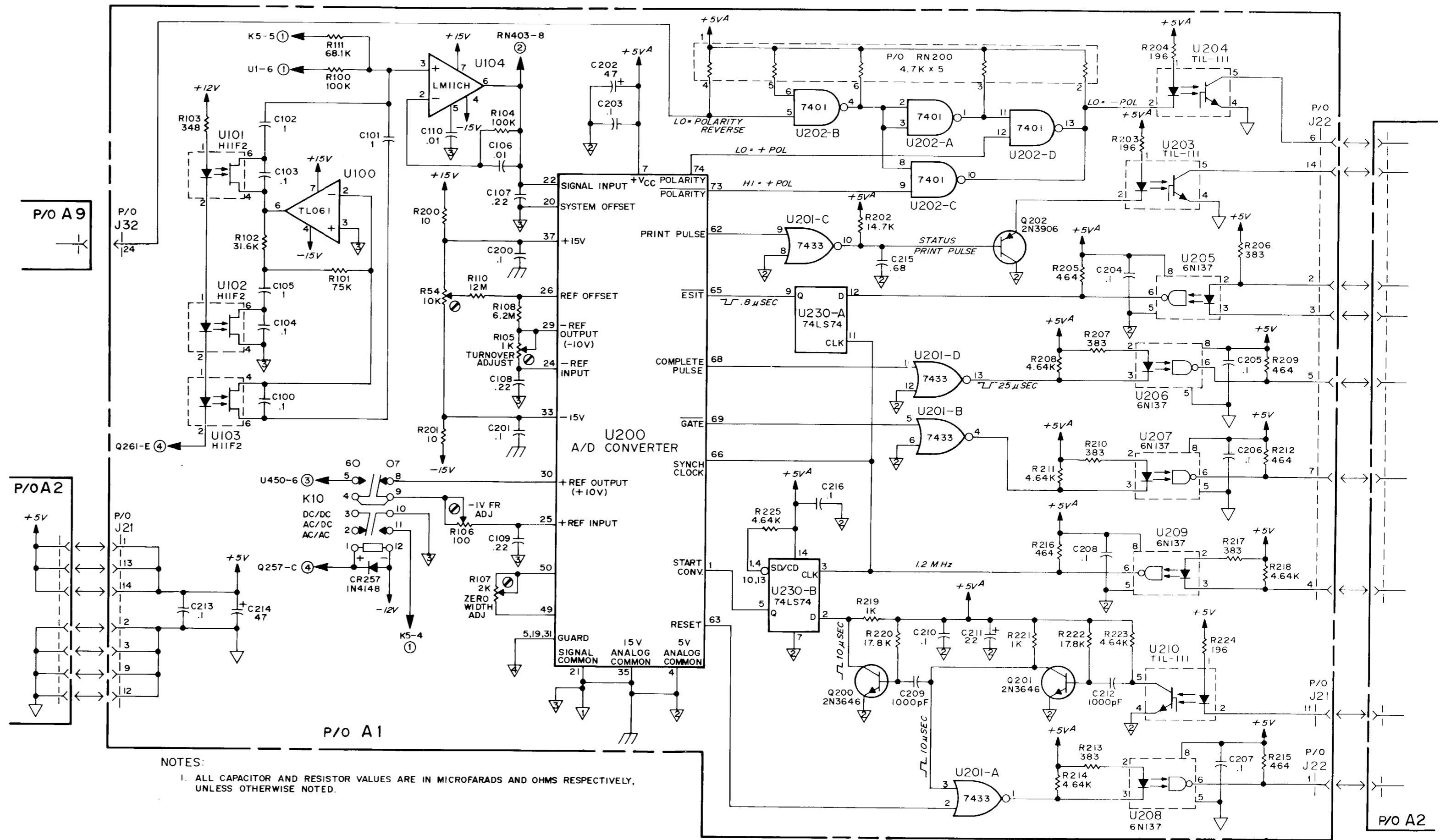

Figure FO-4. A/D Converter and Active Filter (A1) Schematic Diagram

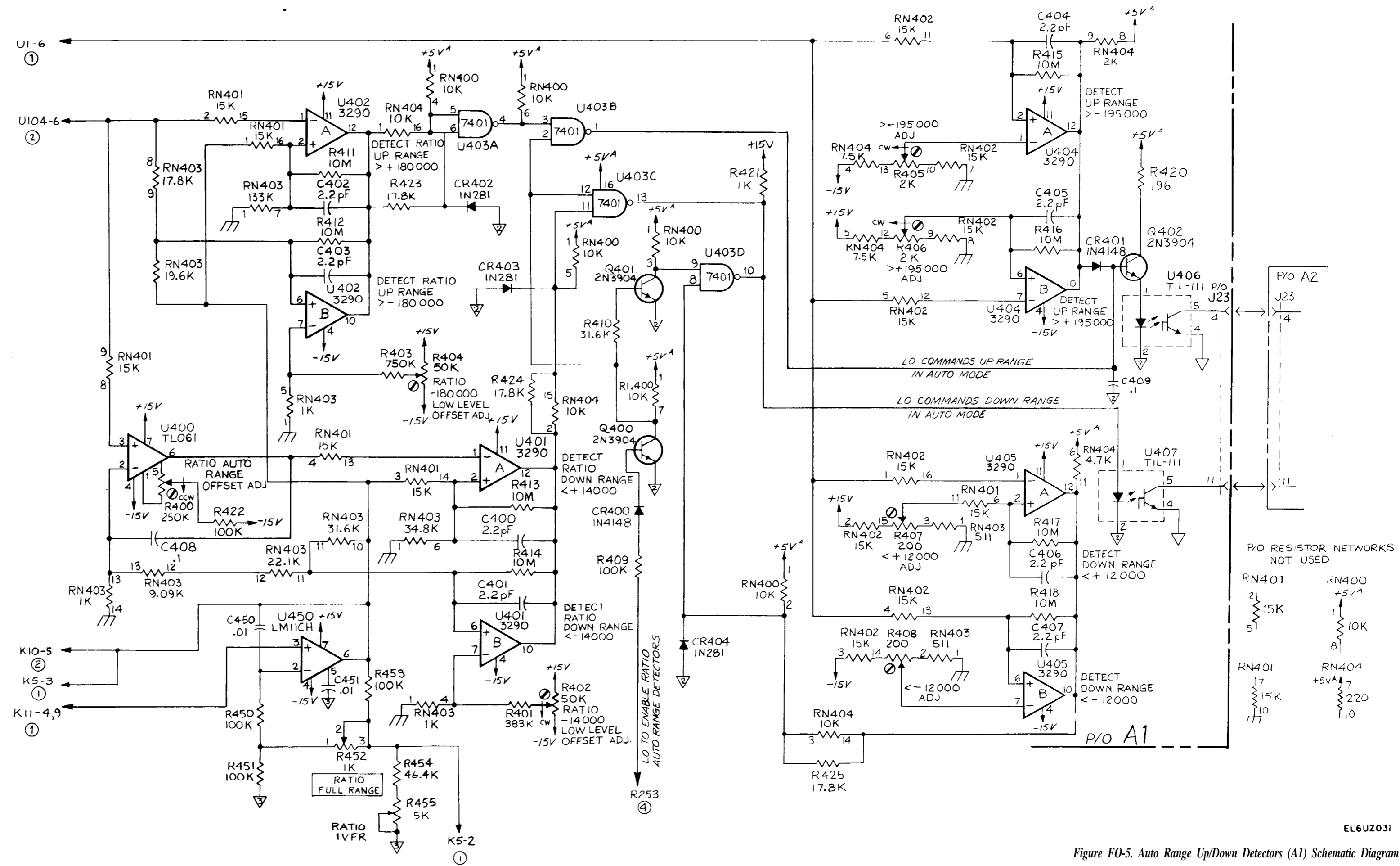

Figure FO-5. Auto Range Up/Down Detectors (A1) Schematic Diagram

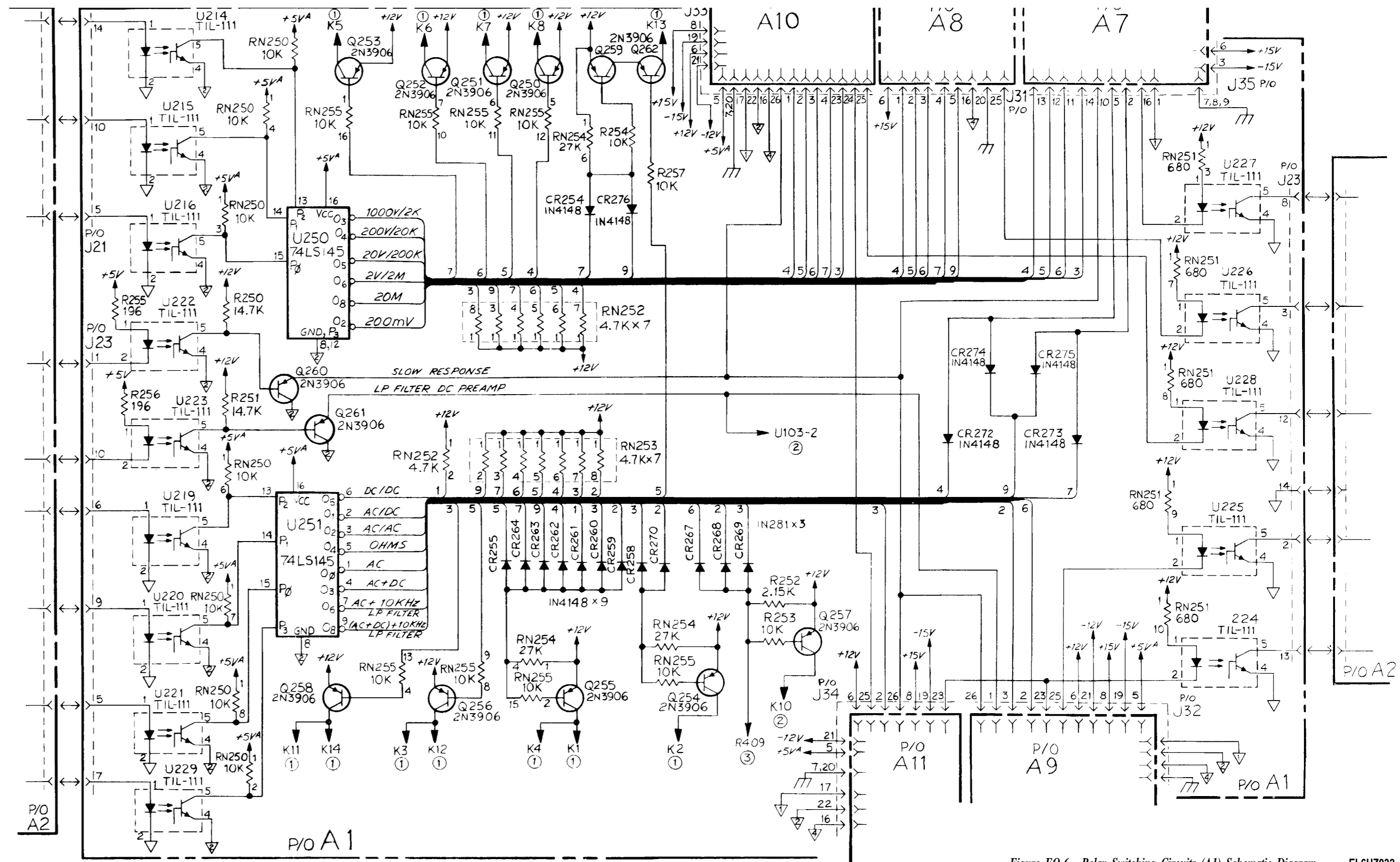

Figure FO-6. Relay Switching Circuits (A1) Schematic Diagram EL6UZ032

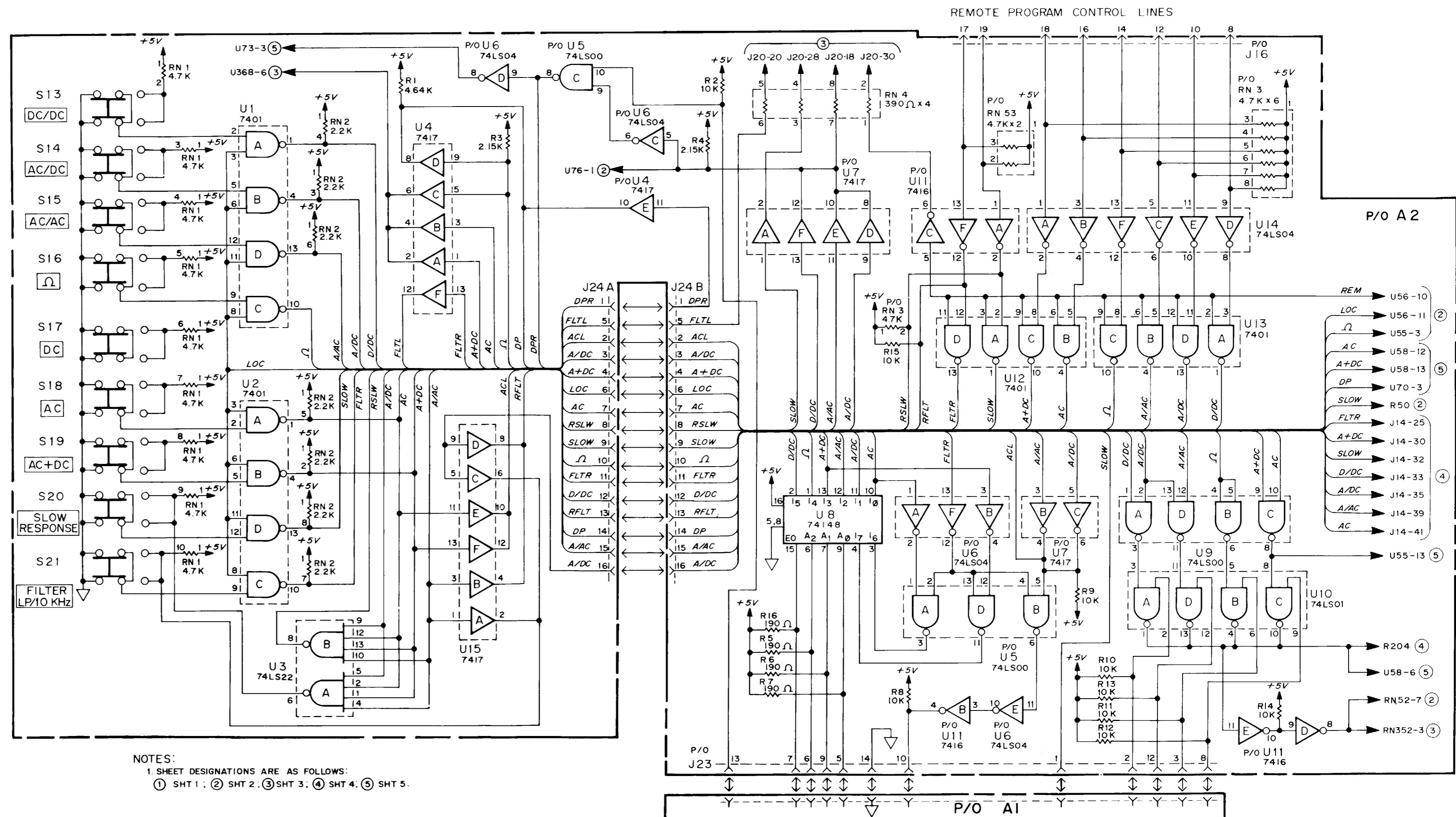
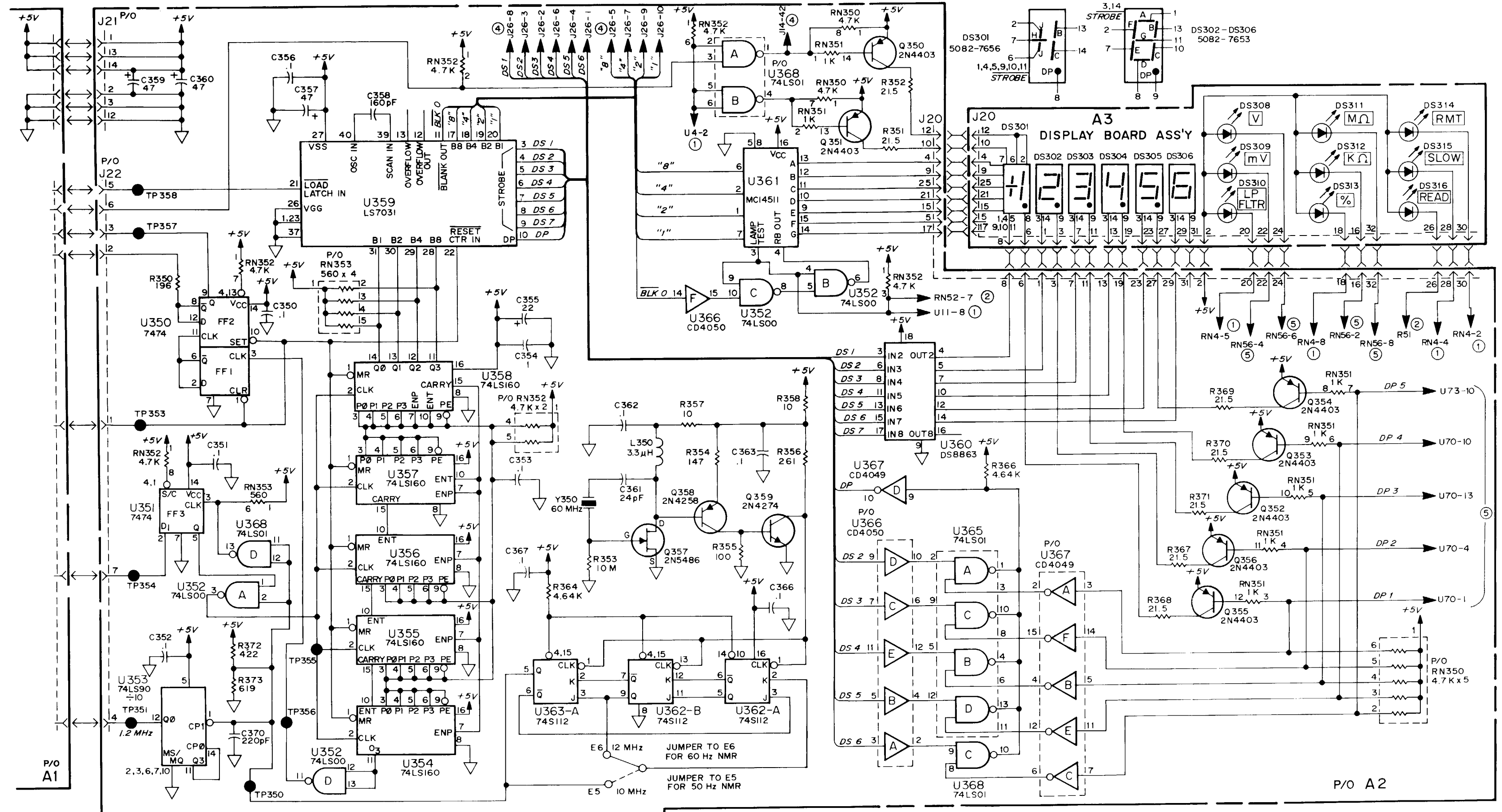

Figure FO-7. Function Select Logic (A2) Schematic Diagram



NOTE:
 1. ALL CAPACITOR AND RESISTOR VALUES ARE IN MICROFARADS AND OHMS RESPECTIVELY, UNLESS OTHERWISE NOTED.

Figure FO 9. Counters and Display Circuits (A2,A3) Schematic Diagram

PARALLEL BCD OUTPUT

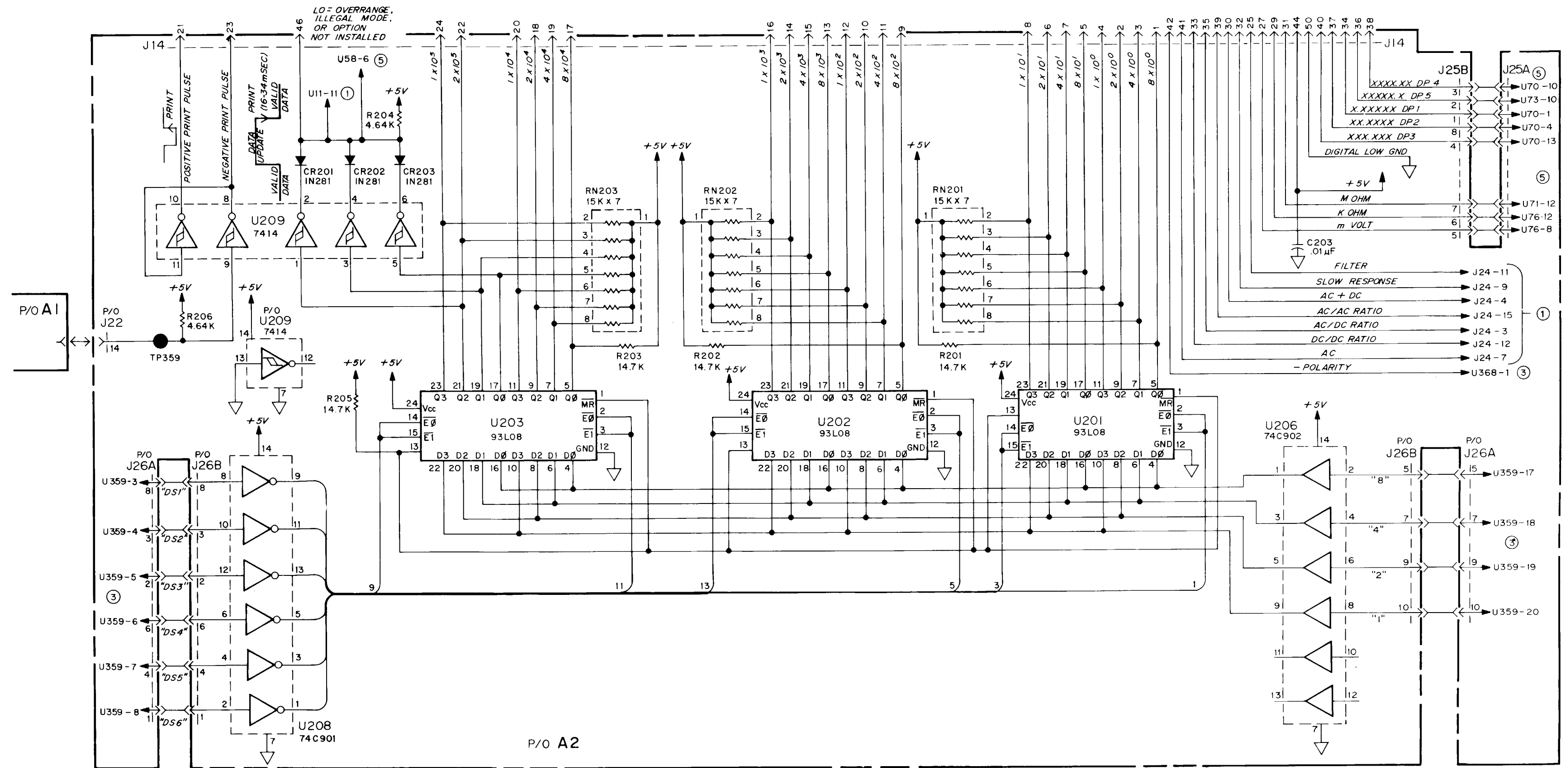

EL6U2036

Figure FO-10. Parallel BCD Output (A2) Schematic Diagram

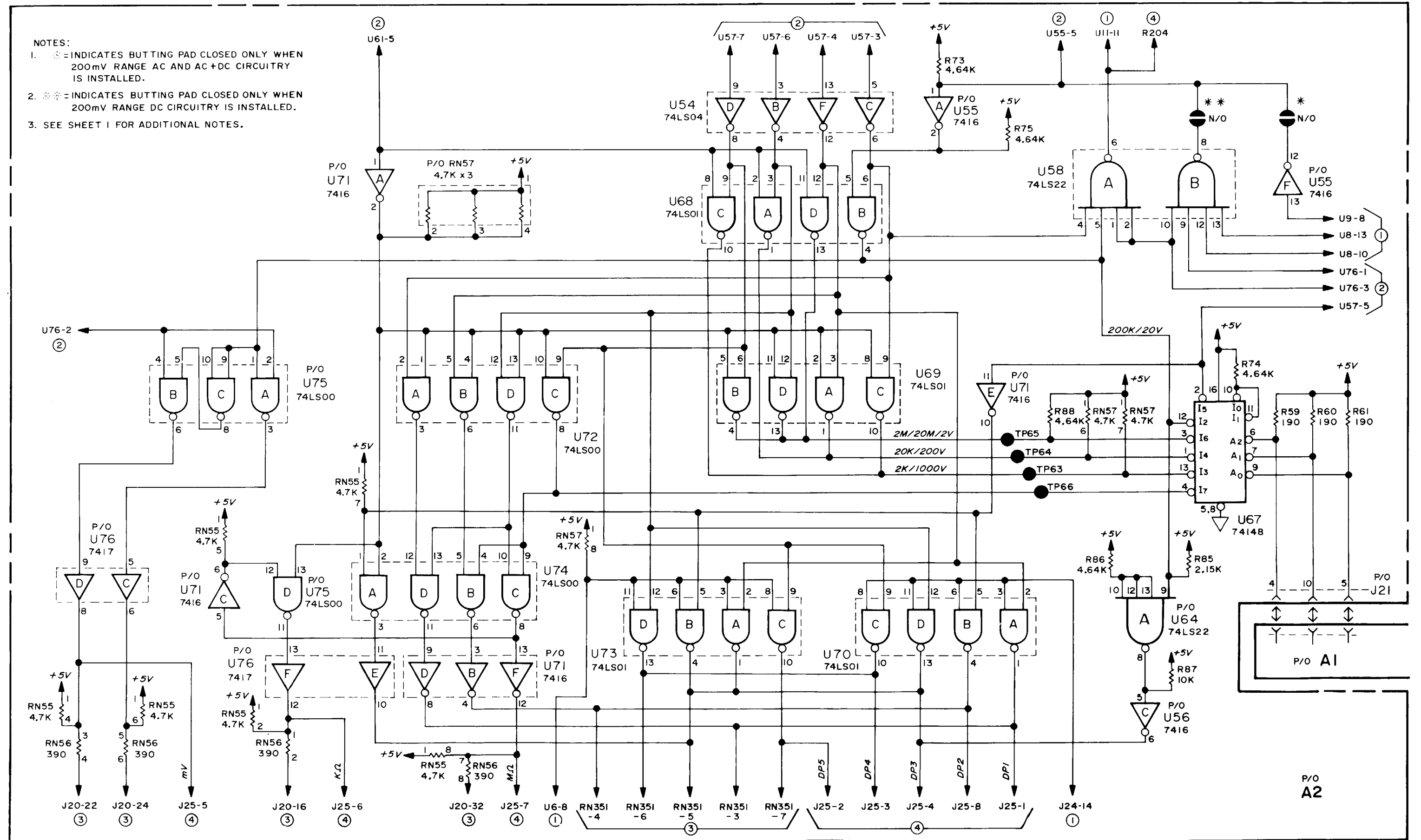
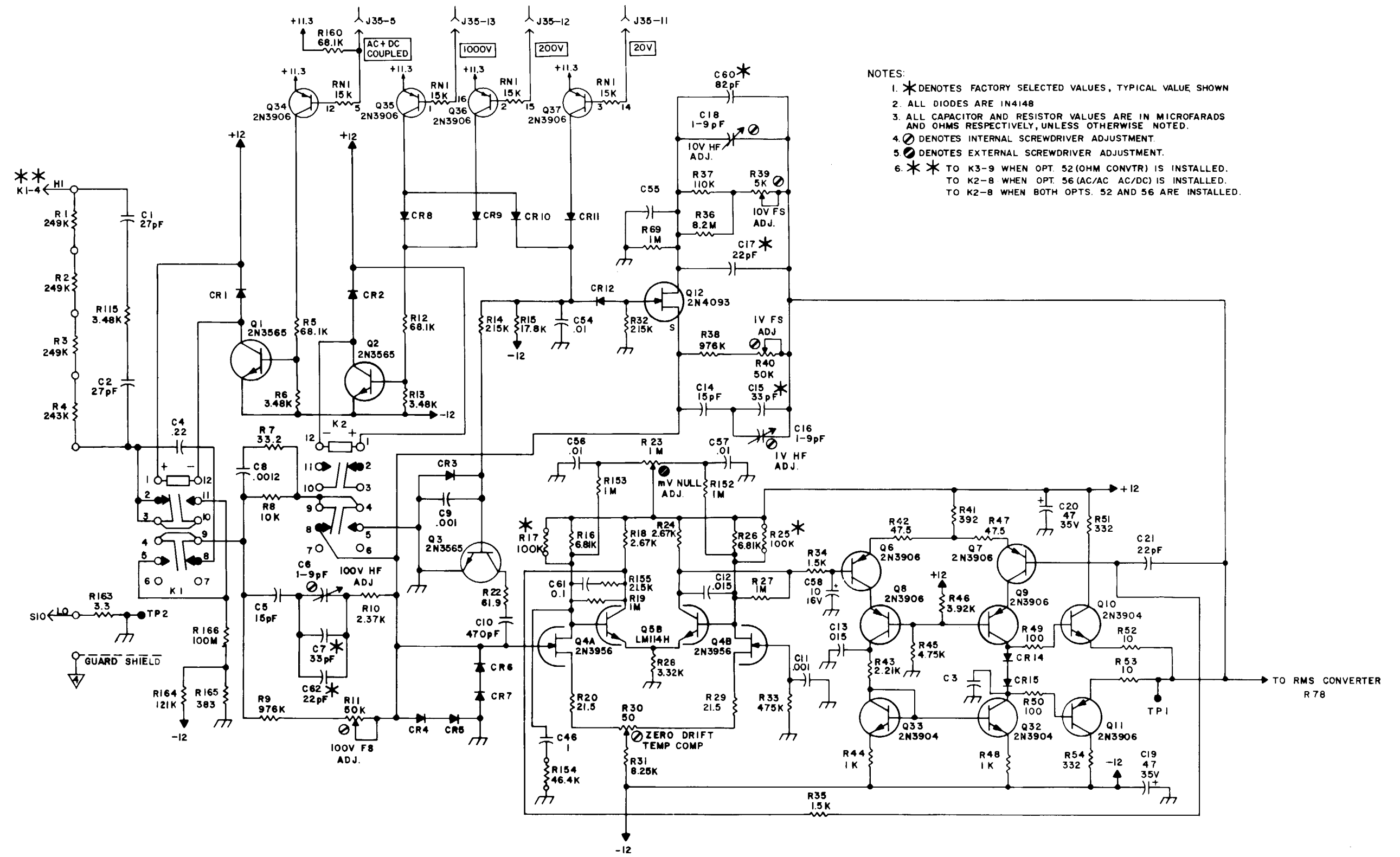

Figure FO-11. Range Encoder/DP Encoder Circuits (A2) Schematic Diagram



- NOTES:
- * DENOTES FACTORY SELECTED VALUES, TYPICAL VALUE SHOWN
 - ALL DIODES ARE 1N4148
 - ALL CAPACITOR AND RESISTOR VALUES ARE IN MICROFARADS AND OHMS RESPECTIVELY, UNLESS OTHERWISE NOTED.
 - ⊗ DENOTES INTERNAL SCREWDRIVER ADJUSTMENT.
 - ⊙ DENOTES EXTERNAL SCREWDRIVER ADJUSTMENT.
 - * * TO K3-9 WHEN OPT. 52(OHM CONVTR) IS INSTALLED.
TO K2-8 WHEN OPT. 56(AC/AC AC/DC) IS INSTALLED.
TO K2-8 WHEN BOTH OPTS. 52 AND 56 ARE INSTALLED.

Figure FO-12. Rms Converter Preamplifier and Scaling (A7) Schematic Diagram

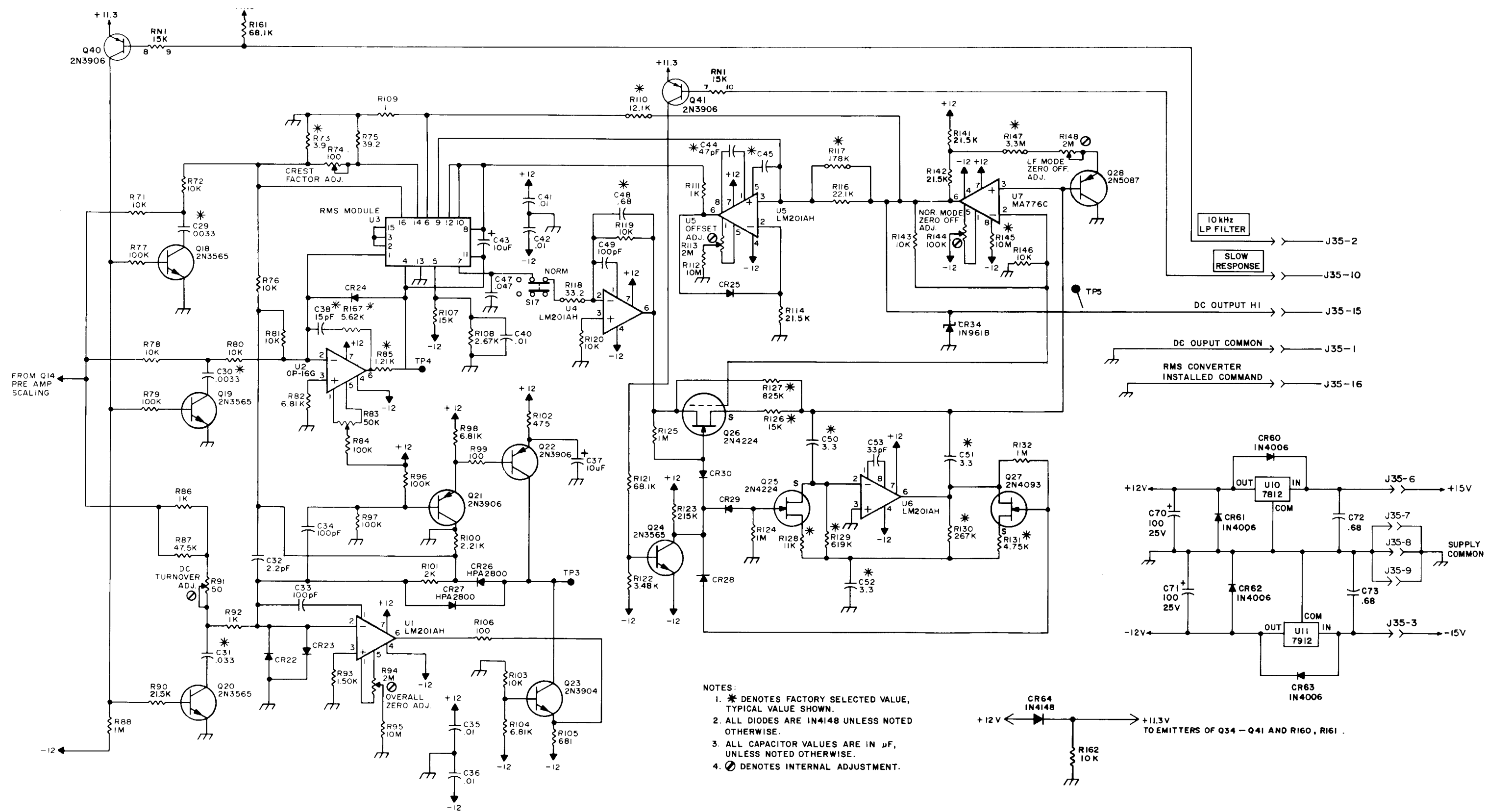
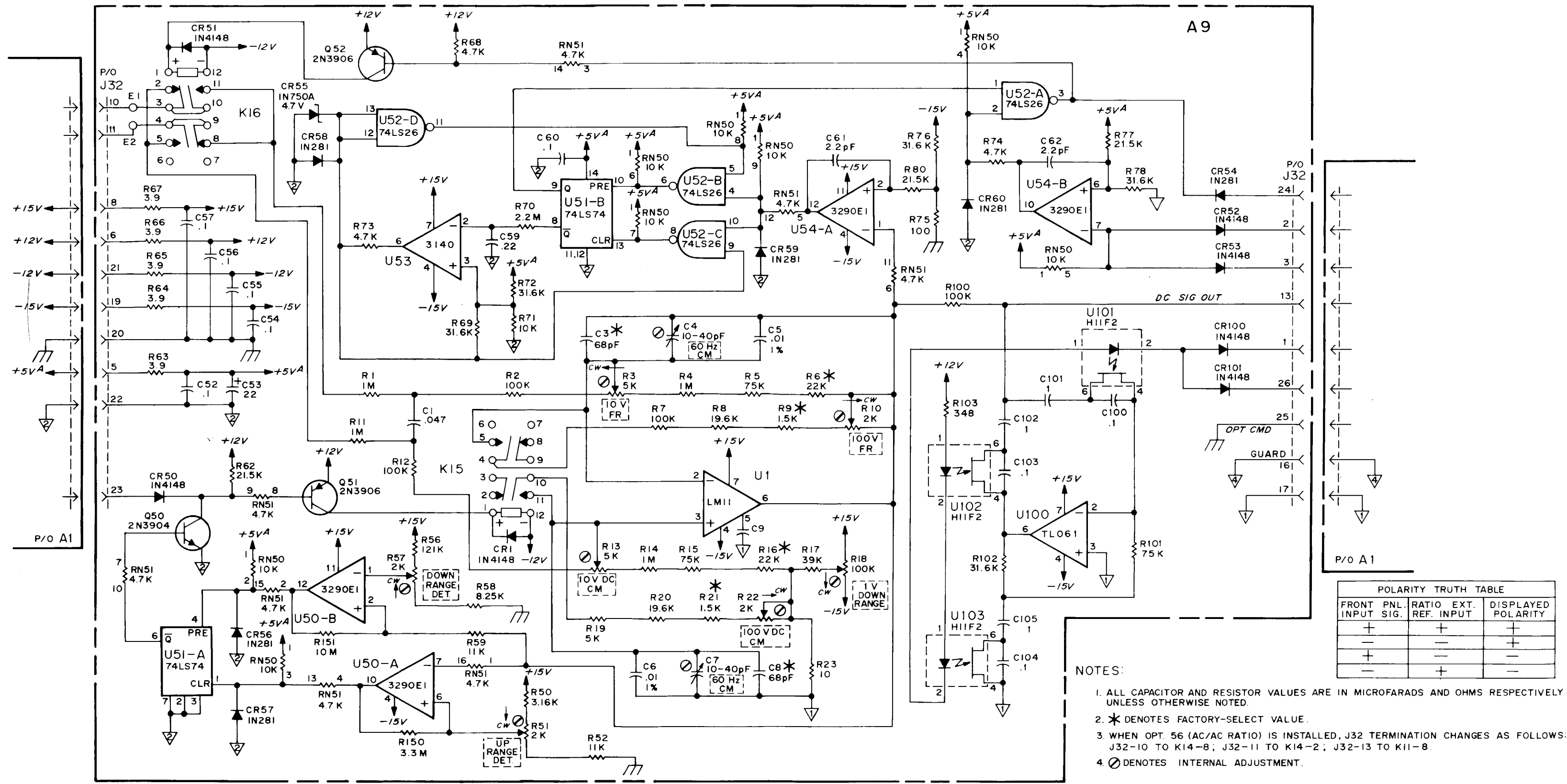

Figure FO-13. True Rms Converter (A7) Schematic Diagram



EL6U2042

Figure FO-14. Dc Ratio Amplifier (A9) Schematic Diagram

By Order of the Secretary of the Army:

E. C. MEYER
General, United States Army
Chief of Staff

Official:

ROBERT M. JOYCE
Major General United States Army
The Adjutant General

DISTRIBUTION:

To be distributed in accordance with Special List.

*U.S. GOVERNMENT PRINTING OFFICE: 1993-342-421/61869

These are the instructions for sending an electronic 2028

The following format must be used if submitting an electronic 2028. The subject line must be exactly the same and all fields must be included; however only the following fields are mandatory: 1, 3, 4, 5, 6, 7, 8, 9, 10, 13, 15, 16, 17, and 27.

From: "Whomever" <whomever@wherever.army.mil>

To: 2028@redstone.army.mil

Subject: DA Form 2028

1. **From:** Joe Smith
2. **Unit:** home
3. **Address:** 4300 Park
4. **City:** Hometown
5. **St:** MO
6. **Zip:** 77777
7. **Date Sent:** 19-OCT-93
8. **Pub no:** 55-2840-229-23
9. **Pub Title:** TM
10. **Publication Date:** 04-JUL-85
11. **Change Number:** 7
12. **Submitter Rank:** MSG
13. **Submitter FName:** Joe
14. **Submitter MName:** T
15. **Submitter LName:** Smith
16. **Submitter Phone:** 123-123-1234
17. **Problem:** 1
18. **Page:** 2
19. **Paragraph:** 3
20. **Line:** 4
21. **NSN:** 5
22. **Reference:** 6
23. **Figure:** 7
24. **Table:** 8
25. **Item:** 9
26. **Total:** 123
27. **Text:**

This is the text for the problem below line 27.

RECOMMENDED CHANGES TO PUBLICATIONS AND BLANK FORMS For use of this form, see AR 25-30; the proponent agency is ODISC4.						Use Part II (reverse) for Repair Parts and Special Tool Lists (RPSTL) and Supply Catalogs/Supply Manuals (SC/SM)	DATE 8/30/02
TO: (Forward to proponent of publication or form)(Include ZIP Code) Commander, U.S. Army Aviation and Missile Command ATTN: AMSAM-MMC-MA-NP Redstone Arsenal, 35898						FROM: (Activity and location)(Include ZIP Code) MSG, Jane Q. Doe 1234 Any Street Nowhere Town, AL 34565	
PART 1 - ALL PUBLICATIONS (EXCEPT RPSTL AND SC/SM) AND BLANK FORMS							
PUBLICATION/FORM NUMBER TM 9-1005-433-24						DATE 16 Sep 2002	TITLE Organizational, Direct Support, And General Support Maintenance Manual for Machine Gun, .50 Caliber M3P and M3P Machine Gun Electrical Test Set Used On Avenger Air Defense Weapon System
ITEM NO.	PAGE NO.	PARA-GRAPH	LINE NO. *	FIGURE NO.	TABLE NO.	RECOMMENDED CHANGES AND REASON	
1	WP0005 PG 3		2			Test or Corrective Action column should identify a different WP number.	
EXAMPLE							
<i>* Reference to line numbers within the paragraph or subparagraph.</i>							
TYPED NAME, GRADE OR TITLE MSG, Jane Q. Doe, SFC						TELEPHONE EXCHANGE/ AUTOVON, PLUS EXTENSION 788-1234	SIGNATURE

TO: (Forward direct to addressee listed in publication) Commander, U.S. Army Aviation and Missile Command ATTN: AMSAM-MMC-MA-NP Redstone Arsenal, 35898	FROM: (Activity and location) (Include ZIP Code) MSG, Jane Q. Doe 1234 Any Street Nowhere Town, AL 34565	DATE 8/30/02
---	--	------------------------

PART II - REPAIR PARTS AND SPECIAL TOOL LISTS AND SUPPLY CATALOGS/SUPPLY MANUALS

PUBLICATION NUMBER			DATE	TITLE				
PAGE NO.	COLM NO.	LINE NO.	NATIONAL STOCK NUMBER	REFERENCE NO.	FIGURE NO.	ITEM NO.	TOTAL NO. OF MAJOR ITEMS SUPPORTED	RECOMMENDED ACTION

PART III - REMARKS (Any general remarks, corrections, or suggestions for improvement of publications and blank forms. Additional blank sheets may be used if more space is needed.)

EXAMPLE

TYPED NAME, GRADE OR TITLE MSG, Jane Q. Doe, SFC	TELEPHONE EXCHANGE/AUTOVON, PLUS EXTENSION 788-1234	SIGNATURE
---	--	-----------

RECOMMENDED CHANGES TO PUBLICATIONS AND BLANK FORMS <small>For use of this form, see AR 25-30; the proponent agency is ODISC4.</small>						Use Part II (reverse) for Repair Parts and Special Tool Lists (RPSTL) and Supply Catalogs/Supply Manuals (SC/SM)	DATE
TO: (Forward to proponent of publication or form)(Include ZIP Code) Commander, U.S. Army Aviation and Missile Command ATTN: AMSAM-MMC-MA-NP Redstone Arsenal, AL 35898						FROM: (Activity and location)(Include ZIP Code)	
PART 1 - ALL PUBLICATIONS (EXCEPT RPSTL AND SC/SM) AND BLANK FORMS							
PUBLICATION/FORM NUMBER						DATE	TITLE
ITEM NO.	PAGE NO.	PARA-GRAPH	LINE NO. *	FIGURE NO.	TABLE NO.	RECOMMENDED CHANGES AND REASON	
<i>* Reference to line numbers within the paragraph or subparagraph.</i>							
TYPED NAME, GRADE OR TITLE						TELEPHONE EXCHANGE/ AUTOVON, PLUS EXTENSION	SIGNATURE

TO: (Forward direct to addressee listed in publication) Commander, U.S. Army Aviation and Missile Command ATTN: AMSAM-MMC-MA-NP Redstone Arsenal, AL 35898	FROM: (Activity and location) (Include ZIP Code)	DATE
--	---	-------------

PART II - REPAIR PARTS AND SPECIAL TOOL LISTS AND SUPPLY CATALOGS/SUPPLY MANUALS

PUBLICATION NUMBER			DATE	TITLE				
PAGE NO.	COLM NO.	LINE NO.	NATIONAL STOCK NUMBER	REFERENCE NO.	FIGURE NO.	ITEM NO.	TOTAL NO. OF MAJOR ITEMS SUPPORTED	RECOMMENDED ACTION

PART III - REMARKS (Any general remarks or recommendations, or suggestions for improvement of publications and blank forms. Additional blank sheets may be used if more space is needed.)

--

TYPED NAME, GRADE OR TITLE	TELEPHONE EXCHANGE/AUTOVON, PLUS EXTENSION	SIGNATURE
----------------------------	--	-----------

